

HYGROUND[®] Compression Grounding Solutions



Connecting Power to Your World[®]





BURNDY® HYGROUND®

Looking for a safe, cost-effective and time-efficient grounding method? The HYGROUND® irreversible compression grounding system is a complete system of connectors for cross-grid connections, taps, splices, cable to ground rod, ground plates and terminations. Acceptable for direct burial in earth and concrete, HYGROUND® is UL 467 and UL 96 Listed, CSA Certified, and IEEE 837 qualified.

System Features and Benefits

- A range-taking tool and die design minimizes inventory and provides for multiple connector combinations.
- Pre-crimp dies for ground rod connectors add mechanical strength to help the connectors withstand power installation and maintain IEEE and UL performance.
- All compression elements are made of pure wrought copper—the same material as the conductor.
- The heavy-duty connector design carries the equivalent or greater current-carrying capacity of the conductor.
- All compression elements are strip sealed to keep contact surfaces clean.
- Most compression elements are pre-filled with our exclusive PENETROX™ compound to inhibit moisture and contaminants.
- Installation is easy, and requires no special training or complicated tooling.
- Each connection can be made in less than three minutes.
- Compression connections can be installed in all kinds of weather for better job scheduling.
- The installation process does not produce heat, smoke or fumes.
- Drilling, tapping or welding is not required for connections to most structural steel, which ensures safe installation and leads to lower labor costs.
- Each connector is clearly marked for easy and accurate identification.
- Inspection ports are provided in terminal and splice connectors to ensure the proper insertion of the conductor for increased quality assurance.
- Crimping embosses the die index number on the connector, confirming consistent connections and providing for easy inspectability.
- Suitable for use on Copperweld™ or copper clad cable.
- Tin plated connectors available.

“The HYGROUND® system provides some real valuable, intangible benefits that are difficult to evaluate monetarily. Benefits include installation ease, no cleanup, no burn hazards and no weather concerns. And HYGROUND® results in a very consistent, quality connection.”

– David Lucke, BSC Engineered Systems, Spokane, WA

Application/Users

If you would like to contact BURNDY® HYGROUND® users in the fields highlighted here, please call our Marketing Department at 1-800-346-4175 and we'll put you in touch.

Telecommunications

The wireless industry is a perfect candidate for the BURNDY® HYGROUND® system because it offers the only grounding system that installs quickly and easily, regardless of the weather. "Traditional" phone companies have been HYGROUND® users for many years.

Renewable Energy

As the renewable energy industry has grown, so has our involvement. Today, BURNDY supplies products and services that span the entire scope (turbine, tower, collection system, substation and transmission) of the renewable energy industry. BURNDY® HYGROUND® is a safe, cost-effective and time-efficient grounding method that meets the needs of the renewable energy marketplace.

Architectural and Construction Engineers

Consultant engineering firms—the specifiers—appreciate the benefits of having a sound, proven grounding system that's easy to install. Including BURNDY® HYGROUND® on your standards saves on labor costs and job-site injuries as well as reduces the chance of work delays. The available BURNDY® DXF/DWG files are importable into various AutoCad™ revisions for easy drafting, drawing and specification writing.

Army Corps of Engineers

While the Army Corps of Engineers has not adopted one central standard for below-grade grounding, BURNDY® HYGROUND® has been included in several major projects of the armed forces, and is approved for use by the Federal Aviation Administration (FAA) and the Occupational Safety and Health Administration (OSHA).

Petrochem

Petrochem customers find the HYGROUND® system to be the safest, most consistent and best labor-savings option for petrochemical site construction and maintenance. Since HYGROUND® is installed with hydraulic tooling, the need for special permits and other special precautions is greatly reduced.

Utilities/Rural Utility Services (RUS)

The utility industry is especially susceptible to fault currents. Rural Utility Services (RUS) represents more than 1,000 rural electric systems that own and maintain nearly half of the nation's poles and power lines, and many are protected by BURNDY® HYGROUND®. BURNDY® HYGROUND® connectors meet or exceed all industry specifications for system standards and performance, including RUS listing for its YGL HYGRID™ cross-grid connector.

Distributors

By stocking relatively few BURNDY® HYGROUND® connectors, a distributor can easily service the majority of end-user requirements. The Customer Service and Sales Departments at BURNDY are well regarded within the industry.



BURNDY® HYGROUND® Compression Connector Grid

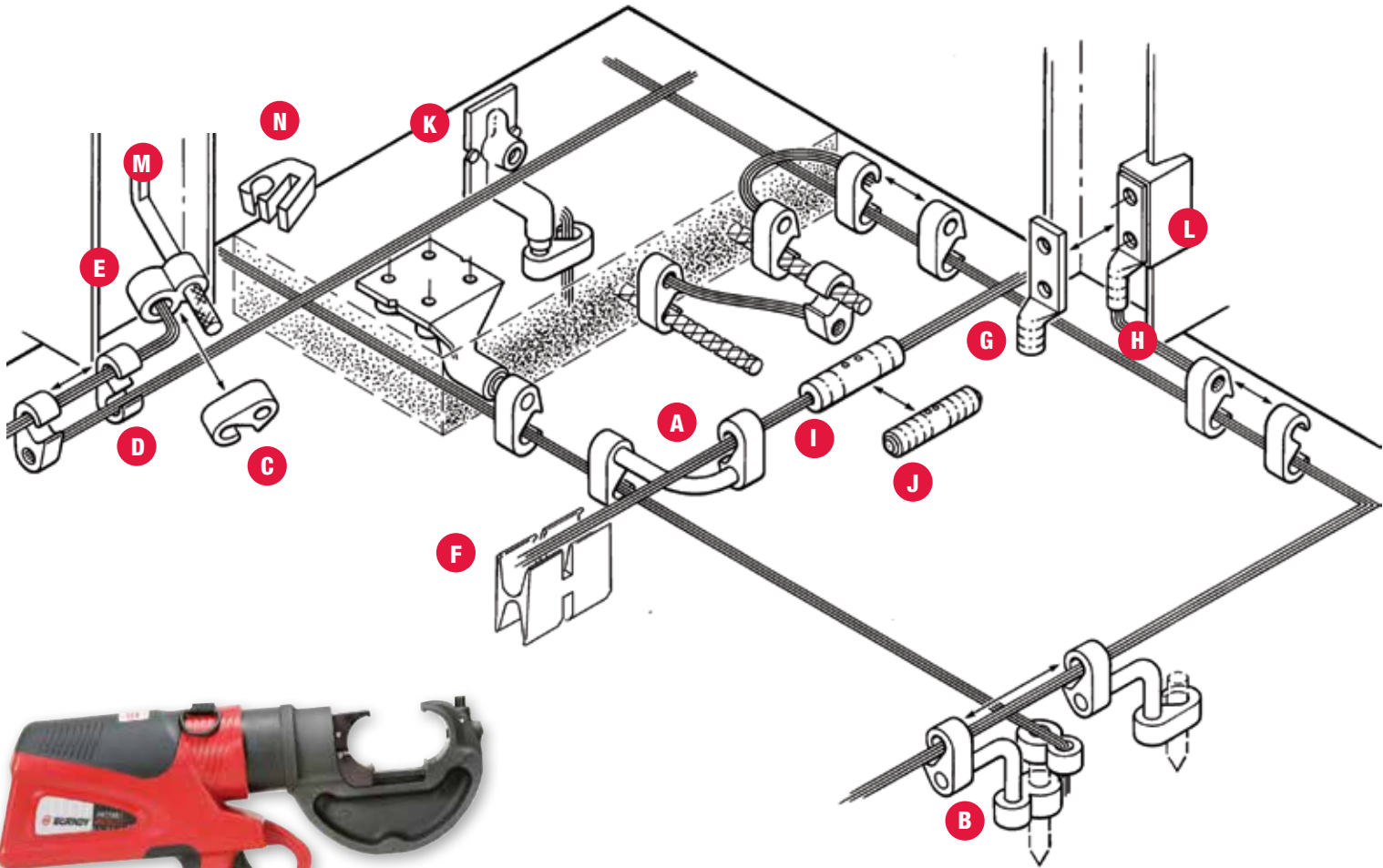

Safe and Easy to Install

- **BURNDY® HYGROUND® is the safest, most cost-effective, time-efficient and easily inspected grounding system available today.** A BURNDY® HYGROUND® compression connection can be made in three minutes.
- **The efficiency and consistency of installing a BURNDY® HYGROUND® compression grid translates to tremendous labor savings.**
- **BURNDY® HYGROUND® helps you keep your entire jobsite on schedule.** Compression connections can be made in even the most inclement weather conditions—rain, wind or snow.

Components

A Hygrid™ Cross Connector (YGL-C)

- Designed for cross connections as well as “ells” and “tees”
- Rotating elements facilitate positioning prior to crimp
- Conductor range #6 through 500 kcmil
- IEEE837



B Gridlok™ Ground Rod to Grid Connector (YGLR-C)

- Provides high-torque connection to ground rod
- Rotating elements facilitate installation
- Conductor range #2 through 500 kcmil
- Ground rod sizes 1/2", 5/8", 3/4", and 1"
- IEEE837



C Figure “6” Hytap™ Connector (YGHP-C)

- Can be used as a tap connector or a lap splice connector
- Conductor range #8 through 500 kcmil
- Ground rod sizes 1/2", 5/8", and 3/4"
- IEEE837



D Figure “C” Hytap™ Connector (YGHC-C)

- Can be used for tap or cross connections
- “C”-shaped opening permits placing two parallel cables into conductor groove
- Conductor range #6 through 500 kcmil
- Wire to ground rod applications
- IEEE837



E Hytail™ Ground Rod Tap Connector (YGHR-C)

- Provides a tap or pigtail-type connection from ground rods to grounding counterpoise or grid
- Conductor range #2 through 500 kcmil
- Ground rod sizes 1/2", 5/8", and 3/4"
- IEEE837



F Double H-Tap Connector (YSHG)

- Conductor range #14 through 500 kcmil
- Ground rod sizes 3/4" and 1"
- Rebar size #6



G Hylug™ Heavy-Duty Terminals (YGHA)

- Designed to carry a short-circuit load and withstand high mechanical stress
- Inspection hole ensures proper cable insertion
- Conductor range #2 through 500 kcmil
- IEEE837



H Hylug™ Terminals (YGA)

- Designed for ground applications
- Inspection hole ensures proper cable insertion
- Standard NEMA hole spacing
- Conductor range #8 through 500 kcmil



I Hylink™ Heavy-Duty Splice (YGHS)

- Designed to carry a short-circuit load and withstand high mechanical stress
- Inspection hole and center stop ensure proper cable insertion
- Conductor range #2 through 500 kcmil
- IEEE837



J Hylink® Splice (YGS)

- Designed to carry a short-circuit load and withstand high mechanical stress
- Inspection hole and center stop ensure proper cable insertion
- Conductor range #2 through 500 kcmil



K Grounding Plate (YGF)

- Withstands the rigors of concrete construction
- Pre-tapped two- or four-hole NEMA spacing
- Tapped hole on underside for ease of repositioning



- Plugged holes keep dirt out
- Conductor range #2 through 500 kcmil
- IEEE837

L GroundLink™ Connector (YGIB)

- Unique design allows for ground attachment to structural steel
- Available for straight or angled steel
- Includes thread protection studs to prevent hole deformation
- IEEE837



M Versitail Structural Steel Connector (GSTUD-HY)

- Welds to steel surfaces quickly with regular equipment
- Eliminates costly disk grinding
- Copper-plated knurled area for excellent gripping and electrical integrity



Static Grounding Receptacle (YGT and YTTAG) *Not Shown*

- Connects to ground grid and finished flush
- YTTAG for aircraft applications



Hytap™ Ground Electrode Tap Connector (YGHP-C) *Not Shown*

- A ground rod connector with an open groove for continuous run and tapping applications (second groove for tap only)
- “Third hand” constrains conductors while installer completes crimp
- IEEE837



N Bus Bar/Flat Steel Connector (YG-B)

- Designed to attach tap conductor(s) to 1/8"-1/4" thick copper bus bar or flat steel.
- Conductor range #6 through 4/0.
- Suitable for 1 or 2 conductors for power or grounding and bonding applications.



Note that all components are suitable for direct burial in earth or concrete.

Please contact customer service for applications requiring IEEE837 2014.



Inspectability

The compression made by the BURNDY® HYGROUND® tool and die combination also embosses an identification code on the installed connector. This mark allows installers and electrical inspectors to visually—and quickly—confirm the proper connector, tool and installation die were used as well as ensure the connector has been correctly placed. Since BURNDY® HYGROUND® compression tools are designed to complete the crimp before releasing, you can be further assured of the installation quality.

- BURNDY® Compression Tools/Pumps
- HYPRESS™ hydraulic tool Y750 series
- HYPRESS™ remote-operated hydraulic tool (Y46)
- PATRIOT® battery-actuated tool PAT750 series
- EPP series electric/hydraulic pump (EPP10) with remote
- Y10AC9 hydraulic pump for use with remote heads (Y46 or Y750 series)



Note the connector identification letters, including conductor ranges and required installation die.



After a compression connection has been made, the embossed and factory-stamped die numbers should match exactly, as noted above. This confirms that the correct die was used to make the grounding connection. The embossed number shows that the output force used to make the compression connection was correct.

“We’re very pleased with BURNDY products, including its crimp tools. Our area representative is knowledgeable about work and field-related situations, and is very helpful and prompt. Our customers are thrilled with HYGROUND® and appreciate that the BURNDY rep is involved.”

– Mark Vargo, Bexar Electric Co., San Antonio, TX

Standards and Codes**NEC® Article 250, Section 250.64**

Grounding Electrode Conductor Installation. *Grounding electrode conductors at the service, at each building or structure where supplied by a feeder(s) or branch circuit(s), or at a separately derived system shall be installed as specified in 250.64(A) through (F).*

System Standards**Federal Government**

- FAA 019B-85 Airport Grounding
- Occupational Safety Hazard Association

Institute of Electrical Electronics Engineers

- IEEE 80-00 Guide for Safety in Substation Grounding (Worldwide)
- IEEE 12-91 Grounding of Industrial and Commercial Power Systems
- IEEE 1100-92 Powering and Grounding Sensitive Electronic Equipment
- T1E1 (U.S., Canada) T1E1-37 Grounding and Bonding of Network Telecommunications Equipment

Performance Standards

- IEEE Standard 837 Standard for Qualifying Permanent Connections Used in Substation Grounding
- UL-467 and CSA C22.2 No. 41 Grounding and Bonding Equipment
- UL-96 Standard for Connectors for Lightning Protection

National Fire Protection Association

- National Electrical Code
- NFPA 780-92 Lightning Protection Code
- NFPA 70E Standard for Electrical Safety Requirements for Employee Workplaces

Underwriters Laboratories

- UL-96A Installation Requirements for LP Systems

Please contact customer service for applications requiring IEEE837 2014.

www.burndy.com | 1-800-346-4175

Customer Service Department

7 Aviation Park Drive
Londonderry, NH 03053
1-800-346-4175
1-603-647-5299 (International)

Canada

1-800-361-6975 (Quebec)
1-800-387-6487 (All other provinces)

Mexico

011-52-722-265-4400

Brazil

011-55-11-5515-7225

Tool Service Center

Littleton Industrial Park
Littleton, NH 03561
1-800-426-8720



Connecting Power to Your World®

