

General Disclaimer

One or more of the Following Statements may affect this Document

- This document has been reproduced from the best copy furnished by the organizational source. It is being released in the interest of making available as much information as possible.
- This document may contain data, which exceeds the sheet parameters. It was furnished in this condition by the organizational source and is the best copy available.
- This document may contain tone-on-tone or color graphs, charts and/or pictures, which have been reproduced in black and white.
- This document is paginated as submitted by the original source.
- Portions of this document are not fully legible due to the historical nature of some of the material. However, it is the best reproduction available from the original submission.



TRW

(NASA-CR-173252) SPACE STATION NEEDS,
ATTRIBUTES AND ARCHITECTURAL OPTIONS STUDY.
FINAL REVIEW EXECUTIVE SUMMARY BRIEFING (TRW
Space Technology Labs.) 136 p HC A07/MF A01

N84-18272

Unclas
CSCL 22B G3/15 00704

**Space Station Needs, Attributes
and Architectural Options Study
Final Review Executive Summary
Briefing**

NASW-3681 April 5, 1983

ORIGINAL PAGE IS
OF POOR QUALITY



TRW

NASA

**Space Station Needs, Attributes
and Architectural Options Study
Final Review Executive Summary
Briefing**

NASW-3681 April 5, 1983

ORIGINAL PAGE 19
OF POOR QUALITY

Introduction and Conclusions

User Needs/Mission Requirements

Architecture/Mission Implementation

Program Costs and Benefits

Summary and Recommendations

Program Management
Division
TRW Space &
Technology Group



PRECEDING PAGE BLANK NOT FILMED

Introduction

~~PAGE~~ 3 INTENTIONALLY BLANK

TRW STUDY APPROACH

TRW's study approach, outlined on the facing page, is straight forward beginning with extensive interaction with potential users to develop a mission model and corresponding time phased requirements, progressing to architectural trade studies, and ending with program cost/benefit analyses for each of the six scenarios considered.

Mission and architectural scenarios were iterated with the cost analyses to maximize benefits while maintaining reasonable peak year funding levels.

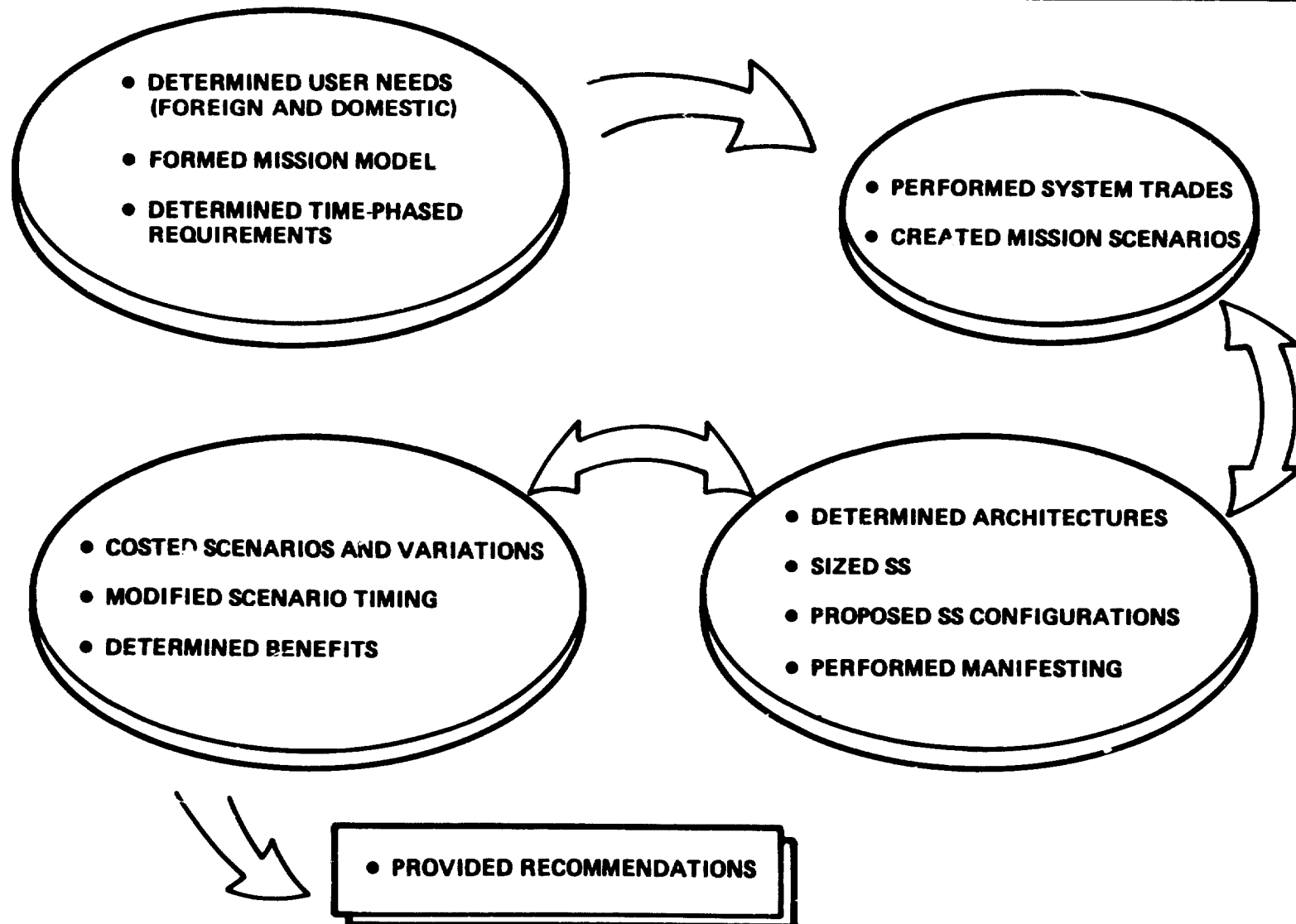

TRW VIEWPOINT THROUGHOUT SPACE STATION STUDY

In the course of this Space Station study, TRW was confronted with numerous issues which could not be answered by the usual technique of defining options and carrying out trade studies. Examples include such questions as including a nuclear power supply, providing artificial gravity for all living and working areas of the SS, and providing for a crew size substantially above Skylab and Shuttle limits. In every case we elected to come down on the side of minimum program cost and risk. Our rationale was that a modest initial space station which has high probability of being deployed on time and for around five billion dollars was by far preferable to a program which could easily experience substantial cost overruns and schedule slips.

TRW's viewpoint further incorporated the concept of including on the early space station those capabilities which support the largest benefits, and accommodate the widest variety of potential users. As will be clear from the rest of this briefing, there were instances where this viewpoint forced hard choices with respect to our minimum cost/risk ideas. However, these principles were employed so frequently that they are worth mentioning at the outset.

AT EVERY SIGNIFICANT DECISION POINT WE CHOSE OPTIONS WHICH:

- MINIMIZE INITIAL PROGRAM RISK
- MINIMIZE INITIAL PROGRAM COST
- MAXIMIZE EARLY BENEFITS
- MAXIMIZE ACCOMMODATION OF USER NEEDS

SPACE STATION STUDY FINAL REPORT CONTENTS

This viewgraph lists the various volumes contained in our final Space Station study report. The NASA documents are all unclassified and consist of this Executive Summary briefing volume, five volumes developed for the detailed working group meetings and a set of five appendices. The working group volumes contain data which could not be presented in this Executive Summary either because of time limitations or by virtue of its proprietary nature. The appendices are documents which were developed in the course of the study and which were significant in developing the positions presented in the other volumes.

The DoD volumes are both classified Top Secret and have therefore been handled according to the security guidelines which form a part of this contract. No classified information will be discussed or presented in any of the NASA briefings.

Taken together, the thirteen documents listed here contain approximately 1,500 pages.

FOR NASA:

- EXECUTIVE SUMMARY BRIEFING VOLUME
- COMMERCIALIZATION WORKING GROUP BRIEFING VOLUME
- MISSION REQUIREMENTS WORKING GROUP BRIEFING VOLUME
- COSTING WORKING GROUP BRIEFING VOLUME
- SYSTEMS WORKING GROUP BRIEFING VOLUME
- TECHNOLOGY WORKING GROUP BRIEFING VOLUME

- APPENDIX A – USER REQUIREMENTS AND BENEFITS CATALOGUE, 18 MARCH 1983
- APPENDIX B – COMMERCIAL-RELATED COMMUNICATION MISSIONS FOR A SPACE STATION, NOVEMBER 1982
- APPENDIX C – MARKETS FOR REMOTE SENSING DATA (1980-2000), 05 NOVEMBER 1982
- APPENDIX D – REPORT OF SURVEY OF SPACECRAFT MANUFACTURERS, 17 DECEMBER 1982
- APPENDIX E – REPORT OF MATERIALS PROCESSING WORKSHOP AT TRW, OCTOBER 1982
- APPENDIX F – COMMERCIAL BUSINESS OPPORTUNITIES, APRIL 7, 1983

FOR DoD:

- DoD FINAL BRIEFING EXECUTIVE SUMMARY, APRIL 1983 – CLASSIFIED
- NATIONAL SECURITY WORKING GROUP BRIEFING VOLUME, APRIL 1983 – CLASSIFIED

PRECEDING PAGE BLANK NOT FILMED

Study Conclusions

PAGE // INTENTIONALLY BLANK

EVOLUTIONARY SPACE STATION SELECTED

As illustrated in the vu-graph we have selected a manned space station which will evolve through three major configurations in the decade of the 1990s. Our study shows that strong arguments exists for this space station to be placed in a 28.5° inclination orbit. The space station is not only intended to grow, but also to be maintained on orbit and to incorporate new technology as it becomes available.

Our studies show further that the wide variety of potential missions and users of a 1990's space station are best accommodated by the presence of free flying unmanned space platforms which can be serviced by the SS in 28.5° orbit or by the STS in polar orbit.

EVOLUTIONARY SPACE STATION SELECTED

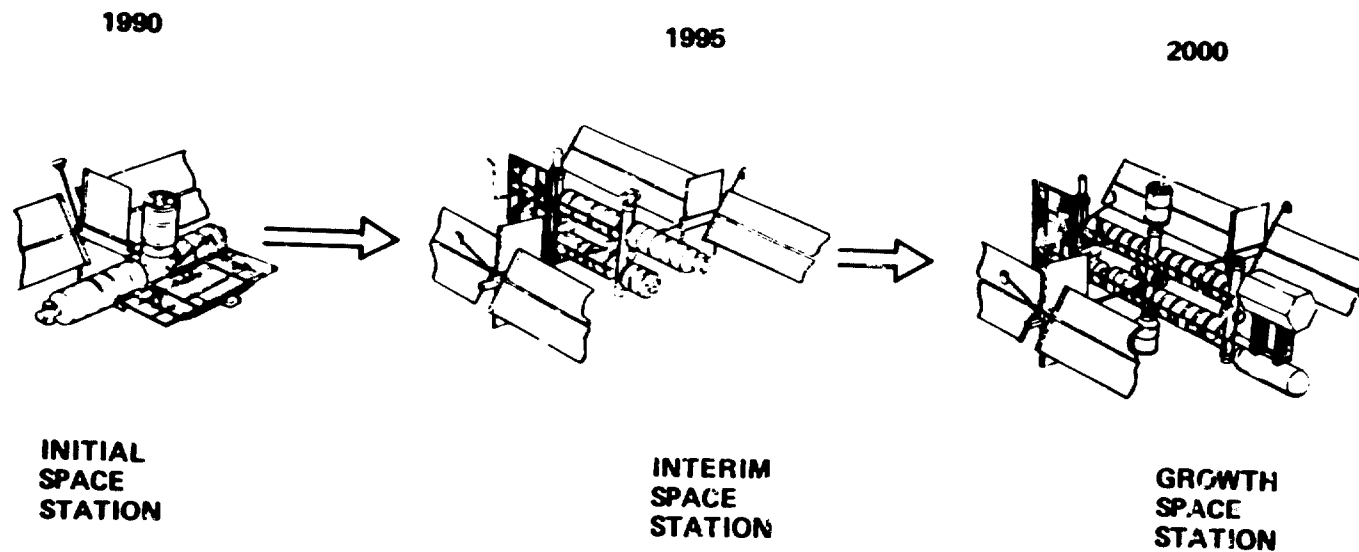

ORIGINAL PAGE 19
OF POOR QUALITY

- INITIAL MANNED SS AT 28.5° INCLINATION BY 1990 RECOMMENDED
- SS AUGMENTED BY SPACE PLATFORMS IN BOTH 28.5° AND POLAR ORBITS

INITIAL SPACE STATION - 1990

Shown is a painting of the space station configuration conceptualized by TRW. This initial space station would be manned by a crew of 5, after having been installed in a 28.5° inclination orbit by four Orbiter flights.

The modular design includes a resource module which supplies utilities, three habitable modules, two airlock modules, a logistics module, a manipulator and an assembly/servicing area. The configuration can grow by the addition of more modules.

The resource module is designed to have high commonality with an unmanned space platform. The solar arrays are sized to deliver 30 kW net power to the payloads and habitable volumes.

INITIAL SPACE STATION (1990)

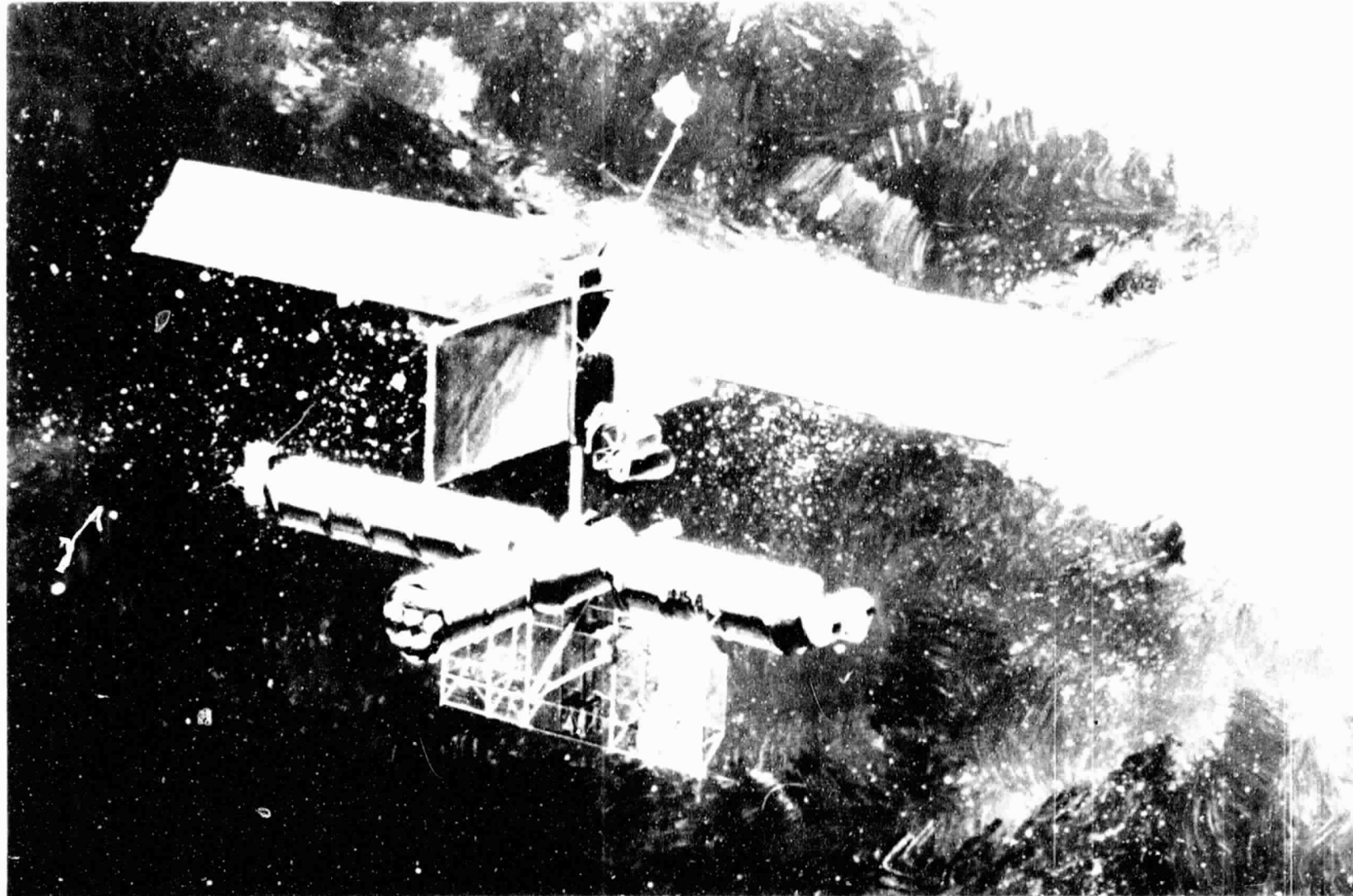

ORIGINAL PAGE IS
OF POOR QUALITY

GROWTH SPACE STATION - 2000

This artist's conception shows the Space Station as it might appear at the end of the century. The Orbiter has just left after one of its periodic re-visits and logistics module exchanges. A teleoperator maneuvering system (TMS) is bringing in a spacecraft for refueling and maintenance.

An Orbital Transfer Vehicle (OTV) is mounted on a carriage on the rail system. A hangar and a cryogenic fuel storage tank are shown at the far end.

This configuration has five habitability modules. It is capable of supporting a crew of from 10 to 12. It would be capable of supporting numerous internal and external payloads.

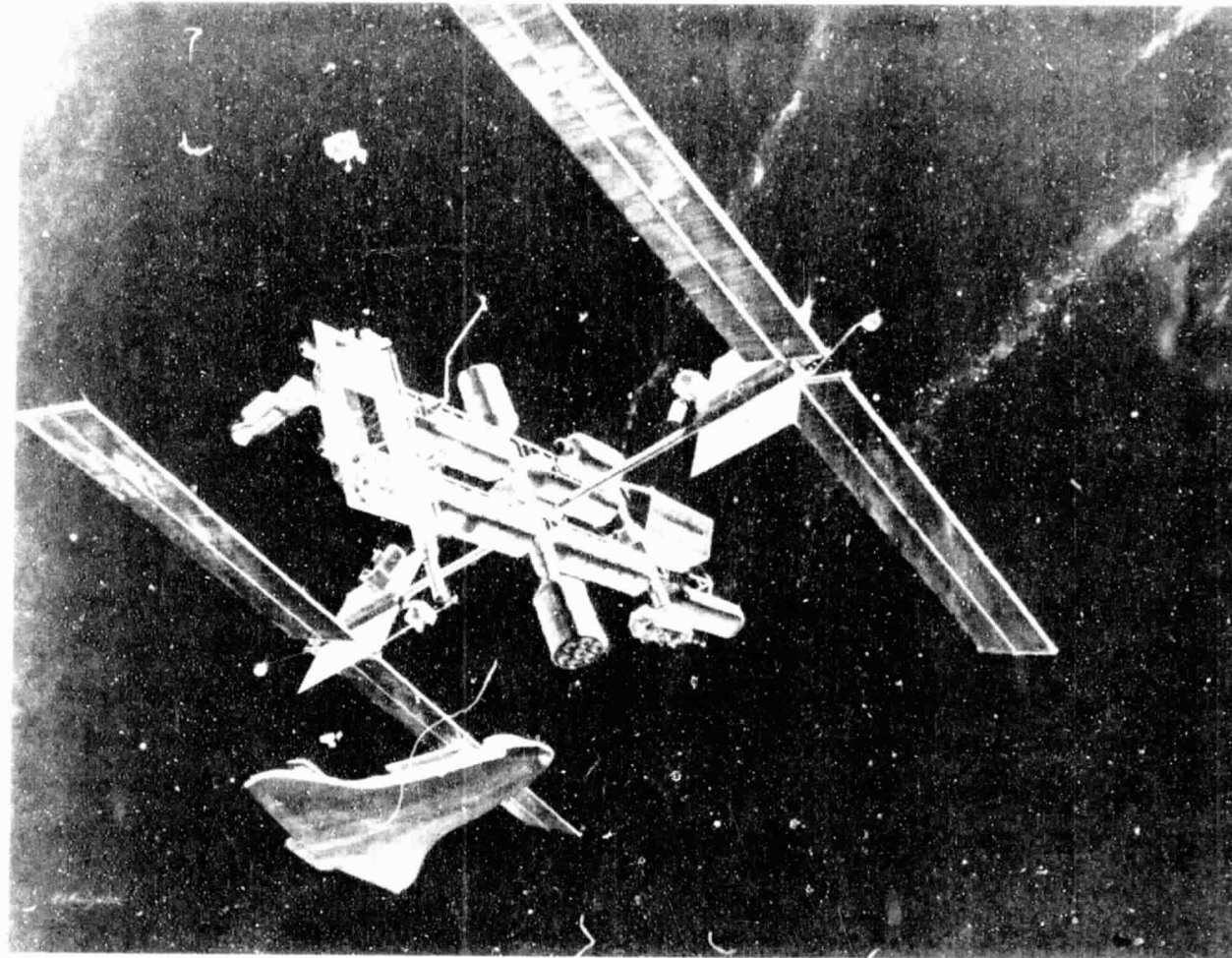

ORIGINAL PAGE IS
OF POOR QUALITY

SPACE STATION ECONOMIC BENEFITS EXCEED COSTS

The space station will be a substantial but profit-making investment for the nation. The initial phase (through 1990) will cost \$5.4 billion. The peak funding in that time period is \$1.3 billion. This investment, along with the subsequent two phases, establishes a benefit stream that peaks at \$2.8 billion in 1997 and establishes net redundant steady state benefits of \$1.8 billion starting in the year 2000. The fact that space station generates Social and Performance benefits only serves to reinforce the value of the investment.

SPACE STATION ECONOMIC BENEFITS EXCEED COSTS



- INITIAL SS COST THROUGH 1990 IS \$5.4B (1984)
- PEAK YEAR FUNDING FOR INITIAL SS IS \$1.3B (1984)
- STEADY STATE NET BENEFITS OF SS EXCEED O&M COSTS BY \$1.8B (1984) PER YEAR BY 2000

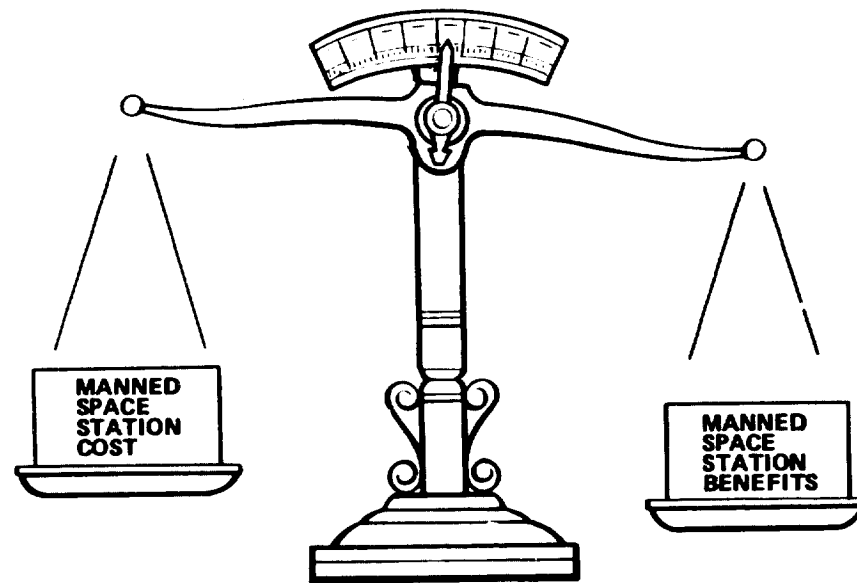

ORIGINAL PAGE 19
OF POOR QUALITY

TRANSPORTATION SAVINGS DOMINATE SS BENEFITS

Our analysis of the economic benefits of a SS lead us to the conclusion that the availability of a manned space station can reduce substantially the cost of space transportation for a given mission model. This result emerges from several findings. First, the STS currently is planned to fly with average load factors of 65% of its maximum capacity. The ability of the SS to act as a warehouse permits the STS load factor to be increased to around 82% by flying spacecraft parts, orbit replacement units (ORUs) and fuel on a space available basis. This modest increment in load factor results in a substantial reduction in the number of STS launches required to support our mission model when a space station is available.

A second finding is that the SS can by virtue of its potential as a base for the operation of a returnable orbital transfer vehicle (ROTV), greatly reduce the cost of deployment flights to geosynchronous earth orbit (GEO) and enable the servicing/repair of GEO satellites. These benefits taken together can amount to over \$10 billion (1984) to 2000.

TRANSPORTATION SAVINGS DOMINATE SS BENEFITS

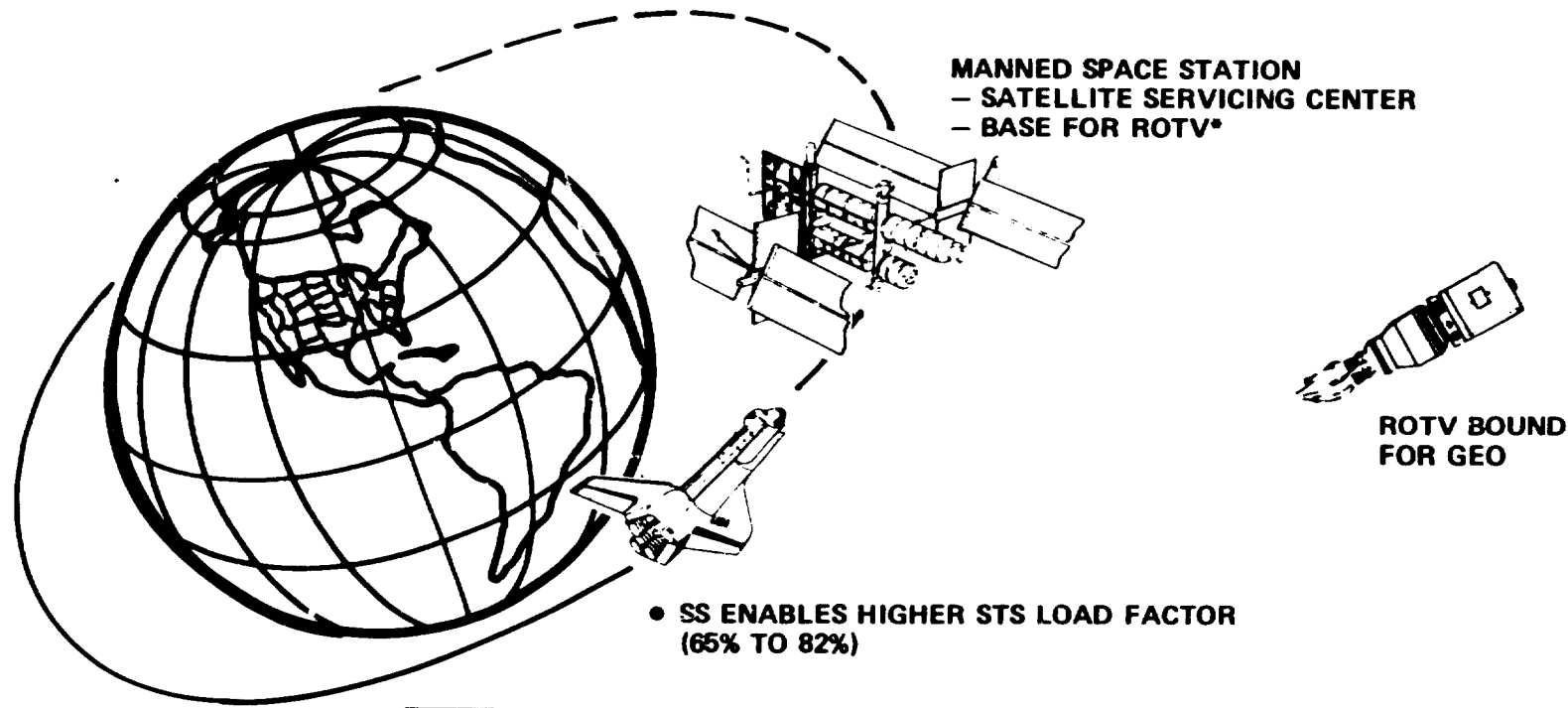

ORIGINAL PAGE 19
OF POOR QUALITY

LARGEST SS BENEFITS DERIVE FROM SERVICING GEO SATELLITES USING A ROTV

* ROTV = RETURNABLE ORBITAL TRANSFER VEHICLE

PRECEDING PAGE BLANK NOT FILMED

Introduction and Conclusions

User Needs/Mission Requirements

Architecture/Mission Implementation

Program Costs and Benefits

Summary and Recommendations



- **User Needs Summary**
- **Space Station Mission Model**
- **Space Station Orbit Options**
- **Phased Mission Requirements**

PAGE 23 INTENTIONALLY BLANK

PRECEDING PAGE BLANK NOT FILMED

User Needs Summary

PAGE 25 INTENTIONALLY BLANK

VALIDATED USER NEEDS & BENEFITS

TRW developed user needs and benefits by using a tailored approach for each user area as summarized below:

- Science - A science panel, comprised of 10 TRW scientists, identified science objectives by reviewing 16 Space Science Board, National Academy of Sciences documents.
- Satellite Servicing - 14 satellites manufacturers were contacted by telephone and subsequently responded to a detailed questionnaire.
- Communications - 23 of 91 commercial communication users contacted responded to our questionnaire. Meetings were held in New York and Los Angeles with respondents.
- Materials Processing in Space - 16 commercial MPS investigators met for 2 days with TRW to determine needs and benefits of a space station.
- Spacecraft On-Orbit Assembly & Test - An analysis was conducted at TRW to determine the economic benefits.
- Space Tourism - 87 travel and hotel executives were requested to respond to a questionnaire - 16 replied.
- Foreign Needs - TRW interacted directly with foreign users in a series of meetings. We met with 3 companies in Japan (IHI, Mitsubishi, Hitachi), 6 in Europe (ERNO/MBB, Aeritalia, Matra, BAE, Dornier) and one in Canada (SPAR).
- Remote Sensing - Direct interviews were conducted with 20 individuals that currently use satellite data for commercial uses.

VALIDATED USER NEEDS & BENEFITS

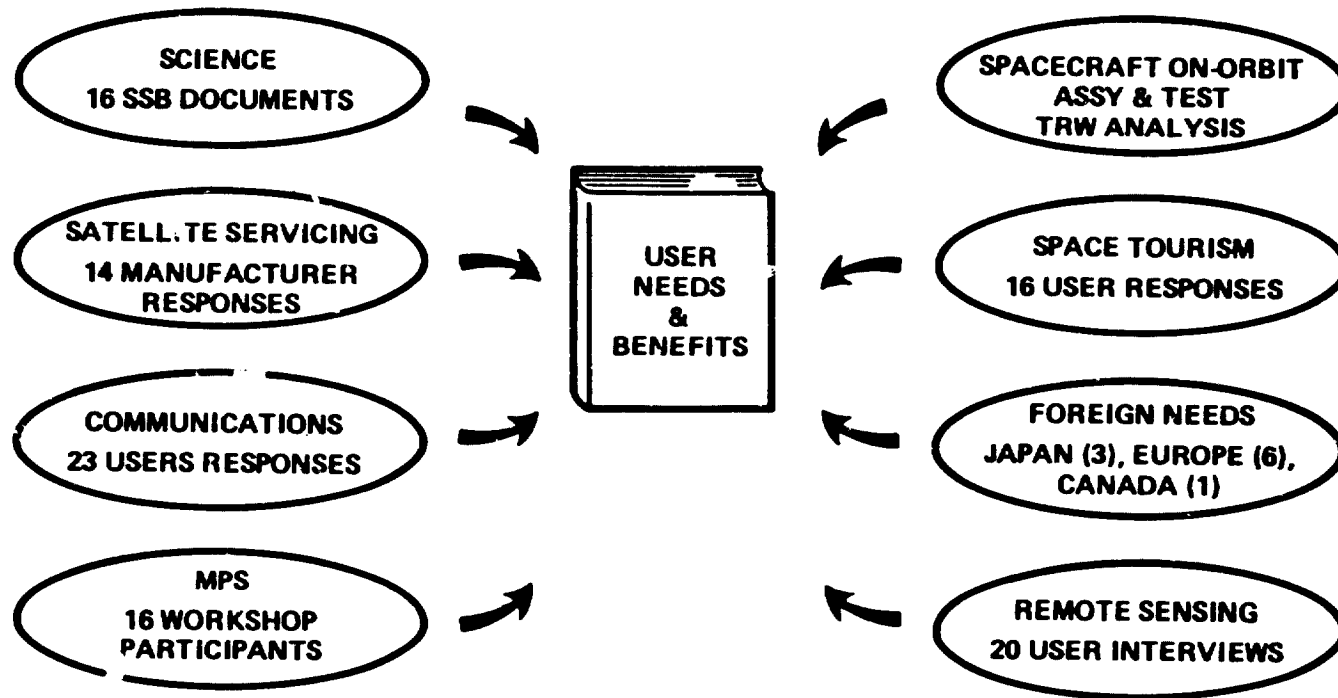

SCIENCE & APPLICATIONS USER NEEDS

The Space Station offers a number of unique capabilities to science and application missions beyond those of the STS. Three are shown on the facing page.

1. The Space Station is a stepping stone to future more far-reaching Space programs. A high priority science mission is the Mars surface sample return mission. Another is a similar mission to an asteroid. The Space Station can enable these missions to be carried out at much less cost than would otherwise be required. For these missions, the Space Station would be used as a staging point to perform final assembly and deployment and would also provide capture and quarantine functions on the return trip.
2. Complex space systems, such as the AXAF, can be serviced by the Space Station rather than returning them to earth.
3. The manned laboratory for life science and materials research provides time on-orbit that is severely limited by the STS. Life science research requires extended time. Materials processing is limited severely with STS. By having a permanent manned laboratory facility, the need to re-launch the Spacelab is eliminated, thus, reducing significant launch costs (about two STS Spacelab launches/year).

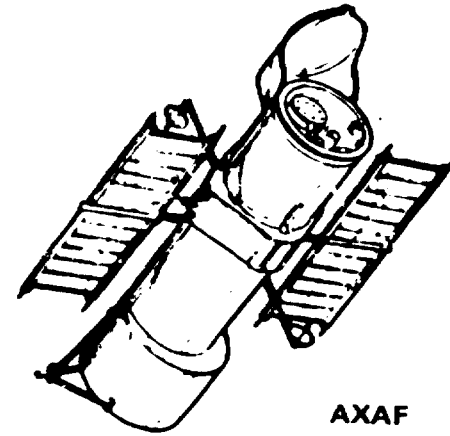
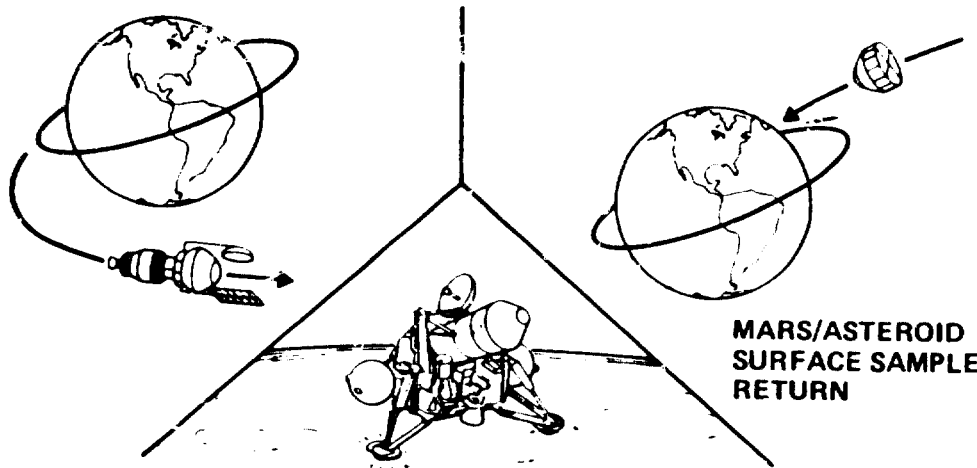

ORIGINAL PAGE IS
OF POOR QUALITY

● BASECAMP TO FUTURE MISSIONS

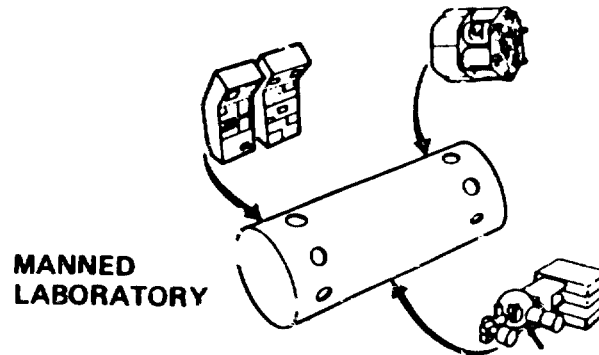

● LIFE SCIENCE AND
MATERIALS RESEARCH

● SERVICE FREE FLYING
CO-ORBITING SPACECRAFT

SCIENCE & APPLICATIONS USER NEEDS (CONTINUED)

Large facilities in space will require man to perform time-consuming assembly operations - beyond the limited STS 9-day staytime. An example of such a system is the Large Deployable Reflector.

Space Platforms, in conjunction with the Space Station servicing, can provide low cost accommodations for multi-instrument observations such as the Solar Terrestrial Observatory. Other examples are the Cosmic Ray Observatory and X-Ray Observatory. The Space Platform design can be simplified and is less costly due to readily available Space Station tending.

TRW reviewed 16 Space Science Board Strategy documents to assess the applicability of science objectives to the space station. Forty-one out of the 75 science missions identified will benefit from a Space Station.

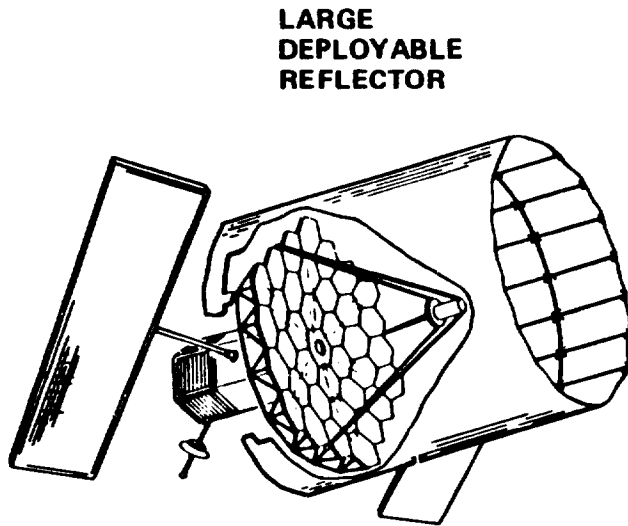

**LARGE
DEPLOYABLE
REFLECTOR**

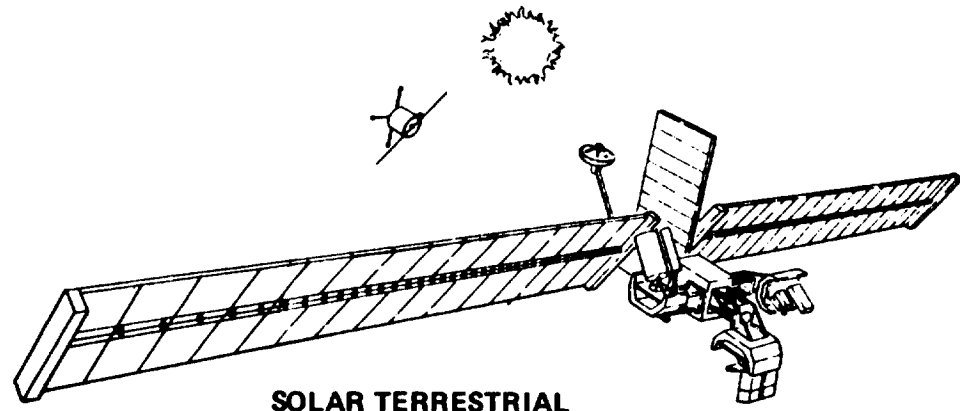

**SOLAR TERRESTRIAL
OBSERVATORY**

- **SPACE ASSEMBLY & CONSTRUCTION
OF LARGE FACILITIES**

- **LOWER COST PLATFORM
ACCOMODATIONS**

**41 OF 75 SCIENCE MISSIONS WILL BENEFIT
FROM A MANNED SPACE STATION**

**ORIGINAL PAGE 19
OF POOR QUALITY**

COMMERCIAL COMMUNICATIONS USER NEEDS

The Space Station offers the opportunity to assemble and test very large communication antennas prior to commitment to geosynchronous orbit. These antennas are difficult to test on earth due to the light structural design. An example of such a large antenna is the large mobile communication satellite antenna. Early versions of such an antenna are being studied for deployment from Shuttle but ultimately requirements will outgrow the limited capability of the STS.

The Space Station will offer lower launch costs to communication satellite users by "barging" (launching multiple satellites on the same launch vehicle) and the use of returnable orbital transfer vehicles (ROTV's) based on the station. In addition, with ROTV's, significant cost benefits accrue due to the capability to lengthen satellite lifetimes via geosynchronous satellite servicing.

COMMERCIAL COMMUNICATIONS USER NEEDS

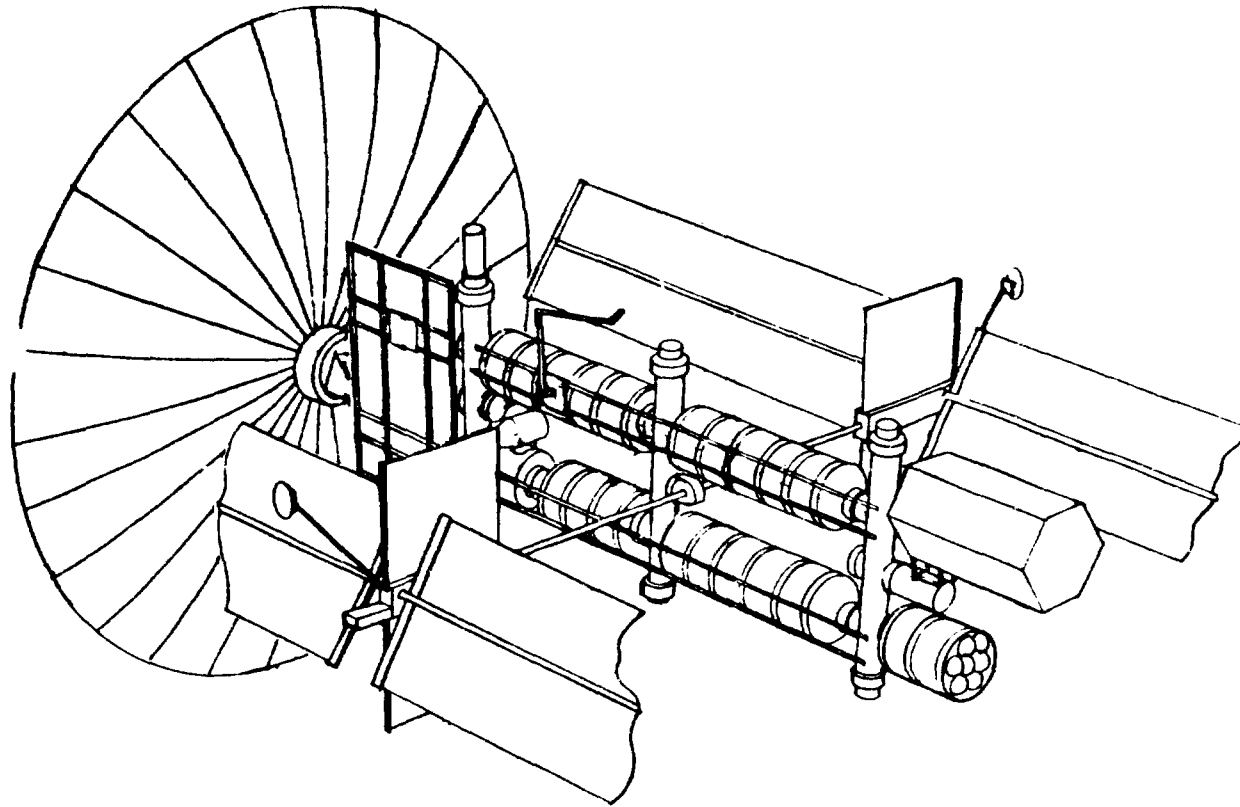

ORIGINAL PAGE IS
OF POOR QUALITY

- LARGE ANTENNA TESTING AND LARGE SYSTEM ASSEMBLY AND TEST
- REDUCED TRANSPORTATION COST TO GEO
- EXTENDED GEO SATELLITE LIFE



COMMERCIAL MPS USER NEEDS

TRW's workshop on Space Station Materials Processing in Space (MPS) was attended by 16 representatives from companies likely to become users of an MPS capability. All of the participants have been involved in MPS research. They indicated that it is too early to predict an MPS market but believe a Space Station is desirable to enable on-going research. Currently, MPS research is limited to Shuttle short duration flights with Spacelab, available about two flights/year only. With a permanent manned laboratory available on the Space Station the need to relaunch the research facility each time data is sought is avoided. Even with a Space Station, workshop participants indicate that five years of research and development is needed to identify a profitable product.

Once the research phase is completed, materials production will be accomplished on a free-flying facility tended by the Space Station.

Thus far the most promising MPS product lines appear to be biochemicals and microelectronic materials. MPS research, however, is just beginning.

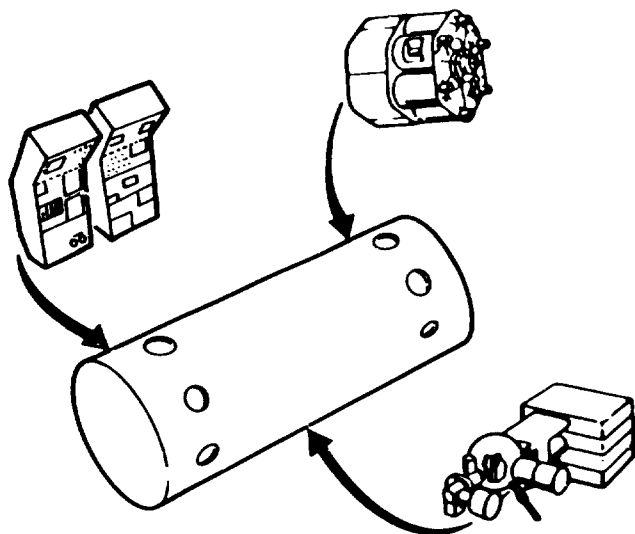

● **INDUSTRIAL MATERIALS RESEARCH
MANNED LABORATORY**

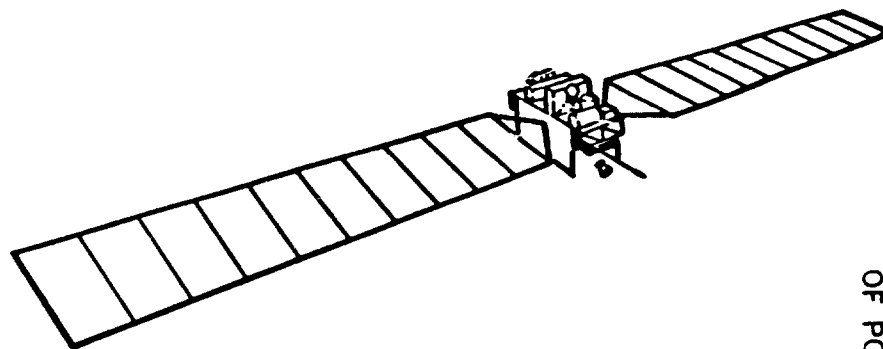

● **AUTOMATED MATERIALS
PROCESSING FACTORY**

**ORIGINAL PAGE IS
OF POOR QUALITY**



COMMERCIAL REMOTE SENSING USER NEEDS

With the help of 2 subcontractors (Terra-Mar Associates and Al Loomis Associates), TRW analyzed the commercial market potential for remote sensing. A great deal of user enthusiasm was encountered. The facing page shows some of the needs identified. We believe that a significant market exists now for space remote sensing data and as the value added industry develops, the willingness of the private sector to invest in space resources (instrument and spacecraft) will significantly increase. Current government deliberations concerning commercialization of USA remote sensing space assets could significantly affect the realization of a commercial remote sensing industry. Foreign efforts to develop this market are also a factor.



- **OCEAN WIND/WAVE FORECASTING FOR OCEAN INDUSTRIES**



- **SEA ICE FORECASTING**

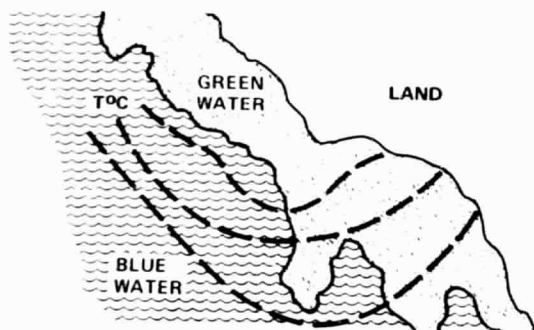

- **OCEAN MONITORING FOR FISHERIES MANAGEMENT**



- **CROP CONDITION ASSESSMENT AND MINERAL RESOURCE DISCOVERY**

ORIGINAL PAGE IS
OF POOR QUALITY

PRECEDING PAGE BLANK NOT FILMED

Space Station Mission Model

MISSION IMPLEMENTATION CATEGORIES

TRW analyzed each mission to determine which facility implementation is appropriate for that mission based on the discriminators shown on the facing page. Our analysis shows that all 4 implementations are needed during the 1990 to 2000 period. The Space Station is obviously necessary for the latter 2 implementations but also is shown (in our final study briefings) to return significant economics benefits by servicing/tending free-flying spacecraft and space platforms.

MISSION IMPLEMENTATION CATEGORIES

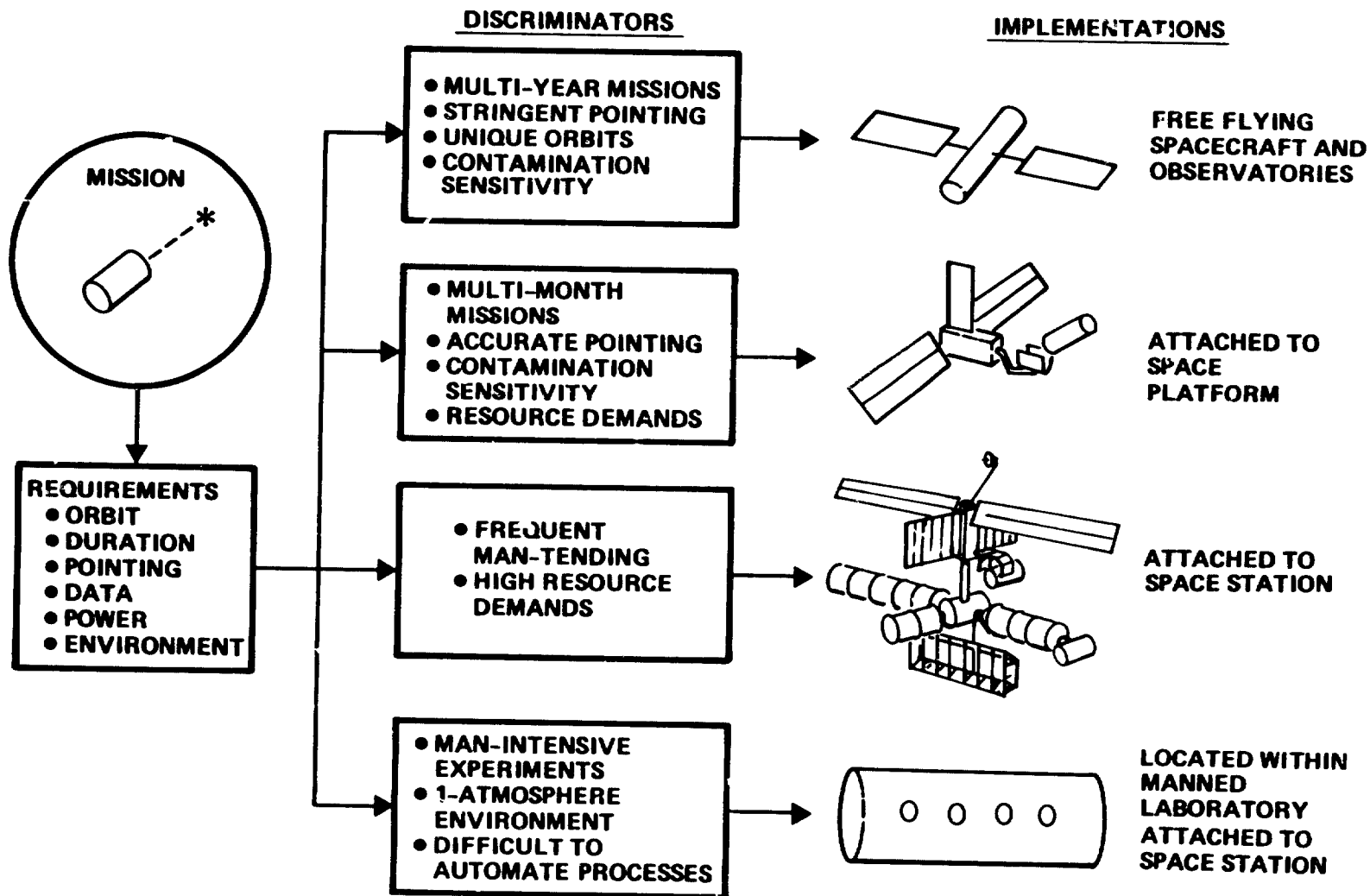

MISSION MODEL STRUCTURE

The mission model has been structured to divide missions into KSC launches (possibly serviced by the low inclination space station) and VAFB launches (possibly serviced by facilities at high inclinations). Within these categories the model is further divided according to the general accommodation needs of the mission.

MISSION MODEL STRUCTURE

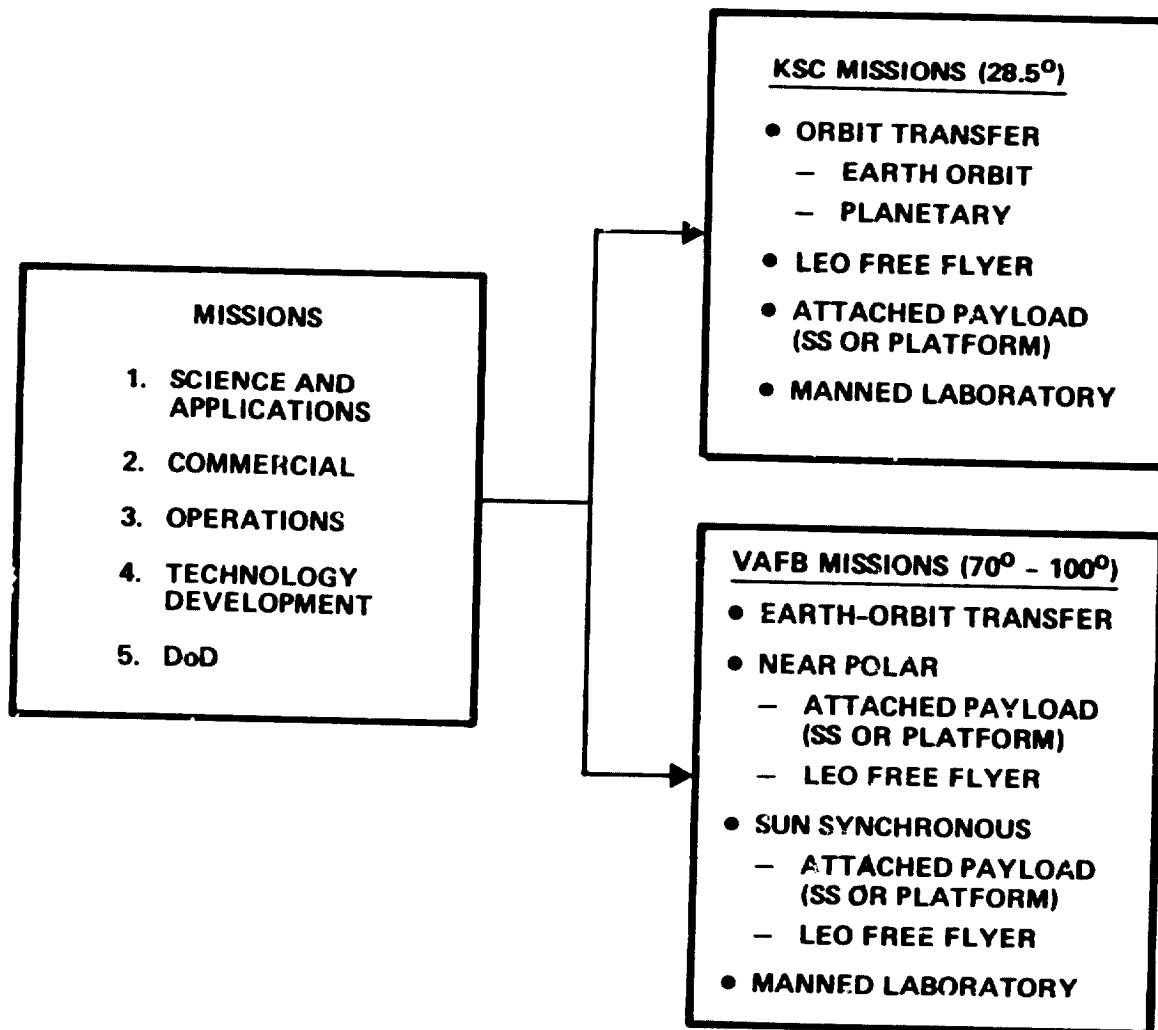

KSC LAUNCHES
(Sample Mission Model Page)

A sample page from TRW's mission model is displayed on the facing page. The model (which is 5 pages in length) defines for each mission the year of launch, servicing events, and either the payload return or the mission end. Some missions feature multiple vehicles, payloads, and launch events as indicated. The schedule shows no finer resolution than one year. Returns following a launch in the same year imply six-month missions. Returns in the subsequent year indicate one-year missions. The missions in the model are identified in terms of their acronym at the left side of the table.

The mission model and corresponding mission list are contained in the splinter meeting document entitled "Mission Requirements Working Group Briefing".



KSC LAUNCHES



		YEAR											
		PRE	1990	1991	1992	1993	1994	1995	1996	1997	1998	1999	2000
		1990											
1. CO-ORBIT FREE- FLYER	!ST	L,R	L		S		R			S		S	
	!GRD	L	S		E								
	!SCDM								L		S		
	!AXAF			L		S		S		S		S	
	!EM			L		E				E		L	
	!LDR					L		S		S		S	
	!VLST										L		S
2. TRANSFER, EARTH ORBIT	!AOVLBI											L	
	!OPEN			L3									
	!GOES		L				L		L		L		L
	!GMS									L			
	!CCP									L	L	L2	L3
	!CCS-A		L8	L4	L4	L4	L3	L2	L2	L2	L1	L1	L1
	!CCS-B		L5	L4	L3	L3	L4	L2,S	L2,S	S2	S2	S2	S2
	!CCS-C		L4	L5	L6	L6	L7	L8	L6,S2	L2,S6	L5,S3	L7	L4,S2
	!GPS		L4	L4	L4	L4	L4	L4	L4	L4	L4	L4	L4
	!DDEG		L7	L6	L6	L11	L8	L3,S2	L4,S3	L2,S6	L2,S7	L3,S2	L3,S5
	!DDEH		L1	L4	L3	L2	L2	L1	L2	L2	L2	L2	L2

ORIGINAL PAGE IS
 OF POOR QUALITY

LEGEND

- L = LAUNCH
- S = SERVICE
- R = RETURN
- E = END OF MISSION
- L4, S4 = LAUNCH 4 VEHICLES, SERVICE 4 VEHICLES

Space Station Orbit Options

INTENTIONALLY BLANK PAGE NOT REPRODUCED

PAGE 47 INTENTIONALLY BLANK



SPACE STATION INCLINATION

The 28.5° inclination space station satisfies the largest traffic volume by far. At this inclination, MPS, Life Science and Astrophysics missions are accommodated at minimum cost (due to the highest lbs./\$ LEO launch capability at that inclination). The 28.5° inclination is also well suited for staging GEO and planetary launches. A few missions prefer 57° but this inclination is largely a compromise between 28.5° and polar orbits. Polar orbit requirements are primarily for earth viewing. Our assessment is that the polar orbit missions needed before 2000 can be accommodated with space platforms and free-fliers serviced/tended by STS.

SPACE STATION INCLINATION

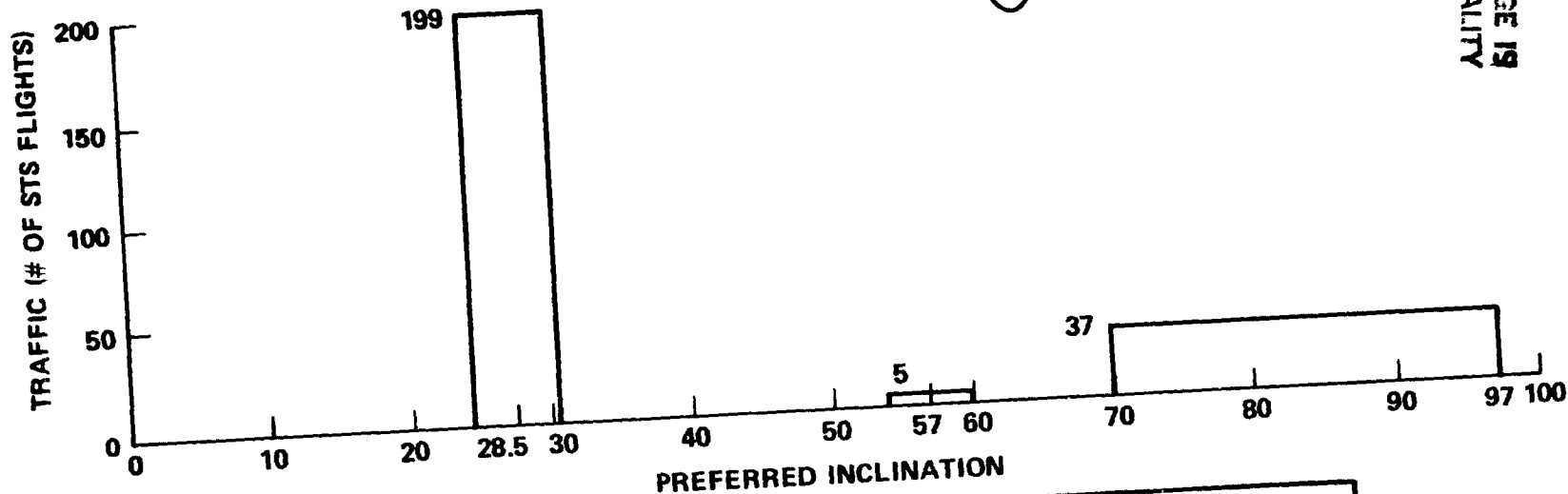
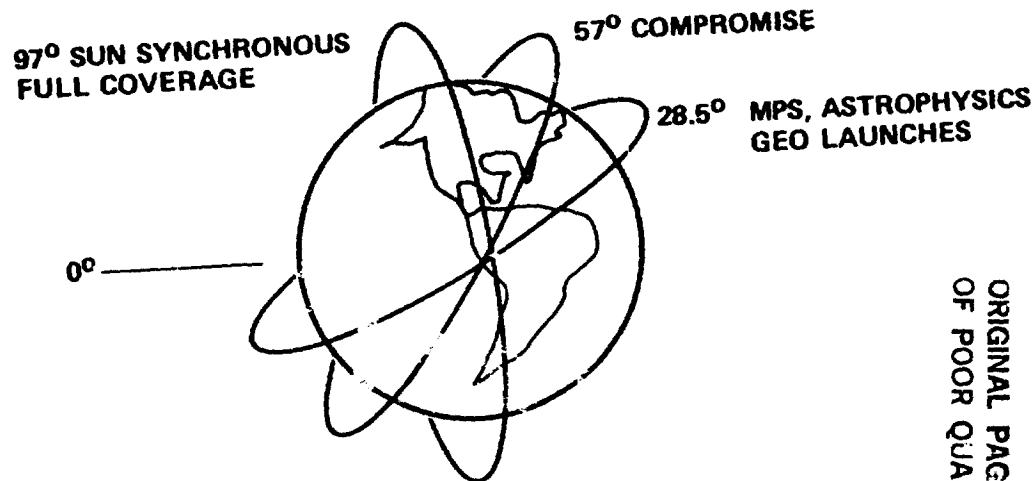

ORIGINAL PAGE IS
OF POOR QUALITY

28.5° INCLINATION PROVIDES GREATEST INITIAL PAYOFF

Phase Mission Requirements

PRECEDING PAGE BLANK NOT FILMED

PAGE 51 INTENTIONALLY BLANK



RECOMMENDED CAPABILITY EVOLUTION

The recommended capability evolution is summarized on the facing page. The first step (1990-1991) provides significant capabilities. The space based OTV capability added in 1995 has such a significant payoff that providing it earlier may be desirable.

RECOMMENDED CAPABILITY EVOLUTION

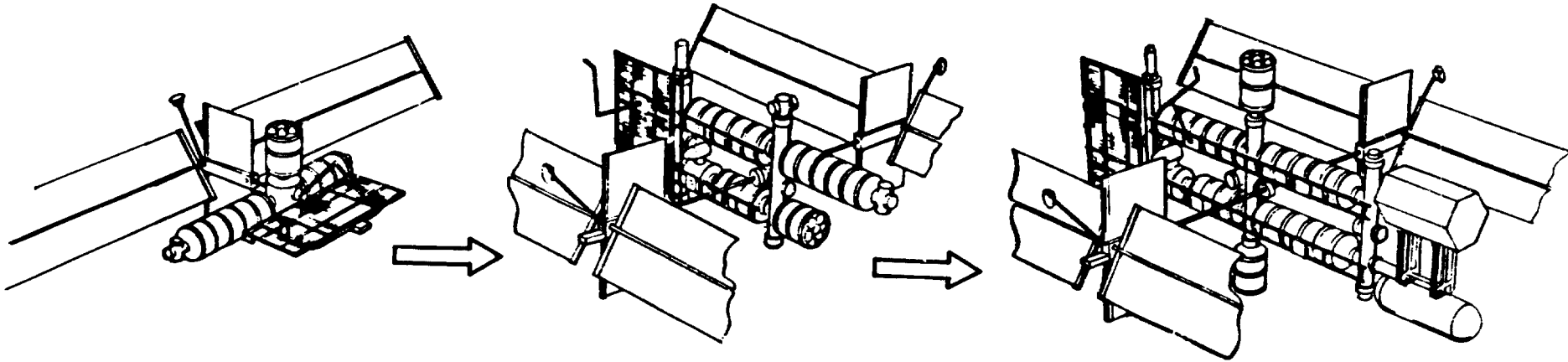

1990 - 1991	1995	2000
<p>SATELLITE SERVICING</p> <p>TMS BASING</p> <p>ATTACHED PAYLOADS</p> <p>MANNED LABORATORY</p> <p>EARLY STRUCTURE ASSEMBLY</p>	<p>SPACE-BASED OTV</p> <p>SATELLITE REPAIR, REFURBISH</p>	<p>LARGE STRUCTURE ASSEMBLY</p> <p>ORIGINAL PAGE 19 OF POOR QUALITY</p>

SPACE STATION PHASED MISSION REQUIREMENTS

The time-phased mission requirements for a 28.5° inclination Space Station are given on the facing chart. The power and data requirements are totals that represent the need of all payloads on-orbit at one time. The manned laboratory requirements specify laboratory volume in terms of number of standard 19" racks. An assumed volume of 2 cubic meters per rack allows for both equipment and manned working space.

The initial Space Station at 28.5° inclination will require only 3 crew members since initially the lab facilities are not available and hence, payload specialists are not required. These are added in the following year. Subsequent increases in crew size are due to added space station capacity for both servicing and direct payload operations and experiment evaluation.

SPACE STATION
 PHASED MISSION REQUIREMENTS



	1990 - 1991	1995	2000
MISSION DEDICATED POWER, KW	15	22	22
NUMBER OF PAYLOAD PORTS	4	6	6
VIEWING	SOLAR CELESTIAL EARTH	SOLAR CELESTIAL EARTH	SOLAR CELESTIAL EARTH
PEAK DATA, MBPS	60	60	60
MANNED LAB VOLUME, EQUIVALENT 19" RACKS	18	26	26
REQUIRED CREW	3 → 5	8	10

SPACE PLATFORM PHASED MISSION REQUIREMENTS

Time-phased payload requirements for space platforms at 28.5° and 97° inclinations are shown on the facing page. The 97° inclination attached payload data requirements are considerably larger than those for missions at the lower inclinations due to the large data rates associated with remote sensing/surveillance observations.

SPACE PLATFORM PHASED MISSION REQUIREMENTS



	1990	1995	2000
SPACE PLATFORMS AT 28.5° INCLINATION			
MISSION DEDICATED POWER, KW	4	11	11
NUMBER OF PAYLOAD PORTS	2	5	5
VIEWING	CELESTIAL	CELESTIAL	CELESTIAL
PEAK DATA, MBPS	7	11	11
SPACE PLATFORMS AT 97° INCLINATION			
MISSION DEDICATED POWER	12	18	22
NUMBER OF PAYLOAD PORTS	5	10	10
VIEWING	CELESTIAL EARTH	CELESTIAL EARTH SOLAR	CELESTIAL EARTH SOLAR
PEAK DATA, MBPS	300-600	300-750	300-750



PRELIMINARY COPY. PRINTING NOT FILMED

Introduction and Conclusions

User Needs/Mission Requirements

Architecture/Mission Implementation

Program Costs and Benefits

Summary and Recommendations



- Architecture
- Requirements
- Trades
- Configuration
- Ground Segment
- Technology

THIS PAGE BLANK NOT FILLED

Architecture

PAGE 61 INTENTIONALLY BLANK

SPACE STATION INFRASTRUCTURE ELEMENTS

The total Space Station infrastructure includes not only the Space Station (SS) itself, but all other supporting elements. The existing Space Transportation System provides the means for launching and returning all other elements of the infrastructure. Orbital Transfer Vehicles (OTV's) are required to boost spacecraft from the Orbiter or SS to GEO or other high-energy orbits.

The Teleoperator Maneuvering System (TMS), or equivalent provides a space tug, placing and retrieving spacecraft or payloads relative to the Orbiter, SS, or OTV's. Ground operations are required to support all portions of the space elements.

Existing and future free-flying spacecraft, of all sizes, purposes, and in all orbits are an element. Small unmanned platforms, devoted to single payload missions, but having changeable payload capabilities, are another element. Larger, Space Platforms, which have capabilities of several ports, supporting multiple payload disciplines, are also required.

Subsequent charts will define the assumed scenarios, the mission requirements, and will select an evolving architecture (scenario).

Space Station Infrastructure Elements

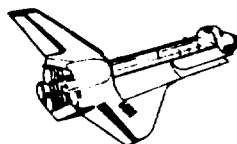

**SPACE TRANSPORTATION
SYSTEM**

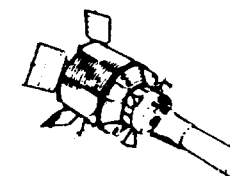

**FREE-FLYING
SPACECRAFT**



**TELEOPERATOR
MANEUVERING
SYSTEM**

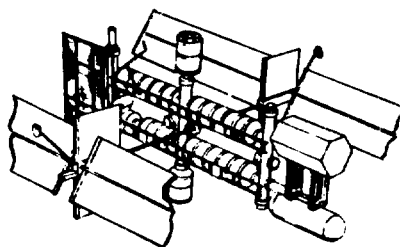

SPACE STATION

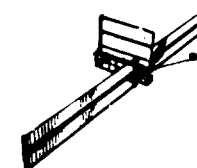

**SMALL UNMANNED
PLATFORMS**



**ORBITAL TRANSFER
VEHICLES**



GROUND OPERATIONS

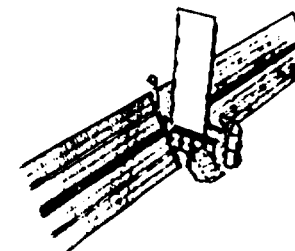

SPACE PLATFORMS

ORIGINAL PAGE IS
OF POOR QUALITY

SPACE STATION ARCHITECTURE SCENARIOS

Six different candidate scenarios were examined. All had free-flying spacecraft, small unmanned platforms, TMS and OTV's in common.

Scenario 0 is the baseline. This assumes neither SS or SP. It is what would/could be done without those elements. Scenario 1 adds Space Platforms. Scenario 2 has Space Stations, but no Space Platforms. Scenario 3 has an SS at LEO and one or more SP's at PEO.

Scenario 4 has SS's at LEO and PEO and an SP at LEO. Scenario 5 is like scenario 4, except that an extended-stay Orbiter is used as part of the initial SS.

SPACE STATION ARCHITECTURE SCENARIOS



	SCENARIO 0	SCENARIO 1	SCENARIO 2	SCENARIO 3	SCENARIO 4	SCENARIO 5**
SS LEO *						
SS PEO						
SP LEO*						
SP PEO						

ORIGINAL PAGE 19
 OF POOR QUALITY







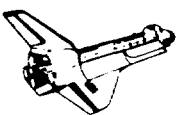
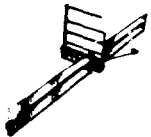

*LEO – LOW INCLINATION (28.5°) LOW EARTH ORBIT
 PEO – POLAR (97°) LOW EARTH ORBIT
 **USES STS AS PART OF INITIAL SS
 ALL SCENARIOS INCLUDE FREE FLIERS, SMALL UNMANNED PLATFORMS, TMS, OTV'S

MISSION ACCOMMODATIONS BY SS SCENARIOS

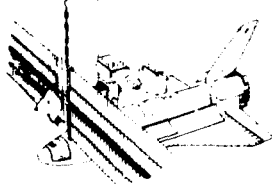
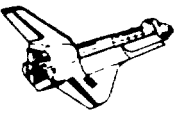
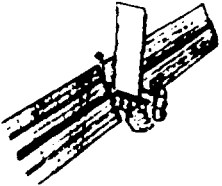
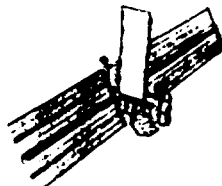
The phased mission requirements are developed with as little consideration of Space Station scenarios as possible. Each of the scenarios is then applied to the requirements and the appropriate number of facilities and Shuttle flights are employed to best meet the phased requirements. The effectiveness of the scenarios is then essentially measured in terms of relative costs. This chart identifies how the different mission categories: free-flying vehicles, space platform payloads, space station payloads, and manned laboratory are accommodated by the available facilities of each scenario. As indicated, the principal difference between the scenario accommodations and the mission requirements is in the case of the manned laboratory. Without a space station, scenarios 0 and 1 "best" accommodate the lab requirements by providing two Spacelab flights each year that allow up to 4-weeks of lab operation per year. This is in contrast to the 52 weeks of operation afforded by scenarios 2 through 5 that feature space stations and permanent manned laboratories.

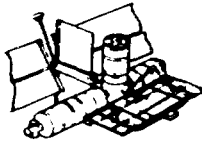
MISSION ACCOMMODATIONS BY SS SCENARIOS

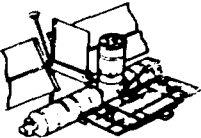

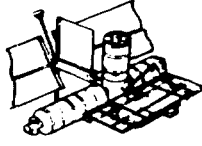
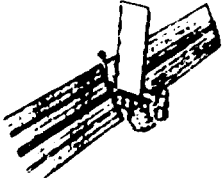
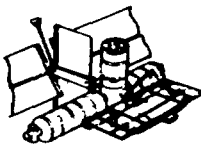
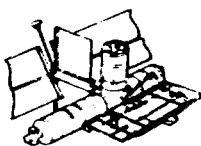
SCENARIO	REQUIREMENTS/ACCOMMODATIONS APPROACH			
	SERVICE FREE-FLYERS	ACCOMMODATE PLATFORM PAYLOADS	ACCOMMODATE SPACE STATION PAYLOADS	ACCOMMODATE MANNED LABORATORIES
0				
1				
2				
3-5				

- ONLY MAJOR CAPABILITY IMPACT IS MANNED LAB ACCOMMODATIONS IN SCENARIOS 0 AND 1
- ANY SCENARIO WITH MANNED SS WILL SATISFY ALL MISSIONS -- SCENARIOS 2 - 5
- OTHER SCENARIOS DIFFER HOW/WHERE MISSIONS ARE ACCOMMODATED

ORIGINAL PAGE IS
OF POOR QUALITY

SPACE STATION SCENARIO COMPARISON

(1990 - 2000)

The total number of Orbiter flights for each scenario varies from a minimum of 281 (Scenario 1) to a maximum of 329 (Scenario 0). Despite the fact that Scenario 0 does not include the building and maintaining of a SS, the lower packing of payloads into the Orbiter results in the higher number of flights. The SS presence provides a greater efficiency of Orbiter manifesting.

For all scenarios, by far the greatest percentage of flights are payload flights. Maintaining a SS requires about $3 \frac{1}{2}$ times as many flights as does the building of it.

Orbital Transfer Vehicles (OTV's), Apogee Kick Motors (AKM's), and Unmanned Platforms (UP's) are part of the payload flights. These units are lifted by the Orbiter to LEO and put into service at that time.

SPACE STATION SCENARIO COMPARISON (1990-2000)

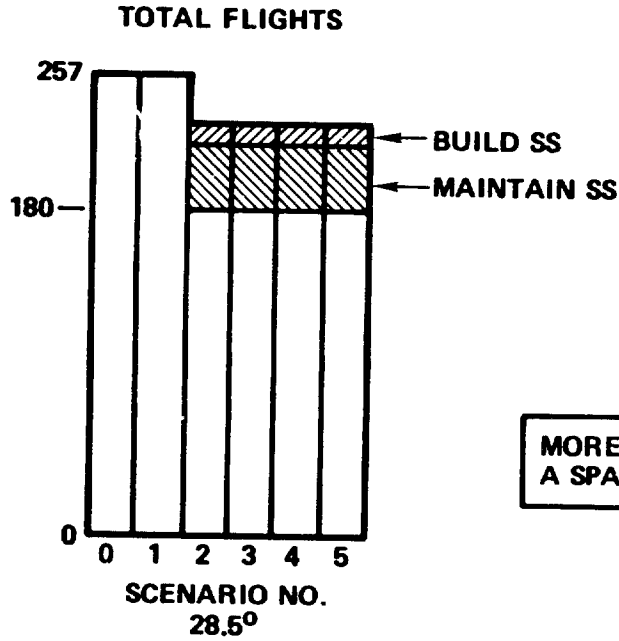

MORE ORBITER FLIGHTS ARE REQUIRED WITHOUT A SPACE STATION THAN WITH ONE.

ORIGINAL PAGE 18
OF POOR QUALITY

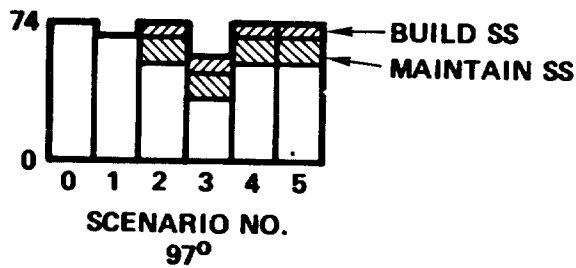

SCENARIO 3 EVOLVING ARCHITECTURE

This chart illustrates the evolution of the major elements of the SS program from 1984 through 2000. Some of these elements are already in existence. For example, many Free Flyers are in use and the Orbiters are moving from the test phase into the operational phase. OTV's, such as the Centaur are proven, and upgraded versions are under consideration.

The manned Space Station (SS) will commence with a small four man vehicle at 28.5° LEO in 1990 and evolve through an interim stage, to a large multi-purpose station in the year 2000, capable of housing a permanent crew of ten or more. Platforms of various sizes will join the SS beginning in 1993 with small Unmanned Platforms and followed by larger Space Platforms capable of carrying several large payloads. A teleoperator to service the satellites and platforms is needed by 1990.

Improved, automated ground systems will be needed to support all of these space activities.

SCENARIO 3 EVOLVING ARCHITECTURE

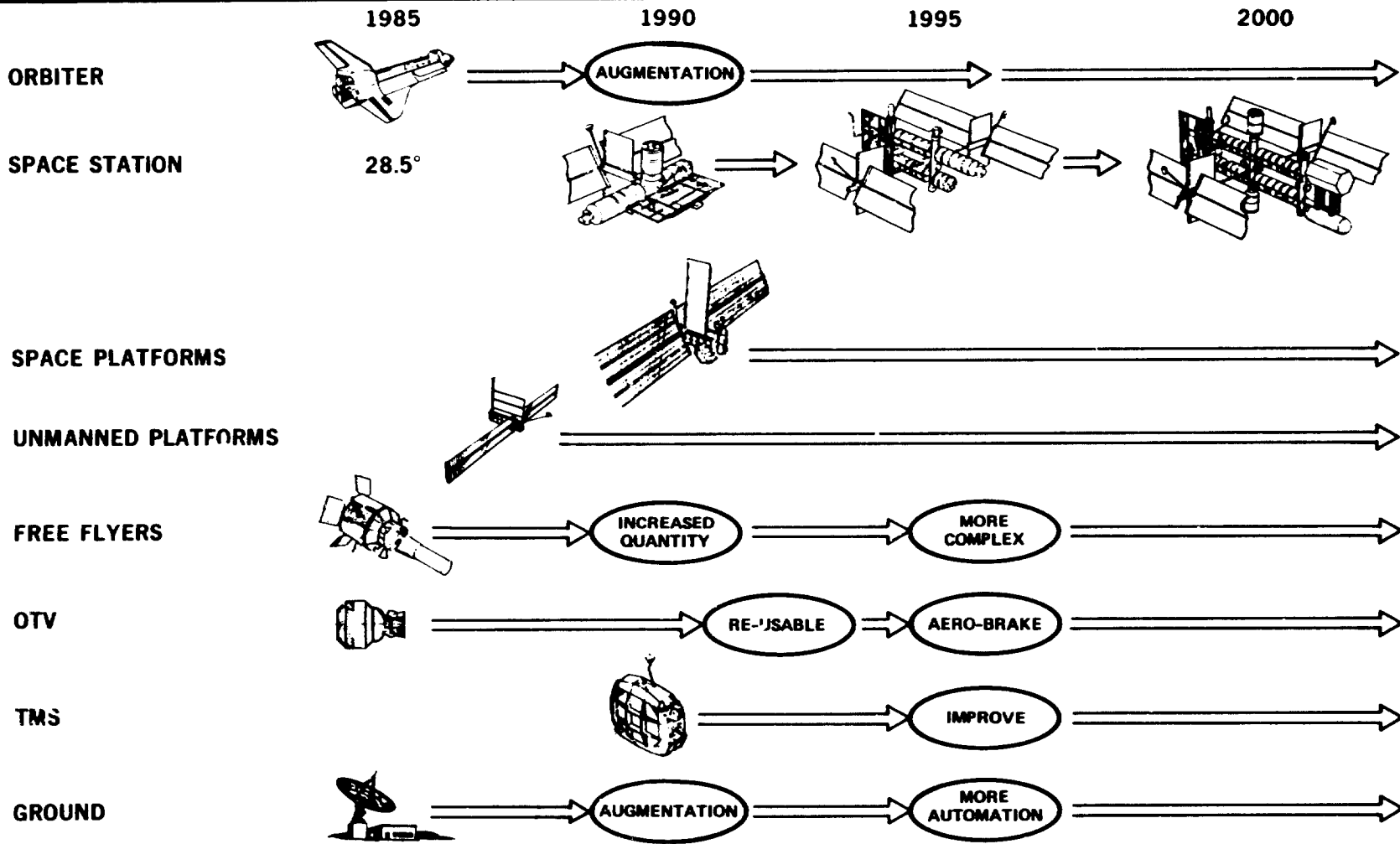

ORIGINAL PAGE IS
 OF POOR QUALITY

SELECTED FOR HIGHEST BENEFITS OF MANNED SS SCENARIOS

Requirements

PRECEDING PAGE BLANK NOT FILMED

ASSUMED SYSTEM SAFETY REQUIREMENTS

Crew safety is based on redundancy in all aspects of life sustaining equipment and the means of using them.

The structure of the Habitable Modules is intended to provide protection from particles of reasonable size. Major failures are provided for by redundant Habitable Modules.

It is assumed that Orbiter rescue is available only at sufficient notice and this contingency is provided against by installing 21 days emergency supplies in all Habitable Modules.

In the event of a predictable solar flare the crew will be evacuated by the Orbiter. An emergency reentry vehicle (ambulance) could provide for quick return for medical emergencies.

ASSUMED SYSTEM SAFETY REQUIREMENTS



- LIFE SUSTAINING CAPABILITIES SHALL BE FAIL OPERATIONAL, FAIL OPERATIONAL, FAIL SAFE
- INDEPENDENT HABITABLE AREAS PROVIDE CREW SAFETY
- AT LEAST TWO:
 - AIRLOCKS
 - ORBITER BERTHING PORTS
 - EGRESS PATHS PER HABITABLE AREA
- NATURAL ENVIRONMENT PROTECTION FOR EACH HABITABLE AREA

**ASSUMED SAFETY REQUIREMENTS DRIVE
SPACE STATION CONFIGURATION**

ASSUMED SYSTEM REQUIREMENTS

The SS is an evolving modular system based on the use of the Orbiter for transportation, assembly and supply. All SS modules are compatible with the Orbiter cargo size and weight restrictions.

The modular configuration is predicated on the idea of having no evolutionary dead ends. All modules required at any stage are used from then on. No modules need be discarded or returned to the ground.

The resource module of the SS, which supplies power and other subsystem functions, is common with the Space Platform. This allows cost savings, with no sacrifice in capabilities. In addition, all habitable modules are of a common size and design.

ASSUMED SYSTEM REQUIREMENTS

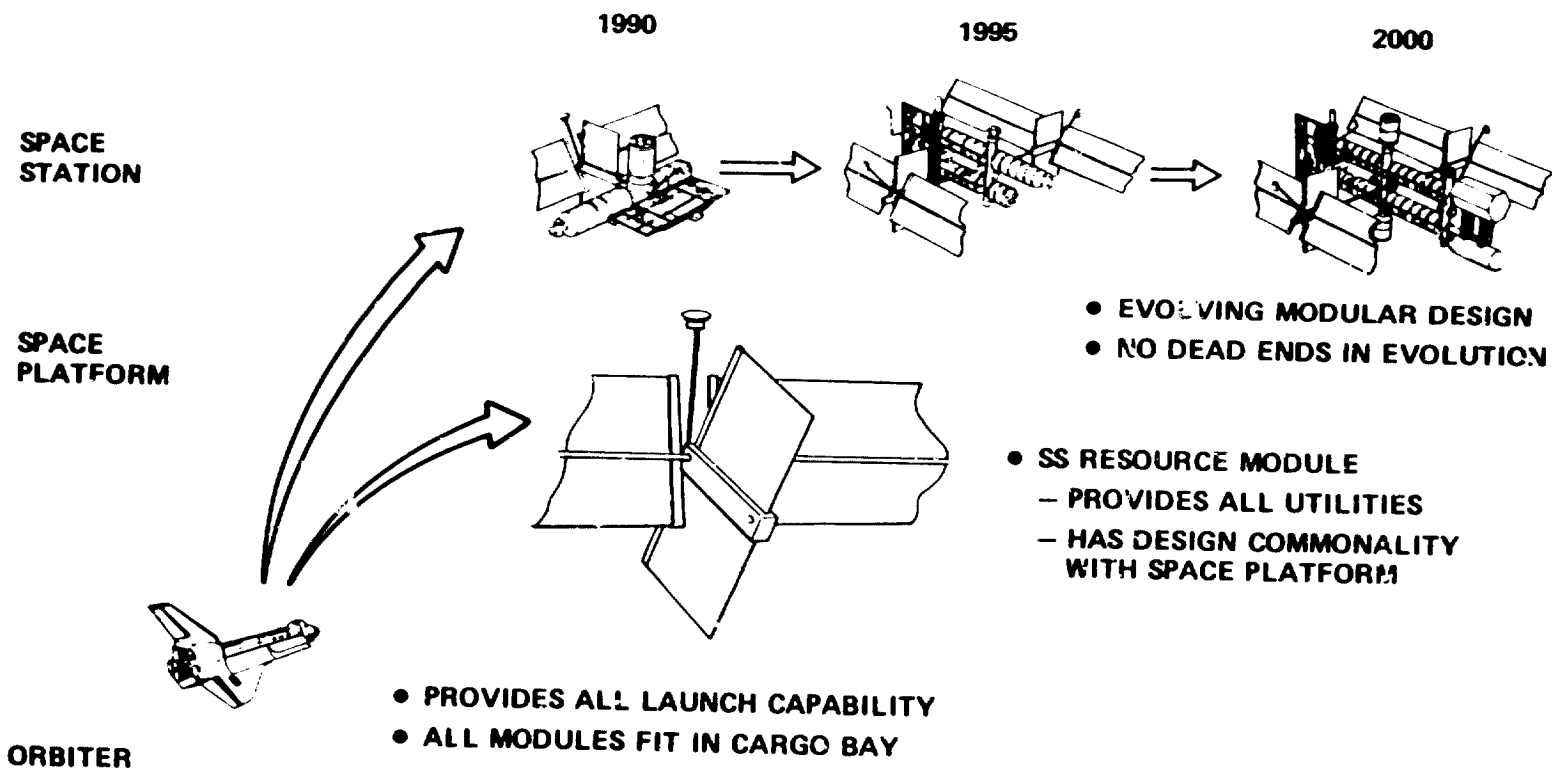

MINIMUM PROGRAM COST FROM MAXIMUM COMMONALITY

ORIGINAL PAGE 19
OF POOR QUALITY

PAYLOAD ACCOMMODATION

The main payload requirements that drive the SS configuration are crew size, power requirements and internal volume requirements.

The selected configuration accommodates both external and internal payloads. External payloads may mount to any of three ports on each resource module. These payloads draw their power and cooling directly from the resource module(s). Other external payloads may mount to ports scattered about the other SS modules. These payloads must provide their own cooling.

Internal payloads are accommodated inside the habitable modules (such as the manned laboratory module). They draw their cooling from the module they are in. Internal payload changeout can be effected either by replacing portions that will pass through the ports or by designing the modules to open to their full diameter.

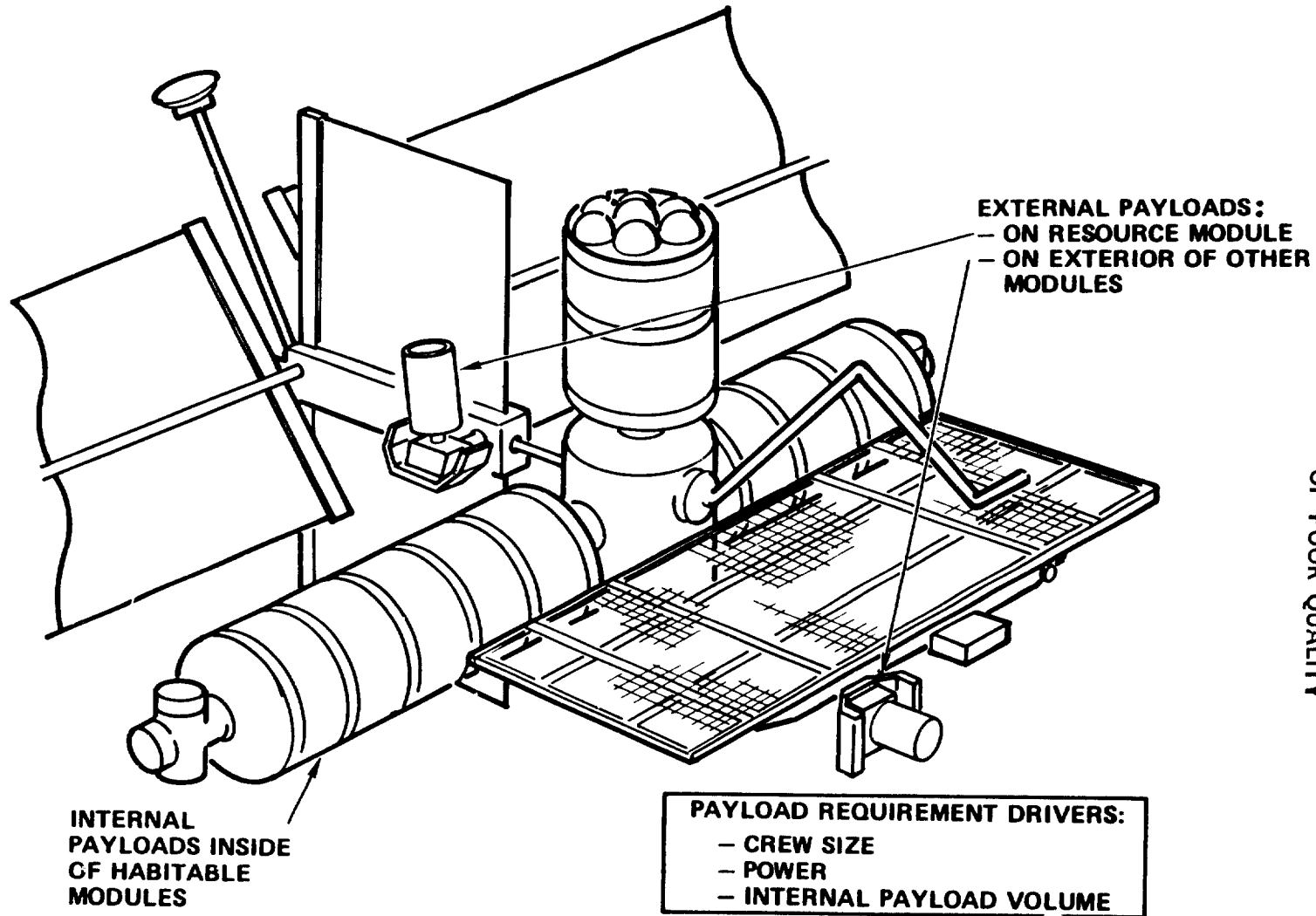

ORIGINAL PAGE IS
OF POOR QUALITY



ASSUMED RESUPPLY CONCEPT

Resupply is based on the use of Logistics Modules transported by the Orbiter, then berthed to the SS where they remain until exchanged for fresh Logistics Modules on the next resupply flight.

The Logistics Modules carry up to the SS all consumables, small repair parts, supplies, etc., and return to Earth with such items as trash and used components. The size of the Logistics Modules depends on the orbit inclination (Orbiter lift capability), resupply cycle and other variables.

ASSUMED RESUPPLY CONCEPT



EACH CONTAINS 21 DAYS
EMERGENCY SUPPLIES

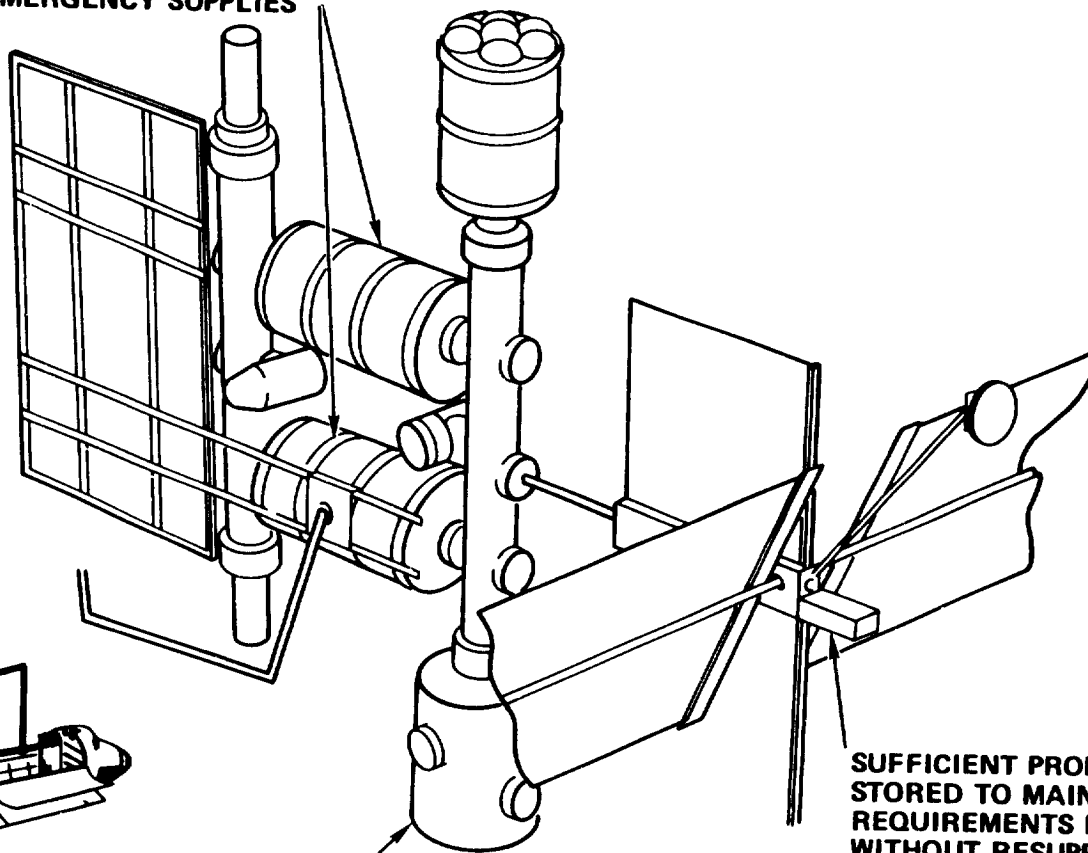

90 DAY NORMAL
REVISITS ASSUMED

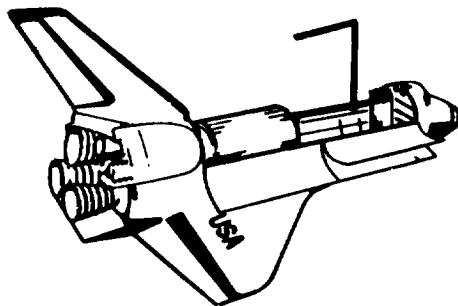

ORIGINAL PAGE IS
OF POOR QUALITY

SUFFICIENT PROPELLANT WILL BE
STORED TO MAINTAIN THE SS
REQUIREMENTS FOR 6 MONTHS
WITHOUT RESUPPLY

LOGISTICS MODULES SUPPLY
ALL CONSUMABLES NECESSARY

ASSUMED RESUPPLY CONCEPT DRIVES THE CONFIGURATION



PRECEDING PAGE BLANK NOT FILMED

Trades

CRITICAL TRADE SUMMARY

The trades shown in the chart are only a few of those made, but are the more critical in that their conclusions have the greatest effect on the SS configuration.

Solar arrays and conventional (NiCd or NiH₂) batteries were chosen as existing, low-risk technology. Concentrator solar arrays and reversible fuel cells exist as future, enhancing technology of high promise. Nuclear power requires development, but would have many advantages, particularly for DoD missions.

All SS modules were sized to fit within the Orbiter. The advantages of larger modules were minor compared to the cost of their transportation system. Both the thermal and ECLS systems should be modularized and decentralized as far as possible.

The life support systems should be initially partially closed loop relative to O₂ and H₂O reclamation, evolving to fully closed loop systems. A reduction in resupply costs becomes the driver.

The approach taken for crew hazard survival is Orbiter rescue for major hazards, multiple habitability spaces until Orbiter rescue or repair, and the possibility of an ambulance for immediate return for medical emergencies.

CRITICAL TRADE SUMMARY



TRADE	CANDIDATES	INITIAL SELECTION	SELECTION RATIONALE
		GROWTH SELECTION	
POWER SOURCE	LIGHTWEIGHT SOLAR ARRAY CONCENTRATOR SOLAR ARRAY NUCLEAR FUEL CELLS		COST, SAFETY, WEIGHT TO ORBIT
ENERGY STORAGE	BATTERIES REVERSIBLE FUEL CELLS ENERGY WHEELS		EXISTING TECHNOLOGY, SAFETY, P
HABITABLE MODULE TRANSPORTATION	USE ET ACC INSIDE ORBITER		EXISTING CAPABILITY, COST, RISK, NEED
THERMAL CENTRALIZATION	CENTRALIZED PARTIALLY CENTRALIZED DE-CENTRALIZED		COST, PRACTICALITY, REDUNDANCY
LIFE SUPPORT SYSTEM CENTRALIZATION	CENTRALIZED DE-CENTRALIZED		SAFETY, REDUNDANCY, GROWTH
LIFE SUPPORT SYSTEM LOOP CLOSURE	OPEN CYCLE PARTIALLY CLOSED FULLY CLOSED		RESUPPLY COST, LONG TERM CONVENIENCE AND COMFORT
CREW HAZARD SURVIVAL	DEDICATED SAFE HAVEN MULTIPLE HABITABILITY SPACES ESCAPE MODULE (LIFEBOAT) EMERGENCY RESCUE MODULE (AMBULANCE) ORBITER RESCUE		COST VS. SAFETY

SS ALTITUDE AND REVISIT STRATEGY

One of the most significant systems trades was made to determine the optimum altitude for the SS. This optimization reduces both Orbiter and SS fuel requirements.

It was determined that a boost/decay strategy was most efficient for the SS, as compared to maintaining a constant altitude. Using this strategy, the SS would boost itself (following an Orbiter visit) to an altitude such that it would decay to the rendezvous altitude in the revisit period (90 days assumed).

The optimum altitudes are shown on the chart as a function of year. The atmospheric drag peaks in 1991 and 2002. The small initial SS and medium-sized interim SS would both rendezvous at 160 nmi. The large growth SS would rendezvous at 185 nmi.

The traffic density assumed (6 to 12 revisits per year) tends to force the altitude down since Orbiter capability becomes more important than SS drag makeup.

SS ALTITUDE AND REVISIT STRATEGY

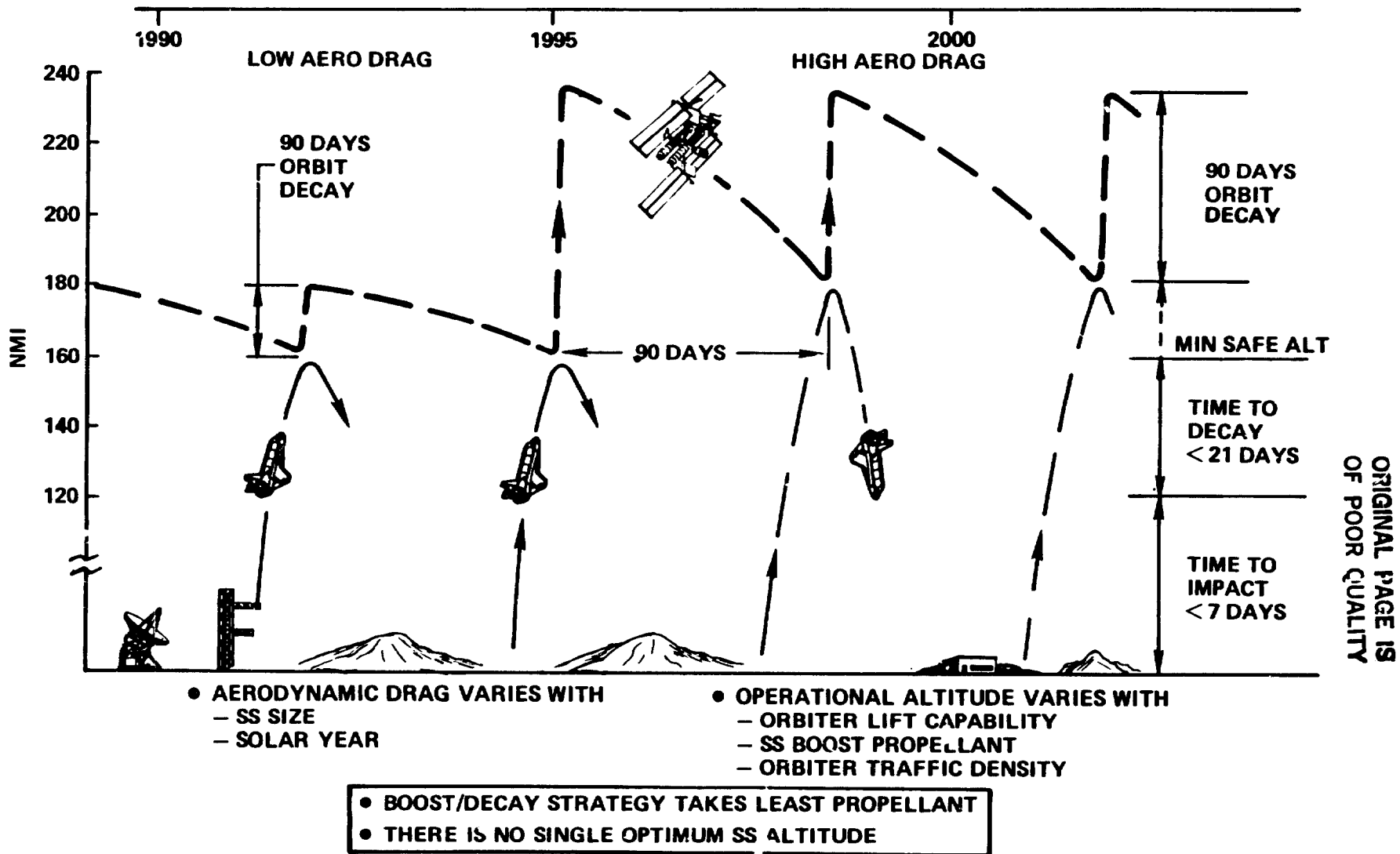

Configuration

PRECEDING PAGE BLANK NOT FILMED

SS EVOLUTIONARY GROWTH

This chart depicts the evolution of the SS's from initial, through interim to growth configurations giving particulars of size, weight, power and incremental capability.

SS EVOLUTIONARY GROWTH



<u>ORBIT</u>	<u>YEAR</u>	<u>ORBITER FLIGHTS</u>	<u>CREW SIZE</u>	<u>NET POWER (kW)</u>	<u>WT. (KLBS)</u>	<u>SIZE-FT (H x L x W)</u>	<u>INCREMENTAL CAPABILITY</u>
28.5°	1990	4	5	30	154	66 x 240 x 120	ATTACHED P/L's, LABORATORY, SATELLITE SERVICING, TMS BASING
	1995	7	8	60	235	72 x 240 x 210	SPACECRAFT ASSEMBLY AND CHECKOUT
	2000	10	10	60	344*	102 x 240 x 210	REFUELING ROTV's
97°	1995	5	3	30	109	66 x 240 x 100	ATTACHED P/L's, SATELLITE SERVICING, TMS BASING
	2000	7	3	30	152	102 x 240 x 132	SPACECRAFT ASSEMBLY AND CHECKOUT

*CRYOGENIC FUEL NOT INCLUDED

FLIGHT 4 CONFIGURATION (5 CREW)

The initial SS shown, requires four Orbiter launches to lift the modules to LEO at 28.5° inclination. The Resource Module is lifted first followed by the Short Habitability Module and the Junction Module on the second launch. The third Orbiter launch carries four crew plus the Assembly Area Platform, the Airlock Modules, a Logistics Module and payloads. The SS is now then a functioning system capable of supplying many services.

The Manned Laboratory Module occupies the whole of the Orbiter payload bay, and together with the fifth member of the SS crew comprises the cargo for the fourth launch.

Flight-4 Configuration (5 Crew)

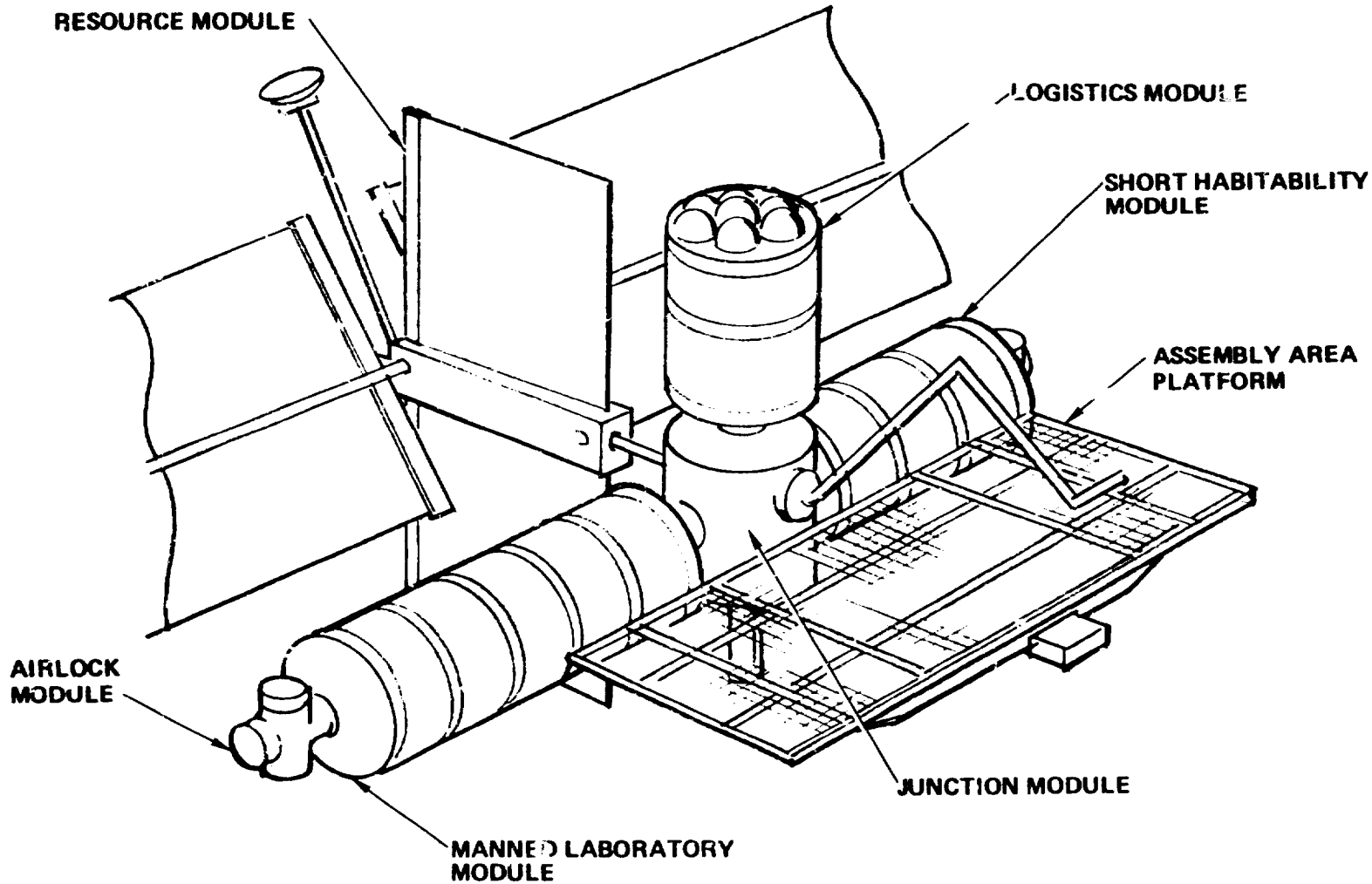

ORIGINAL PAGE IS
OF POOR QUALITY

FLIGHT 7 CONFIGURATION (8 CREW)

The evolution of the SS from 1991 to 1995 doubles its power through the addition of a second Resource Module. A second Habitability Module, more airlock modules, and two interconnection tunnel modules are also added.

A rail and trolley system enables the Remote Manipulator System to move freely about the station. A command module provides clear vision of the rail and assembly areas.

Flight-7 Configuration (8 Crew)

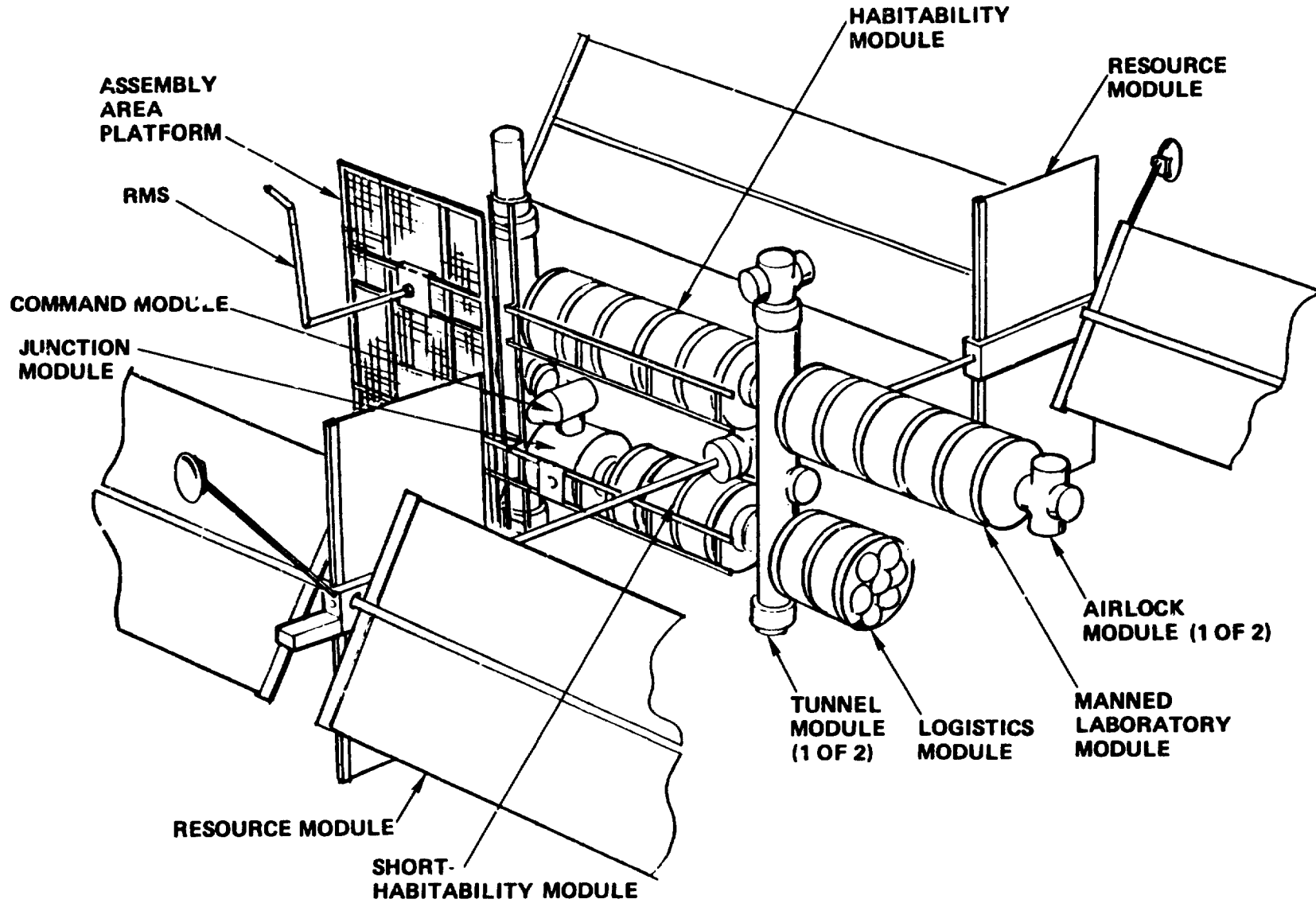

ORIGINAL PAGE 19
OF POOR QUALITY

FLIGHT 11 CONFIGURATION (10 CREW)

During the period 1995 to 2000 the SS further evolves to the fully-developed station shown, capable of performing many functions and supporting a crew of 10 or more for long periods of time.

A second Habitability Module, a third Tunnel Module and a second Logistics Module are added to house the growing crew. A Hangar Shelter Module allows sheltered servicing of OTV's and spacecraft. The rail system extends into this hangar. A Cryogen Tank Module is also added to allow refueling Orbital Transfer Vehicles.

Flight-11 Configuration (10 Crew)

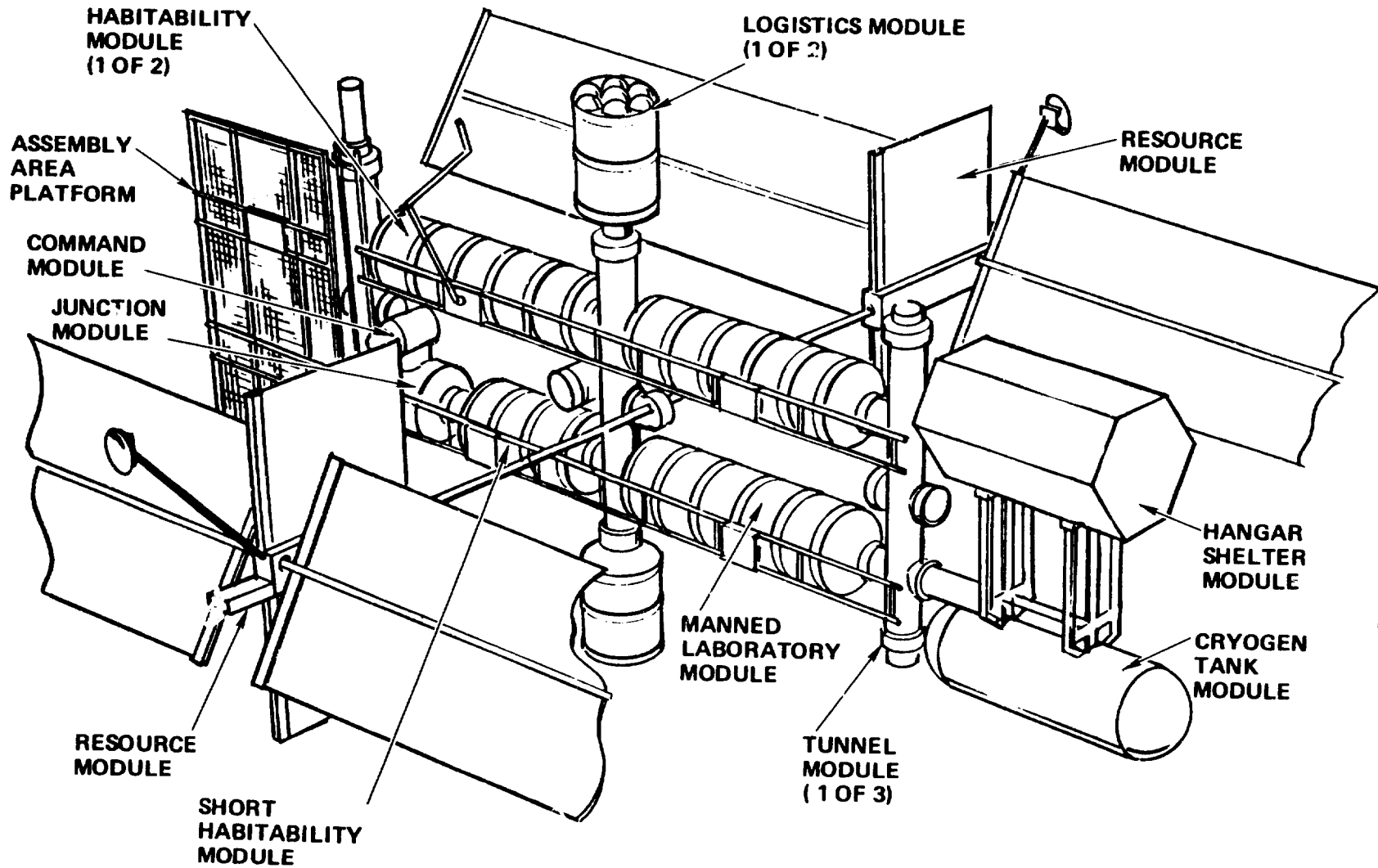

ORIGINAL PAGE IS
OF POOR QUALITY

PRECEDING PAGE BLANK NOT FILLED

Ground Segment



ASSUMED LAUNCH AND LOGISTICS GROUND OPERATIONS

To reduce costs, a protoflight concept was assumed for all modules except for one habitable module. For that representative module, an engineering model will be used for ground interface verification, training, etc.

Existing facilities at KSC are committed to Spacelab, and VAFB lacks suitable facilities for Space Station processing. A trade study indicated that a CITE-type simulator/emulator offers a good balance of capabilities and cost.

ASSUMED LAUNCH AND LOGISTICS GROUND OPERATIONS



- PROTOFLIGHT CONCEPT ASSUMED
- SINGLE HI-FIDELITY HABITABILITY MODULE ON GROUND
- DEDICATED SS GROUND PROCESSING FACILITIES ARE NEEDED
- SIMULATOR/EMULATOR REQUIRED TO TEST AND VERIFY INTERFACES

MISSION OPERATIONS GROUND SEGMENT ASSUMPTIONS

In order to reduce the ground operations crew size, it is assumed that it will be necessary to have increasing space segment autonomy and ground segment automation.

A maximum use must be made of existing and planned NASA and DoD facilities. A centralized control and communications capability (the data handling facility) is essential. All interfaces must be established at the beginning, allowing independent evolutionary growth/change of the other facilities. The security provisions must be included in the communications complex and interfaces from the beginning. Payload Operations Control Centers may be added as needed.

MISSIONS OPERATIONS GROUND SEGMENT ASSUMPTIONS



- DECREASED OPERATIONS CREW SIZE
 - INCREASING SPACE SEGMENT AUTONOMY
 - INCREASING GROUND SEGMENT AUTOMATION
- CENTRALIZED CONTROL AND COMMUNICATIONS FUNCTIONS
- USES EXISTING AND PLANNED NASA AND DoD FACILITIES
- UNCHANGING INTERFACES
- BUILT-IN SECURITY PROVISIONS

**INITIAL GROUND SEGMENT MUST PROVIDE
FOR EVOLUTION WITH NO DEAD ENDS**

BASELINE SPACE STATION GROUND SEGMENT

This chart shows a diagram of the ground operations segment for a mature Space Station infrastructure. The locations of the control/operations centers are not implied. The Space Station and Space Platform control centers may be together (thus sharing some equipment) or separate. It is assumed that Orbiter control remains with JSC and CSOC.

BASELINE SPACE STATION GROUND SEGMENT

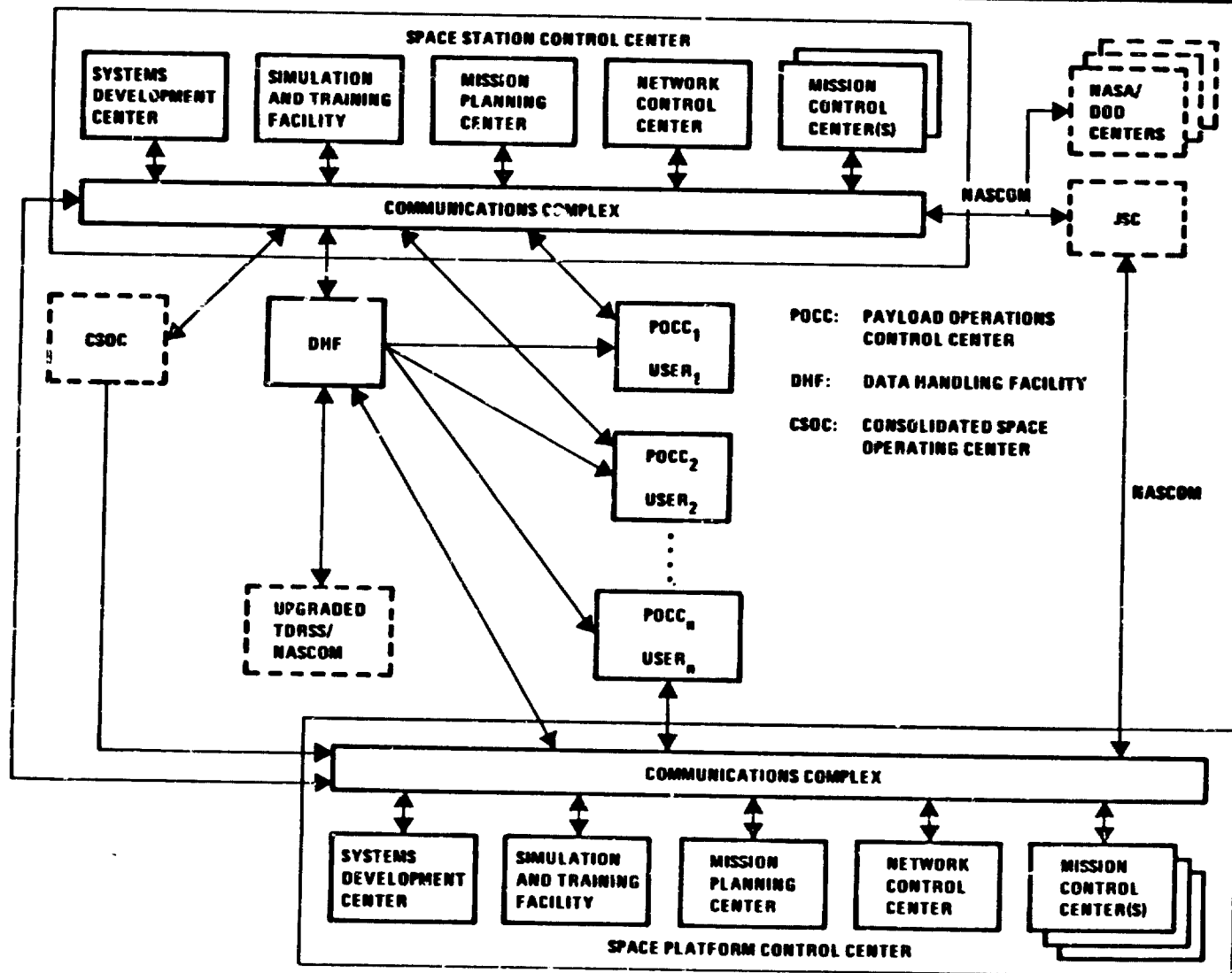

POCC: PAYLOAD OPERATIONS CONTROL CENTER
 DHF: DATA HANDLING FACILITY
 CSOC: CONSOLIDATED SPACE OPERATING CENTER

ORIGINAL PAGE IS
 OF POOR QUALITY

PRECEDING PAGE BLANK NOT FILMED

Technology

PAGE 107 INTENTIONALLY BLANK

ENHANCING TECHNOLOGY

Although we have assumed no new technology as being needed for the initial SS, several technologies would be very useful in reducing cost and improving performance. The SS design must be able to absorb these technologies as they become available. To allow this the "spinal cord" of data bus, electrical power distribution, and fluid lines must be unchanging after initial establishment. Inter-module interfaces must also remain constant from the initial SS.

A more complete discussion of the assumed initial technologies, needed enhancing technologies, and on-going TRW technology development activities will be covered in the Technology Working Group meeting.

- ON-ORBIT CRYOGEN TRANSFER
- OTV AEROBRAKING
- INTEGRATED HYDROGEN/OXYGEN SYSTEMS
- REGENERABLE SPACE SUIT
- WATER AND OXYGEN RECOVERY SYSTEMS
- HIGHER EFFICIENCY SOLAR ARRAYS
- REVERSIBLE FUEL CELLS
- SAFE NUCLEAR POWER
- AUTONOMY, FAULT-TOLERANCE

TECHNOLOGY ENHANCEMENTS CAN:
- REDUCE OVERALL COSTS
- GIVE IMPROVED PERFORMANCE

SATELLITE SERVICING STUDY TDM'S

This chart shows the five TDM's selected for study as a part of the NASA/MSFC contract "Definition of Satellite Servicing Technology Development Missions for Early Space Stations." These TDM's will be discussed in more detail in the Technology Working Group meeting.

SATELLITE SERVICING STUDY TDMs

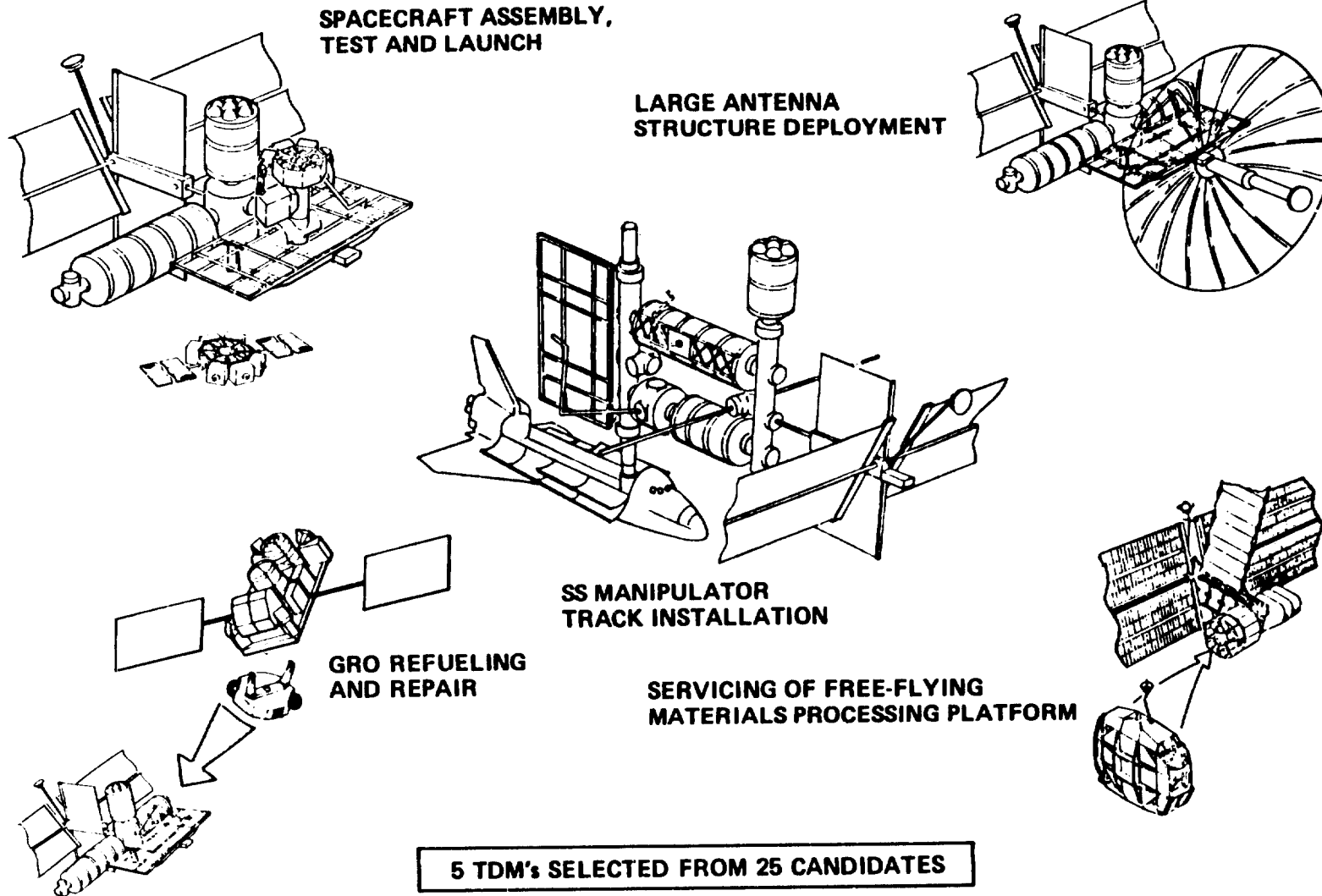

ORIGINAL PAGE IS
OF POOR QUALITY

SS ENHANCES TECHNOLOGY DEVELOPMENT

The space station provides the ideal vehicle for developing and testing new space technologies. Many of these technologies could not be developed, or could not be developed as easily, without the space station.

SS ENHANCES TECHNOLOGY DEVELOPMENT



**MATERIALS PROCESSING
RESEARCH**

**COMMUNICATIONS SYSTEMS
TESTING**

ATTITUDE CONTROL

**LARGE STRUCTURE
MODELING**

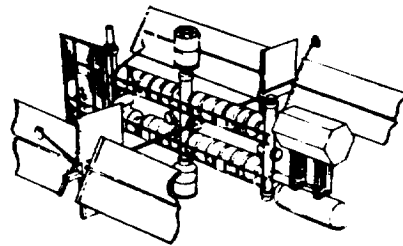

**PLANETARY AUTOMATED
OPERATIONS**

**PRECISION STRUCTURE
ASSEMBLY**

**ON-ORBIT SPACECRAFT
ASSEMBLY AND TEST**

SATELLITE SERVICING

**THE SS IS AN IDEAL SITE FOR
ADVANCED TECHNOLOGY DEVELOPMENT**

ORIGINAL PAGE IS
OF POOR QUALITY

PRECEDING PAGE BLANK NOT FILMED

Introduction and Conclusions

User Needs/Mission Requirements

Architecture/Mission Implementation

Program Costs and Benefits

Summary and Recommendations



- **Cost Modeling**
- **Benefit Quantification**
- **Cost-Benefit Assessment**

Cost Modeling

RECORDING PAGE BLANK NOT FILMED

PAGE 117 INTENTIONALLY BLANK

COST MODELING STUDY APPROACH

The Space Station Cost Modeling effort was an integrated part of the total study. The Mission Model of the "User Needs and Mission Requirements" task was the basis for the Scenarios of the "Architecture/Mission Implementation Task". These Scenarios provided payload, architecture and STS data for use in Cost Modeling.

Two Cost Model computer programs were developed, one for the Space Station and one for Mission Payloads. These programs generate tabular and graphical system cost estimates. These estimates were developed at the Space Station Module level (level 4 of the WBS) and were phased through every year of the period 1985 - 2000. Cost results were fed back through the Architecture/Implementation tasks to improve Scenario outcomes.

SS COST MODELING STUDY APPROACH

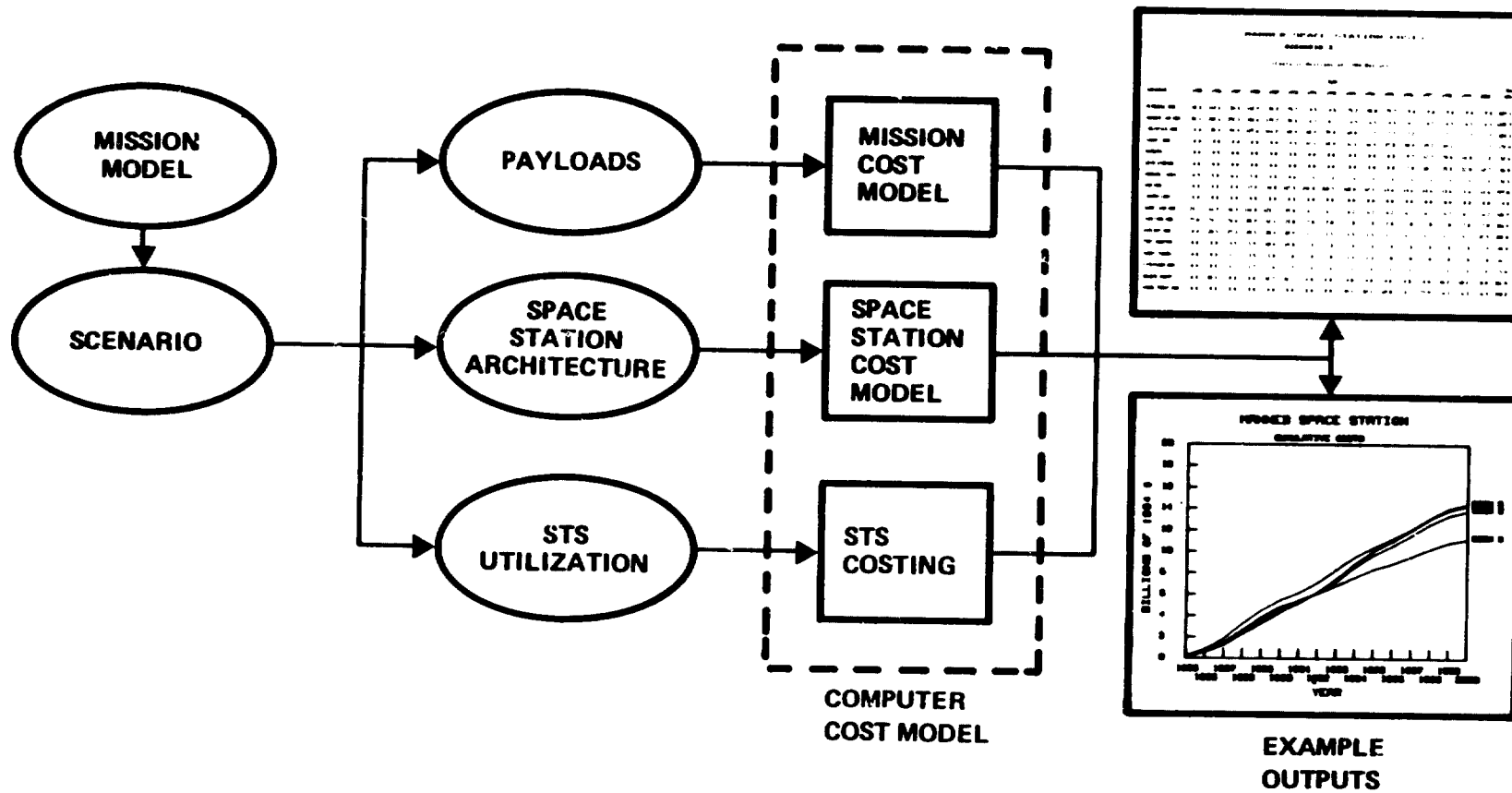

COST MODELING WAS AN INTEGRATED PART OF THE STUDY

ORIGINAL PAGE IS
OF POOR QUALITY

SPACE STATION COST MODELING

Space Station cost modeling made use of a wide range of cost analysis resources. TRW's space system cost experience was implemented through analogy, developed cost estimating relationships (CER's) and the RCA PRICE model, which includes a Platform variable that allows the assessment of man-rated space hardware.

Our Cost Benefits Analysis Review Board provided data and advice on both costs and benefits. Board participation was as follows:

- * General Research Corporation: Dr. E.N. Dodson
- * Planning Research Corporation: Mr. C. Bloomquist
- * Science Applications, Inc.: Dr. B. O'Leary

In addition, general aerospace industry experience was made use of, especially through the vehicle of the Johnson Space Center Cost Model.

The primary output of this process was a module level cost estimating methodology that generates Space Station costs as a function of weight and complexity.

SS COST MODEL COMPARISONS

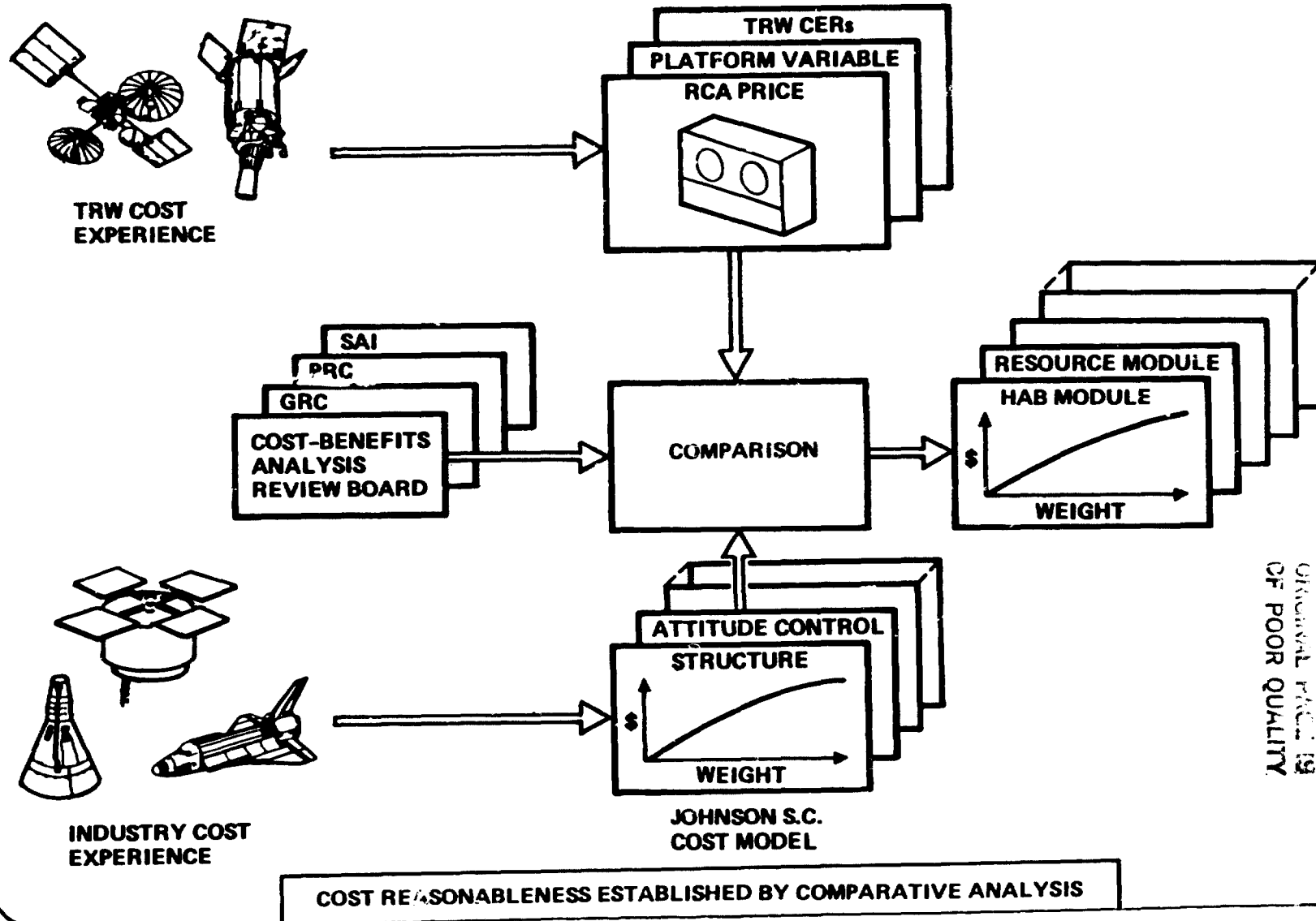

GROUND RULES AND ASSUMPTIONS

These ground rules and assumptions characterize the cost data shown in the following charts. Costs are presented in constant 1984 dollars without fee. The STS cost factor of \$86 million per flight reflects the assumption that STS operations in the 1990 time frame will have reached a steady state efficiency which yields costs similar to the current user charge. The Orbit Transfer Vehicle cost factor approximates recent experience with IUS/Centaur class OTV's.

Costs are life cycle for the period 1985 - 2000, covering DDT&E, Production and Operations and Maintenance. Learning is taken at the 90% level on most multiple procurements, depending on hardware delivery intervals.

GROUND RULES AND ASSUMPTIONS



- ALL COSTS IN 1984 DOLLARS WITHOUT FEE
- STS COST PER FLIGHT: \$86M
- CONVENTIONAL ORBIT TRANSFER VEHICLE: \$42M
- COSTS COVER 1985 - 2000
- 90% LEARNING CURVE WHERE APPROPRIATE

SPACE STATION WORK BREAKDOWN STRUCTURE

This work breakdown structure (WBS) was used to organize the cost data generated in the Space Station study. An "Evolutionary Scenario" represents all assumed space activities in the years 1985 - 2000. The Space Station portion of that scenario is contained in the Space Segment, Ground Segment, System Level Management and Integration and Space Transportation legs of the WBS. All missions and their deployment are separately accounted for. Product oriented detail has been specified to the module level within the Space and Ground Segments.

It will be seen that the study considers economic benefits to be cost savings in the mission leg of the WBS. These benefits are compared to the Space Station cost previously defined.

SPACE STATION WORK BREAKDOWN STRUCTURE

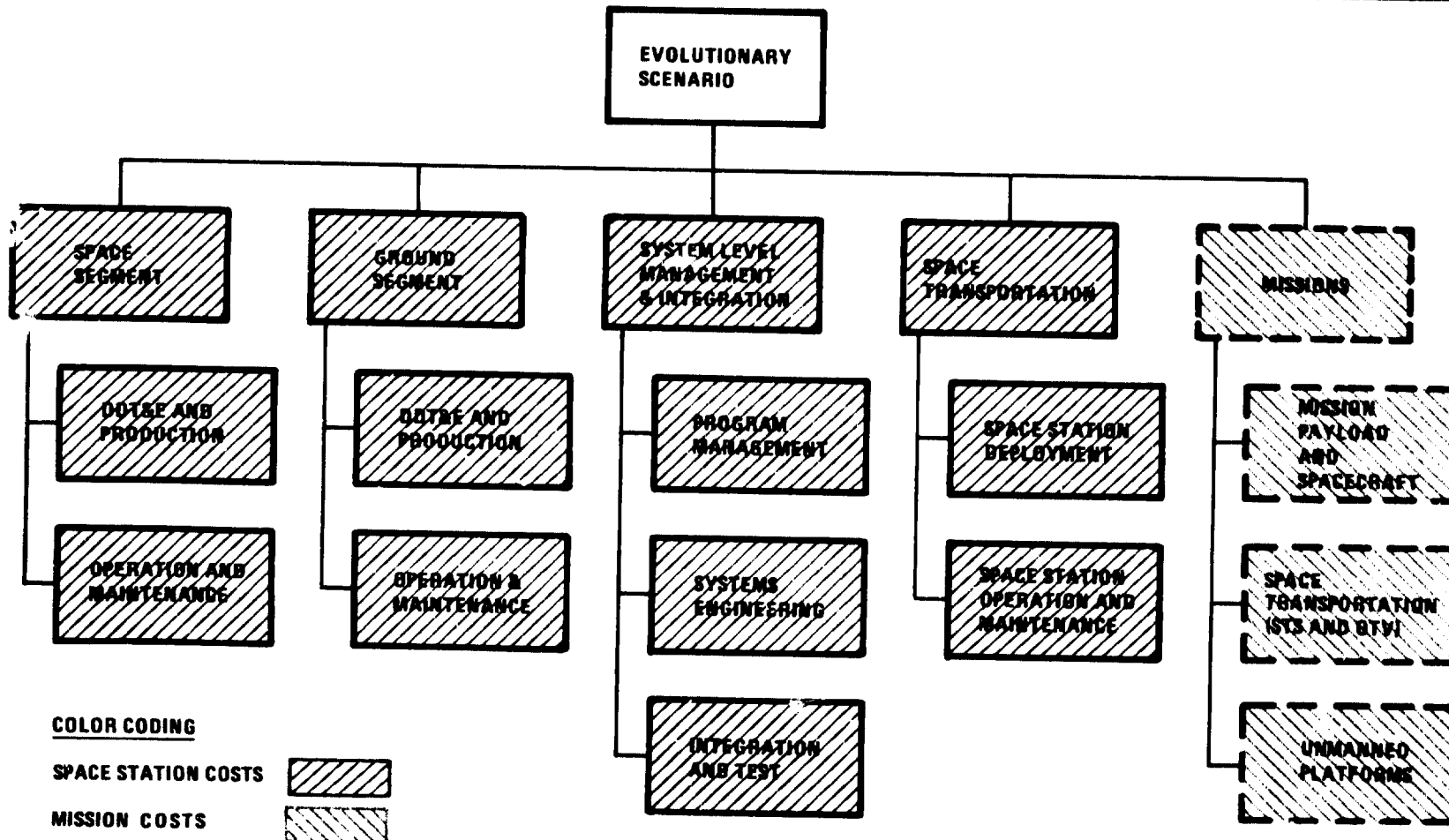

COLOR CODING

SPACE STATION COSTS



MISSION COSTS

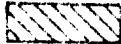

COSTS WERE DEVELOPED AT WBS LEVEL 4

ORIGINAL PAGE IS
 OF POOR QUALITY

LIFE CYCLE COST COMPARISON OF SCENARIOS (1985 - 2000)

This chart compares the total Life Cycle cost of the various scenarios. Scenario 0 (STS only) is included as a frame of reference. Scenario costs shown here are for system elements over and above those contained in Scenario 0. The three bars shown for each scenario indicate the cost by phase.

Scenario 1, the Space Platform case, is clearly the least expensive. Man is not a part of this architecture, thus man-rated development and frequent O&M STS flights are not required. However, this scenario does not deliver the benefits of the manned scenarios, as will be demonstrated.

Scenario 2 shows the cost for manned space stations in LEO and PEO. Scenario 3 eliminates the PEO Space Station and adds space platforms in PEO. Scenario 4 equates to Scenario 2 with the addition of a LEO Space Platform. Scenario 5 adds to this the establishment of an early manned capability through the use of the orbiter.

Of the manned scenarios, Scenario 3 is the least expensive. But this was obtained by eliminating the PEO Space Station. The impact on benefits is addressed in the charts that follow.

SCENARIO COST COMPARISONS BY PHASE (1985-2000)

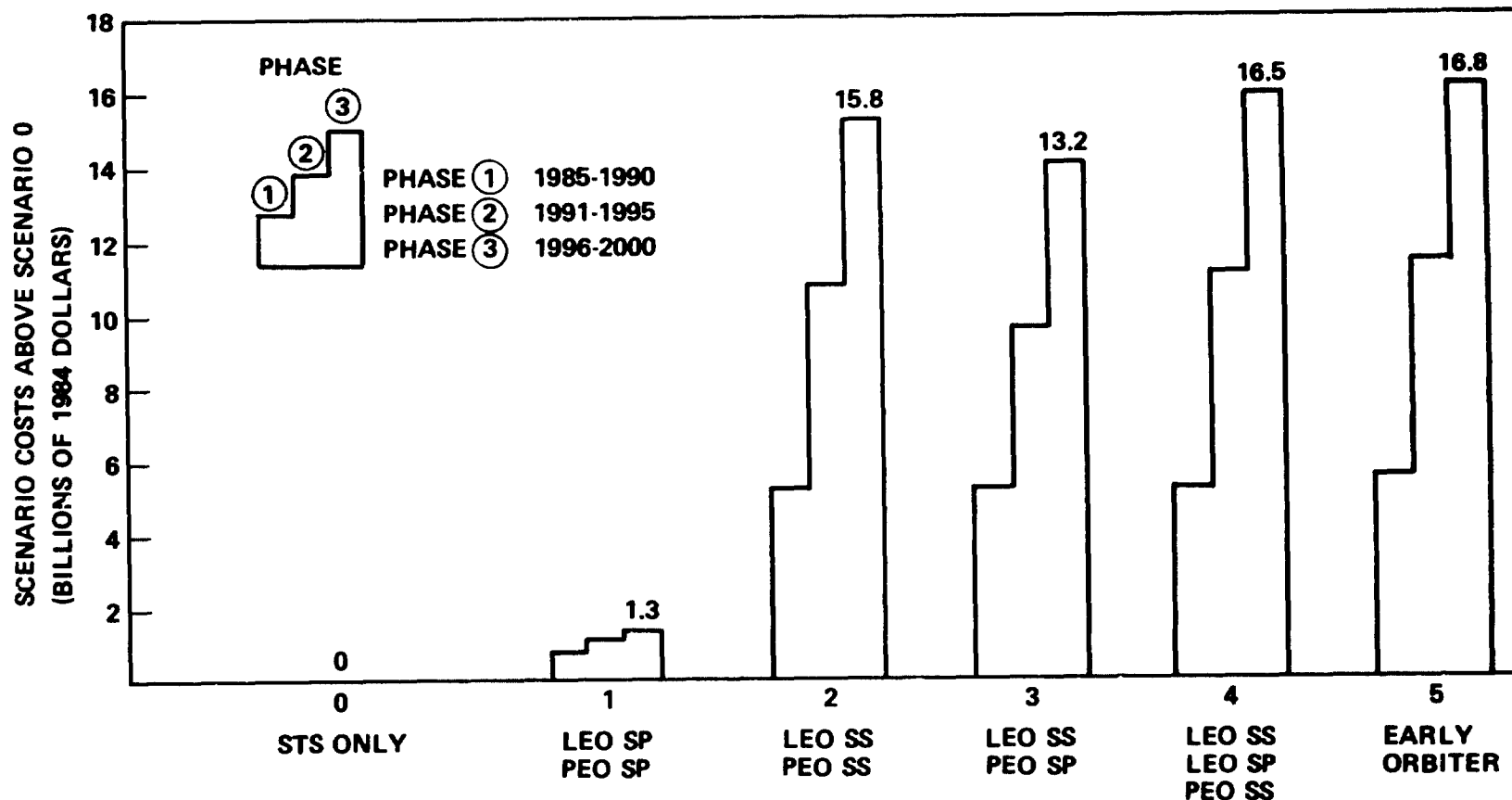

ORIGINAL PAGE IS
 OF POOR QUALITY

SCENARIO 3 IS THE LOWEST COST MANNED SPACE STATION SCENARIO STUDIED

PRECEDING PAGE BLANK NOT FILMED

Benefit Quantification

PAGE 129 INTENTIONALLY BLANK

SPACE STATION ECONOMIC BENEFITS

The addition of a Space Station to Scenario \emptyset generates a positive net benefit. Reductions in Mission Pa, load, Transportation, Free Flyer and Platform costs are greater than the cost of the Space station for all Scenarios. The functions that generate these cost reductions (benefits) are discussed in the following.

ORBIT TRANSFER. Space Station enables the establishment of an Aerobraked Returnable Orbit Transfer Vehicle. This vehicle reduces the cost of orbit transfer due to reusability and non-propulsive braking, resulting in a Mission Segment, cost savings and a Space Station benefit. The transshipment of Comsats provides another source of cost savings due to increased efficiency.

STS LOAD FACTOR. Space Station provides the opportunity to warehouse space hardware so that STS flights can be more fully loaded. This increased STS load factor reduces Mission Segment STS flights and transportation costs.

MANNED LABORATORY. Mission costs for the Manned Laboratory are saved in that it is a permanent part of the Space Station and the cost of transporting it up and down repeatedly is avoided.

SATELLITE SERVICING. The Economic benefit of the Space Station comes from the difference in cost between servicing satellites from the Space Station or from the STS.

ON-ORBIT ASSEMBLY. The availability of a manned Space Station will enable satellite assembly on orbit. This will benefit outsized missions as well as allow increased efficiency in satellite assembly and test, thereby saving mission costs.

FEWER UNMANNED PLATFORMS. For all scenarios fewer unmanned Platforms are required than for Scenario \emptyset , thus a cost savings over Scenario \emptyset .

SPACE STATION ECONOMIC BENEFITS

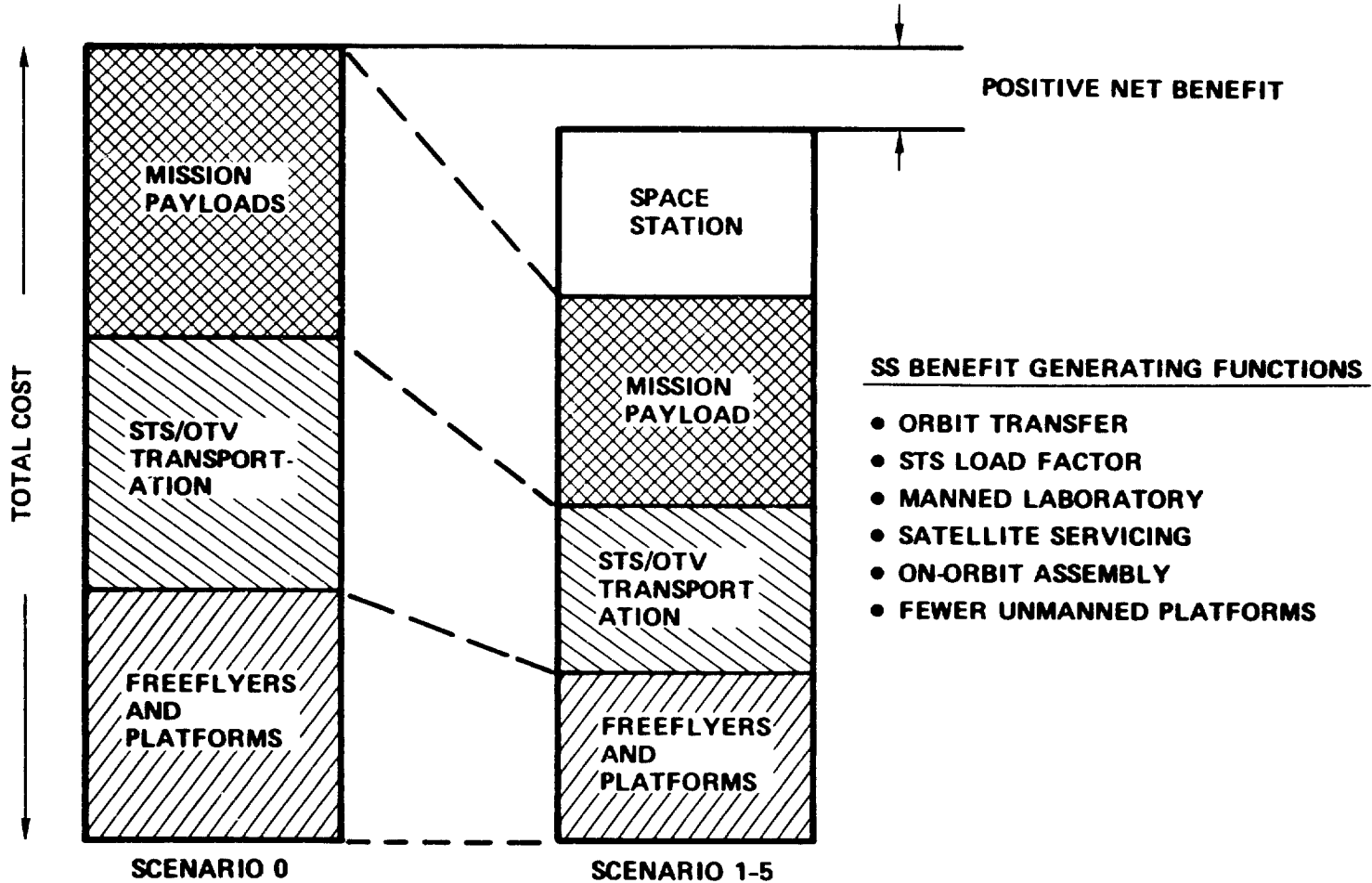

SS BENEFIT GENERATING FUNCTIONS

- ORBIT TRANSFER
- STS LOAD FACTOR
- MANNED LABORATORY
- SATELLITE SERVICING
- ON-ORBIT ASSEMBLY
- FEWER UNMANNED PLATFORMS

ORIGINAL PAGE IS
OF POOR QUALITY

SPACE STATION SCENARIOS GENERATE POSITIVE NET BENEFITS

SPACE STATION BENEFIT QUANTIFICATION

The savings indicated on the chart are due to the following:

<u>FUNCTION/MISSION</u>	<u>BASIS FOR SAVINGS</u>
ORBIT TRANSFER	
AROTV	Reusability and non-propulsive braking.
COMSAT TRANSHIPMENT	Efficient use of OTV's.
STS LOAD FACTOR	Space Station allows warehousing and handling operations. STS loadings increase 65% - 82%.
MANNED LABORATORY	Laboratory is permanent with Space Station; save on reflly costs.
FEWER UNMANNED PLATFORMS	Missions flown on Unmanned Platforms in Scenario 0 fly more economically on Space Platform or Space Station.
SATELLITE SERVICING	
GEO	SS-based AROTV makes cost effective.
LEO	Savings over STS based servicing.
REMOTE SENSING	Hardware cost reductions due to availability of servicing.
MPS	Cost savings relative to STS servicing of material processing in space.
ON-ORBIT ASSEMBLY	
ON-ORBIT AI&T	Increased efficiency in satellite AI&T. Enables construction of large satellites.
LARGE INSTRUMENTS	Avoids design drivers and intermediate stable configurations required with STS only.
MSSR	Mars Surface Sample Return. Same as for large instruments.

SPACE STATION BENEFIT QUANTIFICATION



ORBIT TRANSFER



AROTV
\$2.5B



COMSAT
TRANSSHIPMENT
\$0.8B

STS LOAD FACTOR



\$5.1B

MANNED LABORATORY

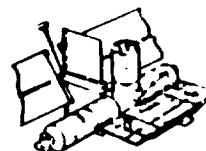

\$2.8B

FEWER UNMANNED PLATFORMS



\$1.3B

SATELLITE SERVICING

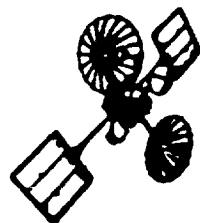

GEO
\$3.3B

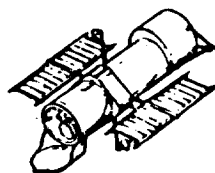

LEO
\$0.5B



REMOTE
SENSING
\$0.6B

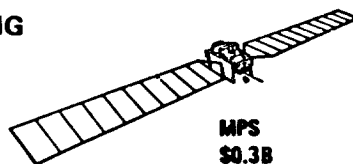

MPS
\$0.3B

ON-ORBIT ASSEMBLY

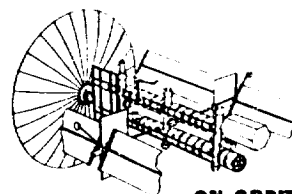

ON-ORBIT
A1&T
\$0.8B



LARGE
INSTRUMENTS
\$0.7B



MSSR
\$0.3B

(TYPICAL VALUES – BILLIONS OF 1984 DOLLARS)

ORIGINAL PAGE IS
OF POOR QUALITY

SPACE STATION INCREASES SPACE EFFICIENCY

PRECEDING PAGE BLANK NOT FILMED

Cost-Benefit Assessment

PAGE 135 INTENTIONALLY BLANK

COST BENEFIT COMPARISON

This chart compares the costs and benefits of the various scenarios in order to develop a ranking. The measures available are Net Benefits (Total Benefits less Total Costs) and Benefit-Cost Ratio (Total Benefits divided by Total Costs).

Scenario 1 ranks last by far in net benefits but first in benefit-cost ratio. This reflects a small but relatively efficient investment. It does not, however, generate the non-quantified benefits of man in space.

Scenarios 2 through 5 all share equally in the non-quantified benefits. Of these four Scenario 3 is the clear leader, showing better marks in both measures of merit. Comparing Scenarios 3 and 4 it is clear that the PEO Space Station costs more than the benefits it adds.

The results of this analysis are that Scenario 3 is preferred.

COST BENEFIT COMPARISON

SCENARIO

	UNMANNED	MANNED			
	<u>1</u>	<u>2</u>	<u>3</u>	<u>4</u>	<u>5</u>
TOTAL BENEFITS	2.0	19.5	18.4	20.2	20.2
TOTAL COSTS	<u>1.3</u>	<u>15.8</u>	<u>13.2</u>	<u>16.5</u>	<u>16.8</u>
NET BENEFITS	0.7	3.7	5.2	3.7	3.4
	SP - LEO SP - PEO	SS - LEO SS - PEO	SS - LEO SP - PEO	SS - LEO SP - LEO SS - PEO	EARLY ORBITER

(\$B-84, 1985-2000)

 SELECTED
 SCENARIO

MAXIMUM NET BENEFITS ACCRUE FROM A MANNED SPACE STATION SCENARIO

ORIGINAL PAGE IS
 OF POOR QUALITY

BENEFITS OF A MANNED SPACE STATION

Our study has shown that a Manned Space Station generates economic benefits in excess of its cost. This fact alone indicates that a Manned Space Station project should be pursued. The fact that Social and Performance benefits are also generated is a clear vote of confidence for a decision reached on the basis of financial analysis. Social and Performance benefits, while difficult to quantify with consistency, are often more important than the financial aspects of the problem.

BENEFITS OF A MANNED SPACE STATION

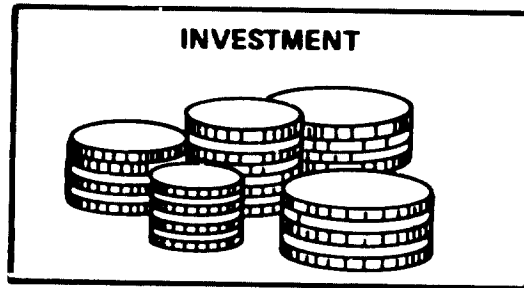

INVESTMENT

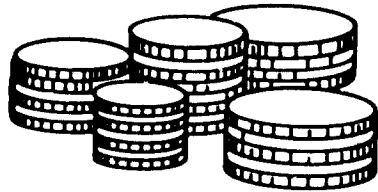

**MANNED
SPACE
STATION**

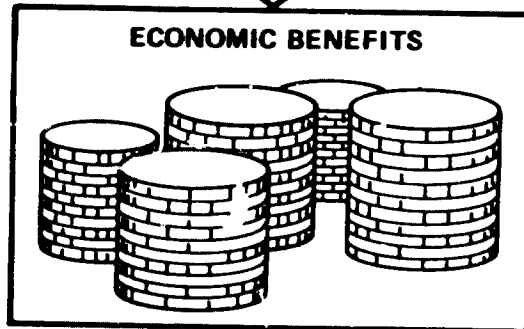
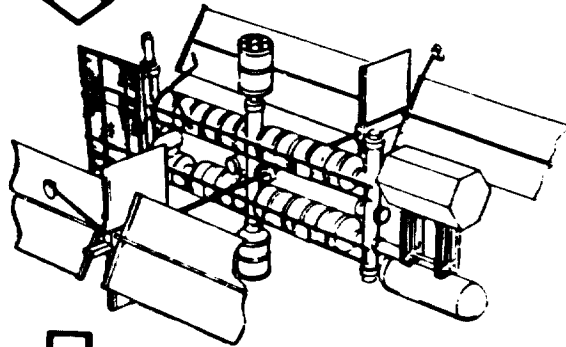

ECONOMIC BENEFITS

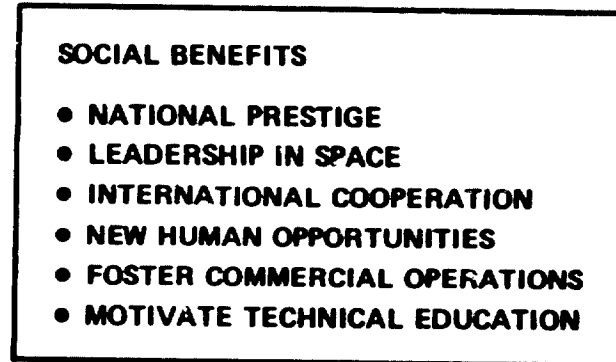
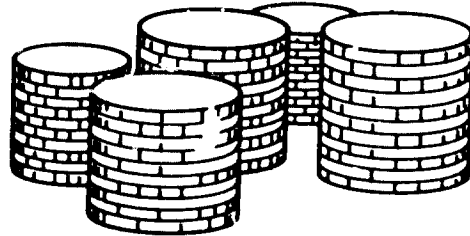

SOCIAL BENEFITS

- NATIONAL PRESTIGE
- LEADERSHIP IN SPACE
- INTERNATIONAL COOPERATION
- NEW HUMAN OPPORTUNITIES
- FOSTER COMMERCIAL OPERATIONS
- MOTIVATE TECHNICAL EDUCATION

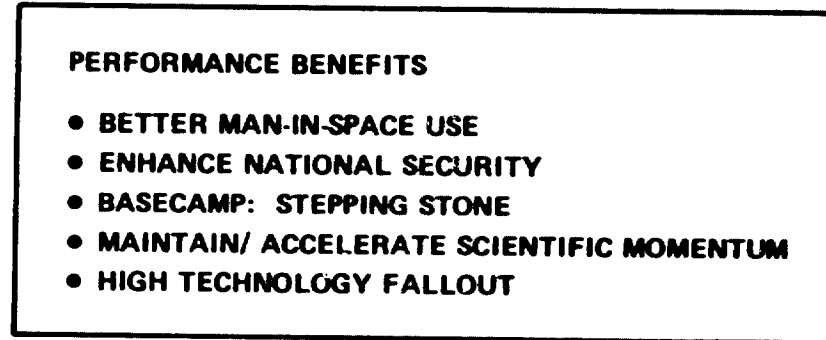
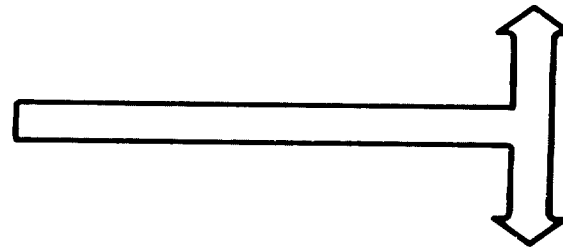

PERFORMANCE BENEFITS

- BETTER MAN-IN-SPACE USE
- ENHANCE NATIONAL SECURITY
- BASECAMP: STEPPING STONE
- MAINTAIN/ ACCELERATE SCIENTIFIC MOMENTUM
- HIGH TECHNOLOGY FALLOUT

**AN INVESTMENT IN A MANNED SPACE STATION YIELDS
MORE THAN ECONOMIC BENEFITS**

ORIGINAL PAGE IS
OF POOR QUALITY

TIME DISTRIBUTION OF BENEFITS AND COSTS

This chart lays out the distribution of costs and benefits for Scenario 3. Benefits begin to accrue in advance of the Space Station deployment as satellite programs are configured to take advantage of Space Station attributes. The benefits continue to rise through 1995 where the introduction of the AROTV provides a significant step increase in benefit production. System capability established by the year 2000 provides a steady state benefit as shown.

The cost stream reflects three peaks consistent with the initial, interim and growth deployments of the Space Station. This leads to a steady state cost which reflects the O&M cost of the station. Comparison of the steady state benefit and cost lead to a net steady state benefit in the years beyond 2000.

TIME DISTRIBUTION OF BENEFITS AND COSTS

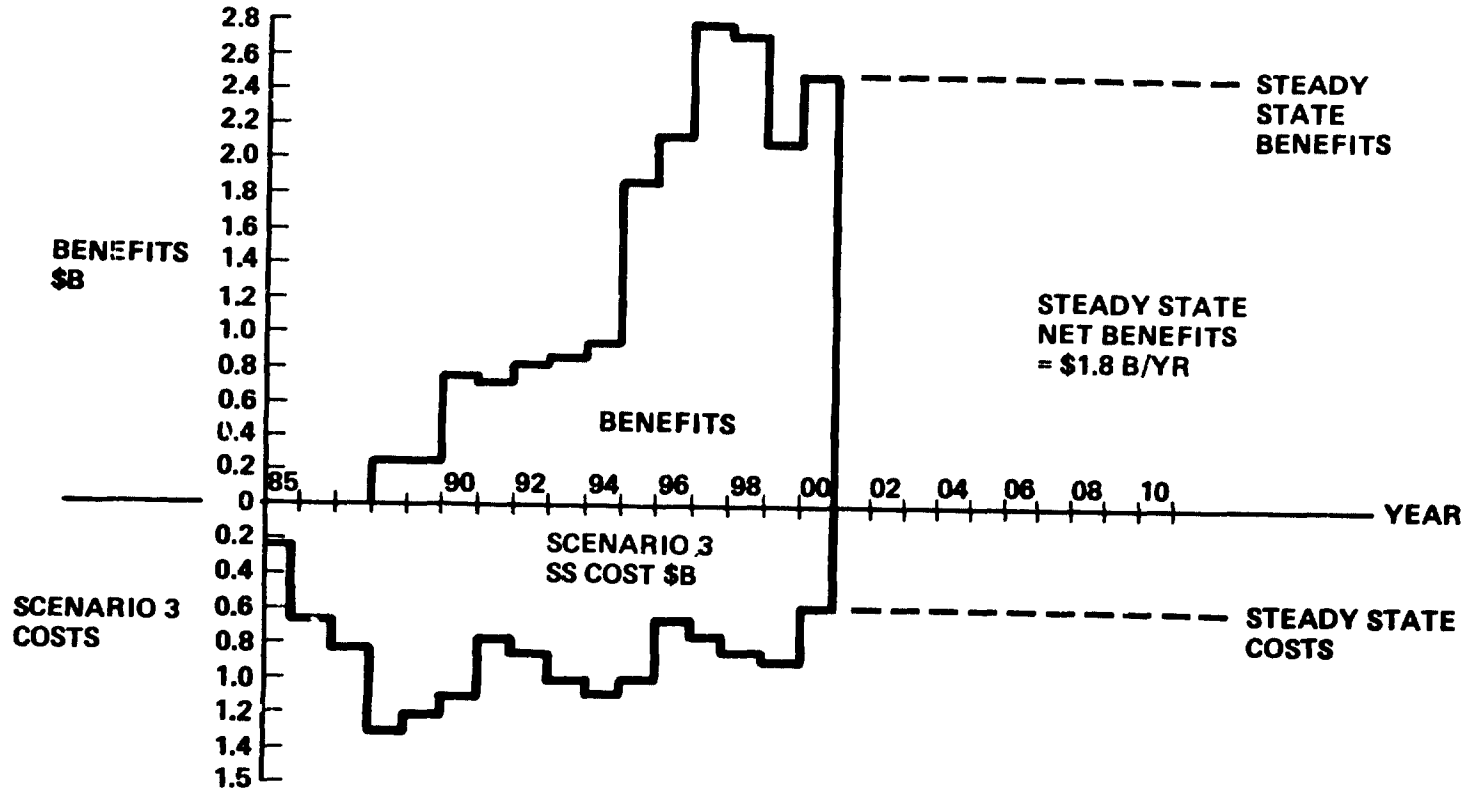

ECONOMIC BENEFITS EXCEED COSTS IN LATE 1990's

ORIGINAL PAGE IS
OF POOR QUALITY

DISTRIBUTION OF LIFE CYCLE COSTS FOR SCENARIO 3

This chart separates the \$13.2B of Scenario 3 into the major WBS elements. Half the cost goes to acquire and maintain the Space Segment, one-third provides for space transportation while the remainder provides for the ground segment and management and integration.

DISTRIBUTION OF LIFE CYCLE COSTS FOR SCENARIO 3

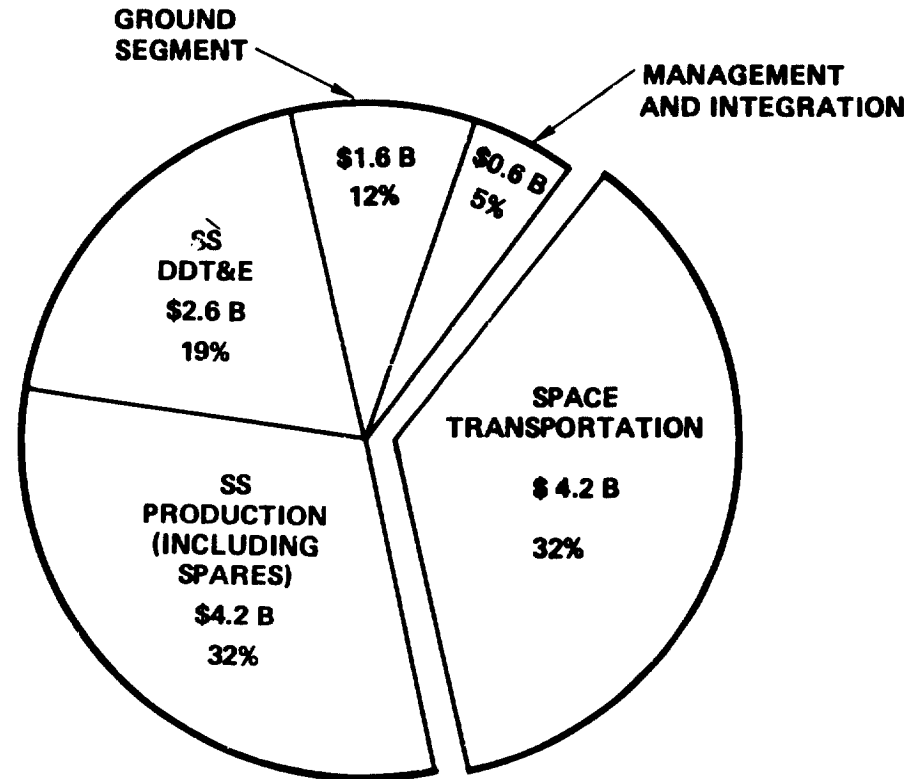

SPACE TRANSPORTATION COSTS ARE A MAJOR FACTOR

ORIGINAL PAGE IS
OF POOR QUALITY

SPACE STATION COSTS - ANNUAL AND CUMULATIVE TOTALS

This graph presents funding requirements for the Scenario 3 Space Station Program. The left scale refers to the annual data (the bars) while the right scale refers to the cumulative data (the line).

The peak funding occurs in 1988 and is \$1.3B. The three phases of Scenario 3 require funding as follows:

● Initial	1985 - 1990	\$5.4B
● Interim	1991 - 1995	4.6B
● Growth	1996 - 2000	<u>3.2B</u>
	Total	\$13.2B

SPACE STATION COSTS ANNUAL AND CUMULATIVE TOTALS SCENARIO 3



ANNUAL COSTS
 MILLIONS OF 1984 DOLLARS

CUMULATIVE COSTS
 BILLIONS OF 1984 DOLLARS

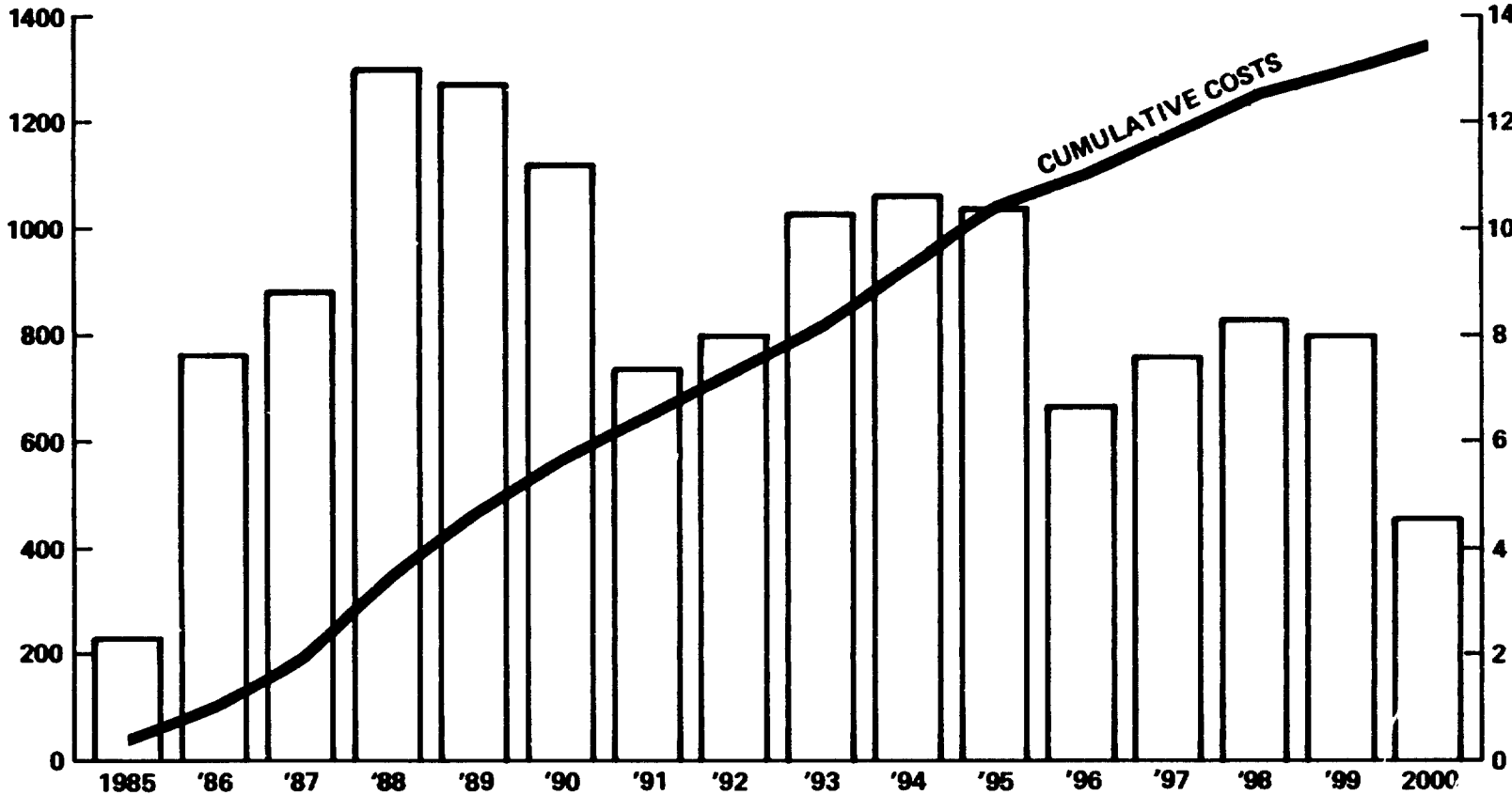

- PEAK FUNDING REQUIREMENTS LESS THAN \$1.4 B.
- LIFE CYCLE COST LESS THAN \$14 B.

ORIGINAL PAGE IS
 OF POOR QUALITY

SPACE STATION EXECUTIVE SUMMARY BRIEFING AGENDA



PRECEDING PAGE BLANK NOT FILMED

- INTRODUCTION & CONCLUSIONS
- USER NEEDS/MISSION REQUIREMENTS
- ARCHITECTURE/MISSION IMPLEMENTATION
- PROGRAM COSTS AND BENEFITS

SUMMARY AND RECOMMENDATIONS

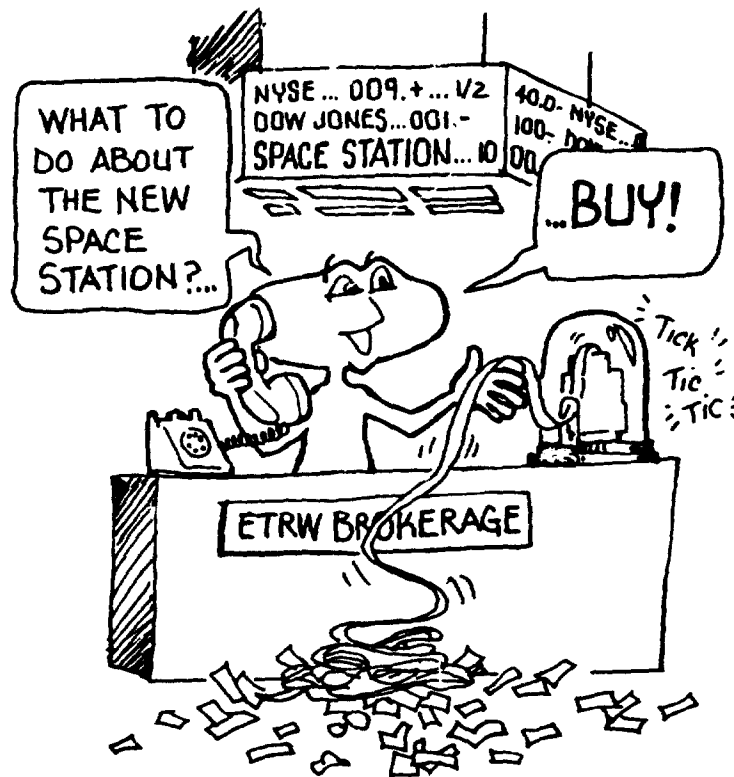

ORIGINAL PAGE IS
OF POOR QUALITY

SUMMARY OF STUDY REPORT

The vu-graph summarizes the top level conclusions of our study. A manned space station produces a significant net economic benefit over its cost, as well as providing substantial social and performance benefits. The largest space station benefits arise from the ability of the SS to warehouse parts, ORUs and fuel and thereby increase the STS load factor. Substantial other benefits are made possible by the basing of a ROTV and the servicing of GEO satellites at the SS. Therefore, TRW recommends that a manned space station be placed in a 28.5° inclination orbit in 1990. This SS can be designed to grow, to be maintained and to incorporate new technology as it becomes available. It should be augmented with unmanned space platforms at both 28.5° and polar inclinations. These platforms can and should be designed to have very high commonality with the SS resource models.

SUMMARY OF STUDY RESULTS

- **EVOLUTIONARY MANNED SS AT 28.5° INCLINATION IS RECOMMENDED**
- **SS TO BE AUGMENTED BY SPACE PLATFORMS IN BOTH 28.5° AND POLAR ORBITS**
- **RESOURCE MODULE OF SS TO HAVE HIGH COMMONALITY WITH SP**

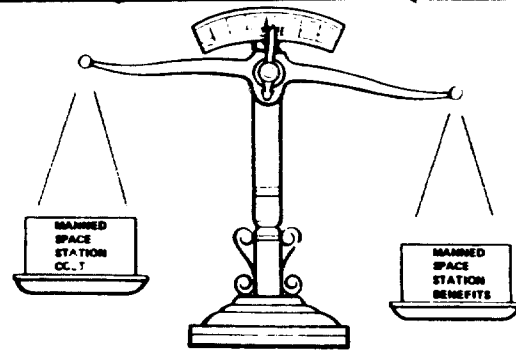
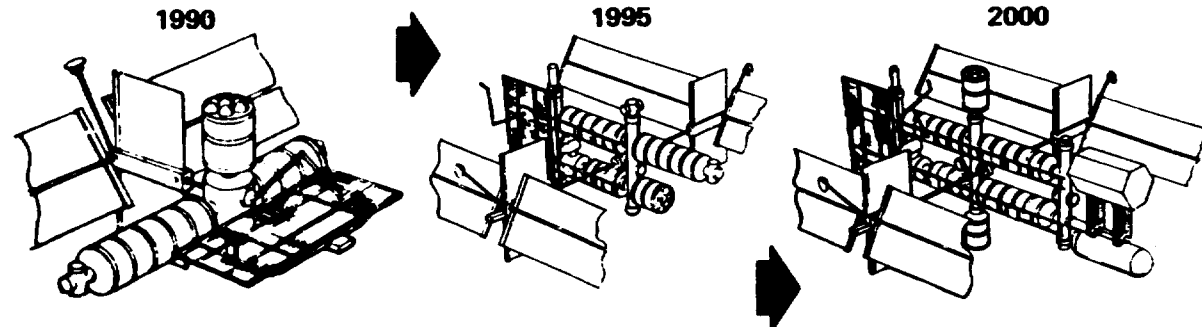

- **INITIAL COST THROUGH 1990 IS \$5.4B (1984)**
- **PEAK YEAR FUNDING IS \$1.3B (1984)**
- **STEADY STATE NET BENEFITS OF SS EXCEED O&M COSTS BY \$1.8B (1984)/YEAR BY 2000**

ORIGINAL PAGE IS
OF POOR QUALITY

- **LARGEST SS BENEFITS DERIVE FROM HIGHER STS LOAD FACTOR (65% TO 82%) ENABLED BY SS**
- **SIGNIFICANT SS BENEFITS ARISE FROM BASING OF ROTV AND SERVICING GEO SATELLITES**

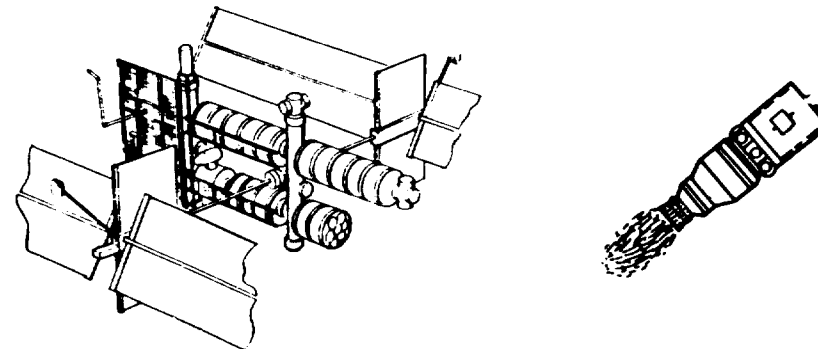

FOLLOW-ON STUDY RECOMMENDATIONS

TRW's follow-on study recommendations are outlined on the facing page. We look forward to continuing Space Station studies.

FOLLOW-ON STUDY RECOMMENDATIONS



- TRW HAS SUBMITTED A LIST OF TEN FOLLOW-ON STUDY TRADE TOPICS FOR THE PERIOD 1 MAY – 1 OCTOBER 1983. THESE ARE:
 - SP AND SS RESOURCE MODULE COMMONALITY
 - DATA MANAGEMENT SYSTEM ARCHITECTURE
 - ELECTRICAL POWER SUBSYSTEM SELECTION
 - CO-ORBITING SPACECRAFT METHODS
 - SS PLACEMENT, ALTITUDE AND SERVICING STRATEGY
 - INTEGRATED HYDROGEN/OXYGEN SYSTEMS
 - LOGISTICS AND SUPPLY OPERATIONS
 - GROUND OPERATIONS SUPPORT
 - THERMAL CONTROL APPROACHES
 - COMMUNICATIONS NEEDS
- CONTINUED NASA SS FUNDING IS VITAL TO ALLOW RETENTION OF KEY MEMBERS OF TRW SS TEAM
- CONTINUE DIALOGUE BETWEEN NASA AND TRW ON KEY TECHNOLOGY DEVELOPMENTS



SPACE STATION IS THE DOORWAY TO FUTURE SPACE EXPLORATION

We close with a reminder that, like the Wright brothers' first airplane and the first Sputnik spacecraft, a permanently manned space station in low earth orbit will open a door to the future. Beyond that threshold, somewhere in the first years of the twenty-first century, the race of human beings will become a space-faring civilization. Human operations at geosynchronous orbit will begin and ultimately become routine. Analysis and possibly processing of material samples returned from the surfaces of asteroids, moons and planets of our solar system will be carried out on the space station. The first lunar base construction missions will be assembled and launched from the space station. Finally, the thousand-year-old dream of mankind to travel to and explore the planets will begin with the in-orbit construction of a planetary excursion spacecraft on the space station.

We cannot know what benefits mankind will derive from the opening of the door to future space exploration, but that a permanently manned space station is the doorway, the threshold, the beginning there can be no doubt.

SPACE STATION IS THE DOORWAY TO FUTURE SPACE EXPLORATION

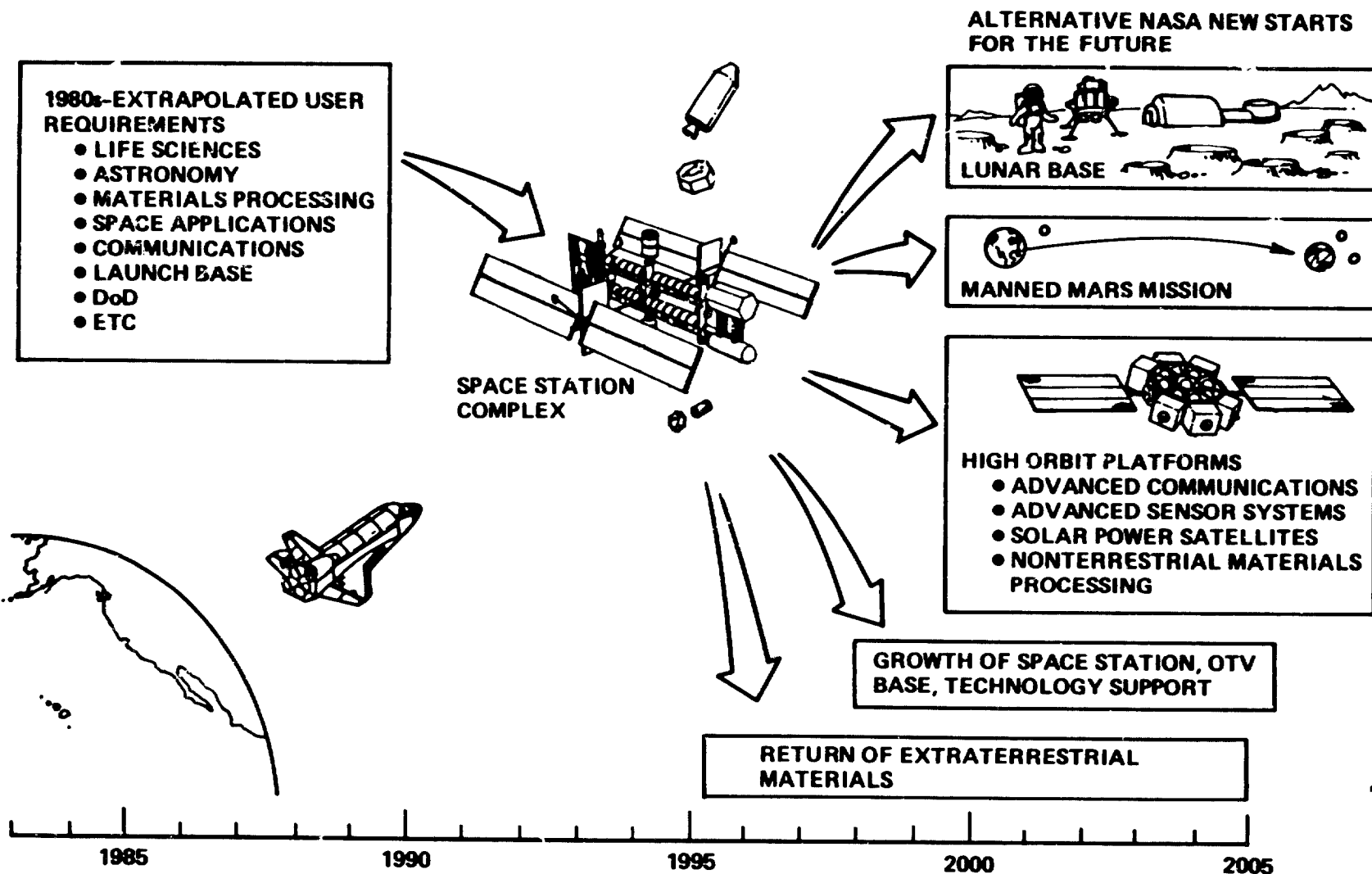

ORIGINAL PAGE IS
 OF POOR QUALITY