



August 3, 2021

The Honorable Chair and Members  
of the Hawai'i Public Utilities Commission  
Kekuanao'a Building, First Floor  
465 South King Street  
Honolulu, Hawai'i 96813

Dear Commissioners:

Subject: Docket No. 2018-0165  
Instituting a Proceeding to Investigate Integrated Grid Planning  
Hawaiian Electric Updated and Revised Inputs and Assumptions &  
Distribution DER Hosting Capacity Grid Needs

In accordance with Order No. 37730 *Directing Hawaiian Electric to File Revised Forecasts and Assumptions* issued in the subject proceeding on April 14, 2021 ("Order No. 37730"), and consistent with its Workplan Update and Stakeholder Engagement Plan filed on June 18, 2021, and Workplan Update filed on July 28, 2021, the Company<sup>1</sup> respectfully submits its updated and revised Integrated Grid Planning ("IGP") Inputs and Assumptions document and Distribution DER Hosting Capacity Grid Needs attached hereto. The associated electronic files<sup>2</sup> of the updated and revised Input and Assumption workbooks and Distribution DER Hosting Capacity Grid Needs will also be available on the Company's website. On July 22, 2021, stakeholders were emailed a preliminary copy of the workbook format and a link to the revised IGP website consistent with Order No. 37730. The Company is currently soliciting feedback on the format of the workbook and website and may make adjustments as feedback is received. However, the contents and values contained in the workbook are consistent with the attached Inputs and Assumptions document and are not expected to change.

The updated and revised Inputs and Assumptions reflects over two years of stakeholder engagement, with significant contributions from stakeholders since the Commission issued Order No. 37730 on April 14, 2021. The Company sought areas of consensus amongst stakeholders and explained the Company's position where there was disagreement.

Although there are a few remaining items that will be part of an October 1, 2021 Review Point, the Company believes the updated and revised Inputs and Assumptions attached to this

---

<sup>1</sup> Hawaiian Electric Company, Inc., Maui Electric Company, Limited, and Hawai'i Electric Light Company, Inc. are collectively referred to as "Hawaiian Electric" or the "Company".

<sup>2</sup> Electronic files are also included in support of this filing. The files are voluminous (approximately 707 MB) and therefore are being provided to both the Commission (via its One Drive) and the Consumer Advocate (DVD). A copy of these files will be saved to the Company's website: <https://www.hawaiianelectric.com/clean-energy-hawaii/integrated-grid-planning/stakeholder-engagement/key-stakeholder-documents> for access by the parties to this proceeding. In addition, copies of the DVD will be made available to any party to this proceeding. Interested parties may email [Regulatory@hawaiianelectric.com](mailto:Regulatory@hawaiianelectric.com) to request a copy.

The Honorable Chair and Members  
of the Hawai'i Public Utilities Commission  
August 3, 2021  
Page 2

letter are ripe for review and approval by the Commission as they represent a significant majority of the inputs and assumptions needed to begin preliminary analyses of Grid Needs along with a set of inputs and assumptions that can be used in work products across other interrelated dockets. Therefore, the Company respectfully requests the Commission approve the updated and revised Inputs and Assumptions.

The Company would like to express its appreciation to all stakeholders, including the Commission Staff for their thoughtful engagement, time and efforts. The Company looks forward to continuing to work with stakeholders as it finalizes the Grid Needs Assessment deliverable for the October 1, 2021 Review Point.

Sincerely,

/s/ Marc Asano

Marc Asano  
Director  
Integrated Grid Planning

Enclosures

c: Service List



**Hawaiian Electric**

**2021 Integrated Grid Planning  
Inputs and Assumptions**

**August 2021 Update**

# Table of Contents

1	INTRODUCTION.....	10
2	STAKEHOLDER ENGAGEMENT.....	14
2.1	Forecast Assumptions Working Group .....	15
2.2	2021 Stakeholder Meetings .....	17
2.3	Stakeholder Areas of Consensus.....	21
2.4	Stakeholder Areas of Disagreement .....	25
2.5	Parking Lot for Issues to Be Resolved in Future Planning Cycles .....	30
3	OVERVIEW OF THE RESOLVE AND PLEXOS MODELS .....	32
3.1	RESOLVE Capacity Expansion Model.....	32
3.2	PLEXOS Production Simulation Model.....	43
4	FORECAST ASSUMPTIONS.....	45
4.1	Load Forecast.....	45
4.1.1	Distributed Energy Resource Forecasts.....	47
4.1.2	Energy Efficiency.....	56
4.1.3	Electrification of Transportation .....	58
4.1.4	Managed Electric Vehicle Charging .....	62
4.2	Sales Forecasts.....	63
4.3	Peak Forecasts .....	69
4.4	Fuel Price Forecasts .....	73
4.5	Resource Cost Forecasts .....	77
5	RESOURCE POTENTIAL AND RENEWABLE ENERGY ZONES.....	89
5.1	NREL Solar and Wind Resource Potential Study Update.....	89
5.1.1	Solar and Wind Potential Assumption for IGP.....	93
5.2	Renewable Energy Zones .....	94





6	MODELING SCENARIOS AND SENSITIVITIES .....	106
6.1	RESOLVE Modeling Scenarios and Sensitivities.....	107
6.1.1	Scenario and Sensitivity Development Process.....	107
6.1.2	Revised Sensitivities and Scenarios .....	108
7	THERMAL GENERATING UNIT PORTFOLIOS .....	114
8	THERMAL GENERATING UNIT REMOVAL FROM SERVICE SCHEDULES .....	146
9	VARIABLE RENEWABLE, STORAGE, AND GRID SERVICE RESOURCE PORTFOLIOS .....	147
10	LOCATION-BASED FORECASTS .....	151
10.1	Stages of the Distribution Planning Process.....	151
10.2	LoadSEER Forecasting Engine .....	152
11	HOSTING CAPACITY ANALYSIS.....	155
APPENDIX A:	NOMINAL RESOURCE COST FORECASTS (2020 – 2050).....	157
APPENDIX B:	DISTRIBUTED ENERGY RESOURCE FORECASTS (2020 – 2050) .	168
APPENDIX C:	FORECAST METHODOLOGIES .....	171
1.	Underlying Forecast Methodologies.....	171
	O’ahu Underlying Forecast.....	173
	Hawai’i Underlying Forecast.....	178
	Maui Island Underlying Forecast.....	189
	Lāna’i Island Underlying Forecast.....	198
APPENDIX D:	SALES FORECASTS (2020 – 2050).....	204
APPENDIX E:	PEAK FORECASTS (2020 – 2050).....	210



# Table of Figures

Table 3.1: O’ahu Day Weights .....	33
Table 3.2: Hawai’i Island Day Weights .....	35
Table 3.3: Maui Day Weights .....	37
Table 3.4: Moloka’i Day Weights.....	39
Table 3.5: Lāna’i Day Weights .....	41
Table 4.1: Input Data Sources for Underlying Forecast.....	46
Table 4.2. Summary of assumptions used to develop DER forecast sensitivities.....	47
Table 4.3: Federal Tax Incentive Rate Schedule .....	51
Table 4.4: State Tax Incentive Rate Schedule.....	51
Table 4.5: Addressable Market for Residential Customers .....	52
Table 4.6: Addressable Market for Commercial Customers.....	52
Table 4.7: Addressable Market, Average PV System Size, and Average Storage Size for Schedule G Customers .....	53
Table 4.8: Addressable Market, Average PV System Size, and Average Storage Size for Schedule J Customers .....	53
Table 4.9: Addressable Market, Average PV System Size, and Average Storage Size for Schedule P Customers .....	53
Table 4.10: Cumulative Distributed PV Capacity (kW) .....	53
Table 4.11: Cumulative Distributed BESS Capacity (kWh).....	54
Table 4.12: Energy Efficiency Bookend Sensitivities.....	57
Table 4.13: Electric Vehicle Forecast Sensitivities .....	62
Table 4.14: O’ahu Sales Forecast.....	64
Table 4.15: Hawai’i Island Sales Forecast .....	64
Table 4.16: Maui Sales Forecast .....	64
Table 4.17: Moloka’i Sales Forecast .....	65
Table 4.18: Lāna’i Sales Forecast.....	65
Table 4.19: O’ahu Peak Forecast (MW).....	71
Table 4.20: Hawai’i Island Peak Forecast (MW) .....	71
Table 4.21: Maui Peak Forecast (MW) .....	71
Table 4.22: Moloka’i Peak Forecast (MW) .....	72
Table 4.23: Lāna’i Peak Forecast (MW) .....	72
Table 4.24: O’ahu Fuel Price Forecast .....	74
Table 4.25: Hawai’i Island Fuel Price Forecast .....	75
Table 4.26: Maui County Fuel Price Forecast .....	76
Table 4.27: Resource Cost Data Sources .....	77



Table 4.28: Federal and State ITC Schedule for PV.....	81
Table 4.29: Federal and State ITC Schedule for Onshore Wind.....	82
Table 4.30: Federal and State ITC Schedule for Offshore Wind .....	83
Table 4.31: Federal and State ITC for Distributed Wind.....	84
Table 4.32: Federal and State ITC Schedule for CSP.....	86
Table 4.33: Federal and State ITC for Geothermal .....	86
Table 5.1: First Year Available for Candidate Resources .....	89
Table 5.2 Summarized installable capacity in MW for grid-scale 1-axis tracking PV systems all scenarios; Lands with capacity factors $\geq 0.10$ .....	90
Table 5.3 Summarized installable capacity in MW for grid-scale 1-axis tracking PV systems up to 15% and 30% slope land; Input assumptions based on Ulupono input .....	90
Table 5.4 Land exclusion assumptions for PV potential scenarios .....	91
Table 5.5 Summarized installable capacity in MW for grid-scale wind systems all scenarios; Lands with Wind speeds $\geq 6.5$ m/s .....	92
Table 5.6 Summarized installable capacity in MW for grid-scale wind systems up to 15% slope land; Input assumptions based on Ulupono input .....	92
Table 5.7 Land exclusion assumptions for wind potential scenarios.....	93
Table 6.1 Original proposed sensitivities.....	108
Table 6.2: Table of Proposed Sensitivities .....	109
Table 6.3: Forecast Layer Mapping of Modeling Scenarios and Sensitivities .....	110
Table 7.1: O’ahu Minimum and Maximum Capacity for Thermal Resources .....	114
Table 7.2: O’ahu Heat Rate Coefficients for Thermal Resources.....	115
Table 7.3: O’ahu Forced Outage Rates for Thermal Resources (1 of 4).....	116
Table 7.4: O’ahu Forced Outage Rates for Thermal Resources (2 of 4).....	117
Table 7.5: O’ahu Forced Outage Rates for Thermal Resources (3 of 4).....	118
Table 7.6: O’ahu Forced Outage Rates for Thermal Resources (4 of 4).....	119
Table 7.7: O’ahu Maintenance Outage Rates for Thermal Resources (1 of 3) .....	120
Table 7.8: O’ahu Maintenance Outage Rates for Thermal Resources (2 of 3) .....	121
Table 7.9: O’ahu Maintenance Outage Rates for Thermal Resources (3 of 3) .....	122
Table 7.10: Hawai’i Island Minimum and Maximum Capacity for Thermal Resources .....	123
Table 7.11: Hawai’i Island Heat Rate Coefficients for Thermal Resources .....	124
Table 7.12: Hawai’i Island Forced Outage Rates for Thermal Resources (1 of 4) .....	124
Table 7.13: Hawai’i Island Forced Outage Rates for Thermal Resources (2 of 4) .....	125
Table 7.14: Hawai’i Island Forced Outage Rates for Thermal Resources (3 of 4) .....	126
Table 7.15: Hawai’i Island Forced Outage Rates for Thermal Resources (4 of 4) .....	127
Table 7.16: Hawai’i Island Maintenance Outage Rates for Thermal Resources (1 of 4).....	128
Table 7.17: Hawai’i Island Maintenance Outage Rates for Thermal Resources (2 of 4).....	129
Table 7.18: Hawai’i Island Maintenance Outage Rates for Thermal Resources (3 of 4).....	130
Table 7.19: Hawai’i Island Maintenance Outage Rates for Thermal Resources (4 of 4).....	131
Table 7.20: Maui Minimum and Maximum Capacity for Thermal Resources .....	132



Table 7.21: Maui Heat Rate Coefficients for Thermal Resources .....	133
Table 7.22: Maui Forced Outage Rates for Thermal Resources (1 of 3).....	134
Table 7.23: Maui Forced Outage Rates for Thermal Resources (2 of 3).....	135
Table 7.24: Maui Forced Outage Rates for Thermal Resources (3 of 3).....	136
Table 7.25: Maui Maintenance Outage Rates for Thermal Resources (1 of 3).....	137
Table 7.26: Maui Maintenance Outage Rates for Thermal Resources (2 of 3).....	138
Table 7.27: Maui Maintenance Outage Rates for Thermal Resources (3 of 3).....	139
Table 7.28: Moloka'i Minimum and Maximum Capacity for Thermal Resources.....	140
Table 7.29: Moloka'i Heat Rate Coefficients for Thermal Resources .....	140
Table 7.30: Moloka'i Forced Outage Rates for Thermal Resources.....	141
Table 7.31: Moloka'i Maintenance Outage Rates for Thermal Resources .....	142
Table 7.32: Lāna'i Minimum and Maximum Capacity for Thermal Resources .....	143
Table 7.33: Lāna'i Heat Rate Coefficients for Thermal Resources.....	143
Table 7.34: Lāna'i Forced Outage Rates for Thermal Resources .....	143
Table 7.35: Lāna'i Maintenance Outage Rates for Thermal Resources.....	144
Table 8.1: Planned Removal from Service Assumptions for O'ahu, Hawai'i Island, and Maui .....	146
Table 9.1: O'ahu Variable Renewable, Storage, and Grid Service Resources.....	147
Table 9.2: Hawai'i Island Variable Renewable, Storage, and Grid Service Resources .....	148
Table 9.3: Maui Variable Renewable, Storage, and Grid Service Resources .....	149
Table 9.4: Moloka'i Variable Renewable, Storage, and Grid Service Resources .....	150
Table 9.5: Lāna'i Variable Renewable, Storage, and Grid Service Resources .....	150
Table 11.1: Capital and O&M Costs for Resource Options (Paired Grid-Scale PV, Standalone Grid-Scale PV, Commercial-Scale PV) .....	157
Table 11.2: Capital and O&M Costs for Resource Options (Residential PV, Onshore Wind, Distributed Wind).....	158
Table 11.3: Capital and O&M Costs for Resource Options (Offshore Wind North, Offshore Wind East, Offshore Wind South).....	160
Table 11.4: Capital and O&M Costs for Resource Options (Grid-Scale Storage, Pumped Storage Hydro).....	161
Table 11.5: Capital and O&M Costs for Resource Options (Paired Grid-Scale Storage (2hrs), Paired Grid-Scale Storage (4hrs)).....	162
Table 11.6: Capital and O&M Costs for Resource Options (Paired Grid-Scale Storage (6hrs), Paired Grid-Scale Storage (8hrs), DER Aggregator).....	163
Table 11.7: Capital and O&M Costs for Resource Options (Synchronous Condenser, Geothermal, Municipal Solid Waste).....	164
Table 11.8: Capital and O&M Costs for Resource Options (Biomass) .....	165
Table 11.9: Capital and O&M Costs for Resource Options (Concentrated Solar, Combined Cycle) ..	166
Table 11.10: Capital and O&M Costs for Resource Options (Combustion Turbine, Internal Combustion Engine) .....	167
Table 11.11: Cumulative Distributed PV Capacity (kW) .....	168
Table 11.12: Cumulative Distributed BESS Capacity (kWh).....	170



Table 11.13: O’ahu Residential Customer Econometric Sales Model Variables .....	174
Table 11.14: O’ahu Commercial Customer Econometric Sales Model Variables .....	175
Table 11.15: Hawai’i Residential Econometric Sales Model Variables .....	180
Table 11.16: Hawai’i Small and Medium Commercial Customer Econometric Sales Model Variables .....	183
Table 11.17: Hawai’i Large Power Customer Econometric Sales Model Variables .....	186
Table 11.18: Maui Residential Customer Econometric Sales Model Variables .....	190
Table 11.19: Maui Small and Medium Commercial Customer Econometric Sales Model Variables .....	192
Table 11.20: Maui Large Power Customer Econometric Sales Model Variables .....	195
Table 11.21: Lāna’i Residential Customer Econometric Sales Model Variables .....	198
Table 11.22: Moloka’i Residential Customer Econometric Sales Model Variables.....	201
Table 11.23: O’ahu Sales Forecast.....	204
Table 11.24: Hawai’i Island Sales Forecast .....	206
Table 11.25: Maui Sales Forecast .....	207
Table 11.26: Moloka’i Sales Forecast .....	208
Table 11.27: Lāna’i Sales Forecast .....	209
Table 11.28: O’ahu Peak Forecast (MW).....	210
Table 11.29: Hawai’i Island Peak Forecast (MW) .....	212
Table 11.30: Maui Peak Forecast (MW) .....	213
Table 11.31: Moloka’i Peak Forecast (MW) .....	214
Table 11.32: Lāna’i Peak Forecast (MW) .....	215
Figure 2-1 – FAWG Meetings.....	15
Figure 2-2: O’ahu High EV Bookend Sensitivity Comparison .....	26
Figure 2-3: Maui High EV Bookend Sensitivity Comparison .....	26
Figure 2-4: Hawai’i Island High EV Bookend Sensitivity Comparison .....	27
Figure 2-5: Fuel prices with estimated import / export adder .....	29
Figure 2-6: Historic LSFO Purchase Volume .....	30
Figure 3-1: O’ahu Net Load Duration Curve Comparison .....	34
Figure 3-2: O’ahu Net Load Distribution Comparison .....	35
Figure 3-3: Hawai’i Island Net Load Duration Curve Comparison .....	36
Figure 3-4: Hawai’i Island Net Load Distribution Comparison.....	37
Figure 3-5: Maui Net Load Duration Curve Comparison .....	38
Figure 3-6: Maui Net Load Distribution Comparison.....	39
Figure 3-7: Moloka’i Net Load Duration Curve Comparison.....	40
Figure 3-8: Moloka’i Net Load Distribution Comparison .....	41
Figure 3-9: Lāna’i Net Load Duration Curve Comparison .....	42
Figure 3-10: Lāna’i Net Load Distribution Comparison.....	43
Figure 4-1: O’ahu DER Bookend Sensitivities .....	56



Figure 4-2: O’ahu Energy Efficiency Annual Sales Forecast Impact Sensitivities ..... 58

Figure 4-3: Revised Light Duty Electric Vehicle Charging Profiles..... 61

Figure 4-4: O’ahu Electric Vehicle Annual Sales Forecast Sensitivities ..... 62

Figure 4-5: Average Managed EV Charging Profile for O’ahu..... 63

Figure 4-6: O’ahu Sales Forecast Bookend Sensitivities ..... 67

Figure 5-1: Transmission Renewable Energy Zone Planning Process ..... 95

Figure 5-2: Transmission Renewable Energy Zone Study Procedures ..... 96

Figure 5-3: Grid-scale PV and Wind MW Potential on O’ahu Island..... 97

Figure 5-4: Adjusted Utility Scale PV MW Potential on O’ahu Island ..... 98

Figure 5-5: Group of REZs for O’ahu Island ..... 99

Figure 5-6: Adjusted Utility Scale PV MW Potential on Maui Island ..... 100

Figure 5-7: Maui Island Transmission REZ – Option 1 ..... 101

Figure 5-8: Maui Island Transmission REZ – Option 2 ..... 102

Figure 5-9: Adjusted Utility Scale PV MW Potential on Hawai’i Island ..... 103

Figure 5-10: Hawai’i Island Transmission REZ – Option 1..... 104

Figure 5-11: Hawai’i Island Transmission REZ – Option 2 ..... 105

Figure 10-1 : Stages of the Distribution Planning Process ..... 152

Figure 10-2: LoadSEER in Distribution Planning Process ..... 153

Figure 10-3: LoadSEER Layers..... 154





# 1 Introduction

On January 19, 2021, the Company filed its first Review Point on the Inputs and Assumptions (“I&A”) (“I&A Review Point”), for Hawaiian Electric’s 2021 Integrated Grid Planning process which included stakeholder input incorporated over the previous two years of stakeholder engagement. In March 2021, Hawaiian Electric issued an updated Input and Assumptions document reflecting stakeholder feedback that was summarized in the [IGP Stakeholder Feedback Summary, March 2021](#).

This August 2021 Update (“August I&A Update”) provides an overview of how the inputs and assumptions are used by the RESOLVE and PLEXOS models to develop grid needs and reflects the most recent feedback received from stakeholders throughout the IGP process to date consistent with the Commission’s Order No. 37730 described more fully below. In particular, the August I&A Update implements the directives of Order No. 37730 which includes: the Technical Advisory Panel (“TAP”) “has thoroughly reviewed the revised Draft IGP Inputs and Assumptions, stakeholders have had ample opportunity to provide corrective feedback, and Hawaiian Electric has either incorporated that feedback, or clearly explains why it did not.”<sup>11</sup>

The inputs and assumptions described herein include:

- Sales forecast by forecast layer for the underlying load, distributed energy resource, energy efficiency, and electrification of transportation layers
- Fuel price forecast
- Resource cost forecast
- Scenarios and sensitivities
- Additional assumptions used to characterize the existing and planned resource portfolio

Notably, certain key inputs and assumptions had broad agreement amongst stakeholders, including: general consensus on sales and peak forecasts, inclusion of warming trends based on Forecast Assumptions Working Group feedback, stakeholder comments acknowledging that the EV forecast and treatment of managed and unmanaged charging are reasonable, and modeling scenarios and sensitivities that were vetted through the Stakeholder Council and the TAP.

In addition, the TAP had previously reviewed the regulating reserve definitions, in which the Company incorporated additional analyses to examine different time durations and confidence intervals. The TAP also indicated the prudence of the Company’s proposal to transition to a reliability planning criteria that uses a new

---

<sup>11</sup> Order No. 37730 at 53-54.





methodology that evaluates all hours of the year and chronological operations of the grid (Energy Reserve Margin).

On April 14, 2021, the Commission issued Order No. 37730 Directing Hawaiian Electric to File Revised Forecasts and Assumptions (“Review Point Guidance”), to address certain inputs and assumptions that warranted further discussion with stakeholders. Since April 2021, the Company has been engaged with stakeholders to address the remaining items highlighted in the Review Point Guidance. The 10 key areas include:<sup>2</sup>

- (1) adjust resource/technology cost projections;
- (2) adjust fuel price forecasts;
- (3) adjust and better explain its DER and load forecasts;
- (4) provide qualitative and quantitative summaries of LoadSEER findings and disaggregated location-specific load forecasts;
- (5) provide the results of the probabilistic DER hosting capacity analysis from the Synergi circuit models;
- (6) demonstrate how the probabilistic forecasts developed with LoadSEER will inform the different reference case load forecast scenarios to be established using the "bookends" approach;
- (7) develop a retirement schedule for the baseline forecast;
- (8) further develop and clearly explain its modeling sensitivities;
- (9) better explain and analytically support its grid services and planning criteria; and
- (10) work with AEG to develop modeling inputs for energy efficiency.

Section 2 of this document describes the approximately 17 stakeholder meetings held since the issuance of the Review Point Guidance, including a summary of areas of consensus reached to modify the I&A consistent with the Review Point Guidance, and areas where stakeholders may disagree with the Company’s decision on certain inputs or assumptions. In total, the Company and stakeholders have logged over 34 hours of engagement since April 2021, with deep and detailed engagement from the Stakeholder Council, TAP, and STWG. In addition to the Commission Staff, other parties to this docket have significantly contributed, including, the Consumer Advocate, Ulupono, Life of the Land, Blue Planet Foundation (“Blue Planet”), DER Parties, and Progression Hawaii Offshore Wind. Along with the many formal meetings, subsequent follow up discussions have taken place, email correspondence to exchange data and information, which in sum, has shaped the revised I&A.

As noted in the Company’s updated workplans filed on June 18, 2021, and July 28, 2021 in this docket, some items cannot be completed until certain inputs and assumptions are finalized or otherwise require more time to develop. Specifically, the summaries of LoadSEER findings and disaggregated location-specific load forecasts (item 4, above), demonstration of how the probabilistic forecasts developed with LoadSEER will inform the different reference case load forecast

---

<sup>2</sup> Review Point Guidance at pages 51-52.



scenarios (item 5), analytical support for grid service and planning criteria (item 9), and development of energy efficiency supply curves with AEG (item 10). These remaining items are expected to be filed along with the Grid Needs Assessment deliverable Review Point by October 1, 2021.

Regarding LoadSEER location specific forecasts, in order to meet the October 1<sup>st</sup> deadline, the Company will use the current high and low bookend forecasts described in this document, which have been vetted through stakeholders, to develop the location specific forecasts. Modifications to any of the forecasts submitted as part of this Input and Assumptions update may require more time to re-run LoadSEER models and subsequent analyses.

Regarding the planning criteria, the Company will continue to engage the TAP and seek their independent review on the reasonableness of the long-range planning criteria for IGP purposes. Long-range reliability planning criteria may be applied at a more coarse level than analyses used to evaluate short-term reliability needs. The Company has already started this process, with the filing of the TAP's independent review on June 1, 2021 of modeling methods, which included a review of the IGP modeling framework and tools, allowing RESOLVE to optimize energy storage paired with solar, the recommended approach to support the energy reserve margin planning criteria, and the provision of "virtual" inertia from inverter based resources. As discussed at the June 23, 2021 Stakeholder Council meeting and subsequent smaller group meetings, the Company is currently transitioning the TAP leadership to a new Chair and reviewing the core membership of the TAP in response to the Review Point Guidance to add a TAP member. Once a new TAP chair is selected, the TAP will resume its planned activities. The Company is actively working with stakeholders, including Commission Staff on modifications to the TAP.

As the Commission noted in its Review Point Guidance, "there is inherent uncertainty in predicting the future, so it is impossible to determine the accuracy of a forecast result a priori."<sup>3</sup> Accordingly, and consistent with Commission guidance, the Company has strived to employ best practices, focus on stakeholder engagement, develop appropriate scenarios and sensitivities, and demonstrate forecasting rigor and reasonableness through transparent justification of their forecast to stakeholders and the Commission.<sup>4</sup>

The Company believes that the stakeholder engagement activities since April 2021 have substantially improved the IGP inputs and assumptions. As such, the IGP process is now well positioned to identify near-term and long-term grid needs portfolios that will provide a range of options to assist the Company, stakeholders, and Commission to make informed decisions on solution sourcing. The inputs and assumptions are designed to have the support of stakeholders that have been involved in the process as a substantial majority of the changes described herein are responsive to stakeholders and the Review Point Guidance. The Company

---

<sup>3</sup> Order No. 37730 at 54-55.

<sup>4</sup> Id.



looks forward to Commission acceptance of the forecasts, inputs and assumptions so that the modeling work to identify grid needs can start in earnest. Through Stakeholder Council and working group discussions, stakeholders are also eager to move forward with the next phases of the IGP process and start the process of modeling analysis.



## 2 Stakeholder Engagement

The IGP stakeholder engagement plan has been a significant undertaking for the Company as well as stakeholders with a proactive engagement approach to attain:

- Constructive and long-term working relationships with stakeholders;
- Stronger communication and transparency between parties, regulators, and the utility;
- Building of common ground on key issues and common vocabulary;
- More efficient and streamlined regulatory proceedings related to grid planning;
- Stakeholder feedback to incorporate into the development of planning inputs, assumptions, methodologies, and processes; and
- Transparency, predictability, and buy-in from different interested parties.

As the Company's December 2018 IGP Workplan<sup>5</sup> described, seven working groups would be assembled in 2019 to address key areas of development that would shape the inputs, assumptions, and methods to integrate resource, transmission, distribution planning to produce a stakeholder driven long-term resource plan that meets the needs of customers and state policy objectives. The seven working groups each had a clear set of objectives and deliverables as outlined in the Workplan and working groups. Those objectives and deliverables were re-affirmed at the November 7, 2019 stakeholder council meeting<sup>6</sup> in response to the Commission's guidance provided on November 4, 2019 through Order No. 36725 in Docket No. 2018-0165. On November 5, 2020 the Commission issued Order No. 37419 in Docket No. 2018-0165, Providing Guidance, in it the Commission reiterated the importance of stakeholder input to the planning process, which included proactively seeking stakeholder feedback, and allowing stakeholders the time and resources to provide meaningful feedback, and incorporating feedback in the IGP deliverables.

Subsequently, on January 19, 2021, the Company filed its Inputs and Assumptions with the Commission, a culmination of nearly two years of working group, Stakeholder Council, and TAP meetings.

On March 4, 2021, the Company filed a Stakeholder Feedback Summary document summarizing the key themes from the various stakeholder groups, including areas where the Company directly incorporated stakeholder feedback in the areas of transparency, resource costs and options, renewable resource potential, high and low bookend sensitivities, and generating unit retirements.

---

<sup>5</sup> Integrated Grid Planning Workplan filed in Docket No. 2018-0165 on December 14, 2018 ("Workplan").

<sup>6</sup> See,

[https://www.hawaiianelectric.com/documents/clean\\_energy\\_hawaii/integrated\\_grid\\_planning/stakeholder\\_engagement/stakeholder\\_council/20191107\\_sc\\_meeting\\_presentation\\_materials.pdf](https://www.hawaiianelectric.com/documents/clean_energy_hawaii/integrated_grid_planning/stakeholder_engagement/stakeholder_council/20191107_sc_meeting_presentation_materials.pdf)



## 2.1 FORECAST ASSUMPTIONS WORKING GROUP

The Forecast Assumptions Working Group (“FAWG”) was stood up in March 2019 with the primary role to provide strategic inputs and feedback on assumptions and methodologies used for load forecast development and results.

The FAWG supported development of forecast assumptions and sensitivities as part of the pre-IGP planning cycle activity and provides strategic inputs and feedback on assumptions and methodologies used for load forecast development and results. The FAWG structure and level of engagement was one of the most proactive in the industry to-date combining industry experts for best practice validation and resident Hawaii experts representing their respective contributions on economic outlook, energy efficiency potentials and program roadmaps, and transportation electrification. This was in addition to engaging a broad set of stakeholders in the FAWG and with the Stakeholder Council and TAP.

Year	2019												
	Month	Jan	Feb	Mar	Apr	May	Jun	Jul	Aug	Sep	Oct	Nov	Dec
Forecast Assumptions Working Group (FAWG)			◆			◆		◆	◆				

Year	2020												
	Month	Jan	Feb	Mar	Apr	May	Jun	Jul	Aug	Sep	Oct	Nov	Dec
Forecast Assumptions Working Group (FAWG)	◆		◆						◆				

Figure 2-1 – FAWG Meetings

The FAWG engaged 18 different organizations and 26 different individuals and various docket intervenors during the stakeholder engagement process. The FAWG met with stakeholders eight times (including a two-day meeting in May 2019) before finalizing the forecast. The forecast assumptions<sup>7</sup> informed by FAWG stakeholder input was presented to the FAWG on January 29, 2020 and included the Applied Energy Group (“AEG”) Energy Efficiency Potential Study,<sup>8</sup> Distributed

<sup>7</sup> FAWG draft IGP Inputs and Assumptions:

[https://www.hawaiianelectric.com/documents/clean\\_energy\\_hawaii/integrated\\_grid\\_planning/stakeholder\\_engagement/working\\_groups/forecast\\_assumptions/20200925\\_draft\\_IGP\\_inputs\\_and\\_assumptions.pdf](https://www.hawaiianelectric.com/documents/clean_energy_hawaii/integrated_grid_planning/stakeholder_engagement/working_groups/forecast_assumptions/20200925_draft_IGP_inputs_and_assumptions.pdf)

<sup>8</sup> AEG Hawaii Statewide Market Potential Study (PDF):

[https://www.hawaiianelectric.com/documents/clean\\_energy\\_hawaii/integrated\\_grid\\_planning/stakeholder\\_engagement/working\\_groups/forecast\\_assumptions/20200129\\_wg\\_fa\\_hawaii\\_market\\_potential\\_study\\_draft\\_results.pdf](https://www.hawaiianelectric.com/documents/clean_energy_hawaii/integrated_grid_planning/stakeholder_engagement/working_groups/forecast_assumptions/20200129_wg_fa_hawaii_market_potential_study_draft_results.pdf)



Energy Resource forecasts,<sup>9</sup> Electrification of Transportation Forecast,<sup>10</sup> and a Behind the Meter (BTM) Solar Photovoltaic (PV) and Battery Energy Storage System (BESS) forecast.<sup>11</sup> The load forecast with these layers was presented to the FAWG on March 9, 2020.<sup>12</sup> Additionally, resource related inputs were shared with the FAWG including the Fuel Forecast<sup>13</sup> and Resource Cost forecast.<sup>14</sup> The FAWG reconvened on August 31, 2020 to review updates to the forecast based on near-term economic impacts forecasted by UHERO<sup>15</sup> as a result of the COVID-19 pandemic and effect on the forecasted sales and peak forecast.<sup>16</sup>

- 
- <sup>9</sup> IGP DER Forecast - Oahu (EXCEL) - [https://www.hawaiianelectric.com/documents/clean\\_energy\\_hawaii/integrated\\_grid\\_planning/stakeholder\\_engagement/working\\_groups/forecast\\_assumptions/HE\\_DER\\_forecast\\_IGP.xlsx](https://www.hawaiianelectric.com/documents/clean_energy_hawaii/integrated_grid_planning/stakeholder_engagement/working_groups/forecast_assumptions/HE_DER_forecast_IGP.xlsx); IGP DER Forecast - Hawaii (EXCEL) - [https://www.hawaiianelectric.com/documents/clean\\_energy\\_hawaii/integrated\\_grid\\_planning/stakeholder\\_engagement/working\\_groups/forecast\\_assumptions/HL\\_DER\\_forecast\\_IGP.xlsx](https://www.hawaiianelectric.com/documents/clean_energy_hawaii/integrated_grid_planning/stakeholder_engagement/working_groups/forecast_assumptions/HL_DER_forecast_IGP.xlsx); and IGP DER Forecast - Maui (EXCEL) - [https://www.hawaiianelectric.com/documents/clean\\_energy\\_hawaii/integrated\\_grid\\_planning/stakeholder\\_engagement/working\\_groups/forecast\\_assumptions/ME\\_DER\\_forecast\\_IGP.xlsx](https://www.hawaiianelectric.com/documents/clean_energy_hawaii/integrated_grid_planning/stakeholder_engagement/working_groups/forecast_assumptions/ME_DER_forecast_IGP.xlsx)
- <sup>10</sup> IGP EoT Forecast (EXCEL) - [https://www.hawaiianelectric.com/documents/clean\\_energy\\_hawaii/integrated\\_grid\\_planning/stakeholder\\_engagement/working\\_groups/forecast\\_assumptions/EoT\\_forecast\\_IGP.xlsx](https://www.hawaiianelectric.com/documents/clean_energy_hawaii/integrated_grid_planning/stakeholder_engagement/working_groups/forecast_assumptions/EoT_forecast_IGP.xlsx)
- <sup>11</sup> IGP BTM PV\_BESS Cost Forecast (EXCEL) - [https://www.hawaiianelectric.com/documents/clean\\_energy\\_hawaii/integrated\\_grid\\_planning/stakeholder\\_engagement/working\\_groups/forecast\\_assumptions/BTM\\_PV\\_and\\_paired\\_BESS\\_cost\\_forecast\\_IGP.xlsx](https://www.hawaiianelectric.com/documents/clean_energy_hawaii/integrated_grid_planning/stakeholder_engagement/working_groups/forecast_assumptions/BTM_PV_and_paired_BESS_cost_forecast_IGP.xlsx)
- <sup>12</sup> March 9, 2020 forecast presentation ([https://www.hawaiianelectric.com/documents/clean\\_energy\\_hawaii/integrated\\_grid\\_planning/stakeholder\\_engagement/working\\_groups/forecast\\_assumptions/20200309\\_wg\\_fa\\_meeting\\_presentation\\_materials.pdf](https://www.hawaiianelectric.com/documents/clean_energy_hawaii/integrated_grid_planning/stakeholder_engagement/working_groups/forecast_assumptions/20200309_wg_fa_meeting_presentation_materials.pdf)) and Forecasts by layer: Hawai'i Island (EXCEL) - [https://www.hawaiianelectric.com/documents/clean\\_energy\\_hawaii/integrated\\_grid\\_planning/stakeholder\\_engagement/working\\_groups/forecast\\_assumptions/hawaii\\_island\\_IGP\\_forecast\\_by\\_layer.xlsx](https://www.hawaiianelectric.com/documents/clean_energy_hawaii/integrated_grid_planning/stakeholder_engagement/working_groups/forecast_assumptions/hawaii_island_IGP_forecast_by_layer.xlsx); Maui, Moloka'i, and Lana'i (EXCEL) - [https://www.hawaiianelectric.com/documents/clean\\_energy\\_hawaii/integrated\\_grid\\_planning/stakeholder\\_engagement/working\\_groups/forecast\\_assumptions/MECO\\_IGP\\_forecast\\_by\\_layer.xlsx](https://www.hawaiianelectric.com/documents/clean_energy_hawaii/integrated_grid_planning/stakeholder_engagement/working_groups/forecast_assumptions/MECO_IGP_forecast_by_layer.xlsx); and O'ahu (EXCEL) - [https://www.hawaiianelectric.com/documents/clean\\_energy\\_hawaii/integrated\\_grid\\_planning/stakeholder\\_engagement/working\\_groups/forecast\\_assumptions/oahu\\_IGP\\_forecast\\_by\\_layer.xlsx](https://www.hawaiianelectric.com/documents/clean_energy_hawaii/integrated_grid_planning/stakeholder_engagement/working_groups/forecast_assumptions/oahu_IGP_forecast_by_layer.xlsx)
- <sup>13</sup> IGP 2020 Fuels Forecast (EXCEL) [https://www.hawaiianelectric.com/documents/clean\\_energy\\_hawaii/integrated\\_grid\\_planning/stakeholder\\_engagement/working\\_groups/solution\\_evaluation\\_and\\_optimization/20200420\\_wg\\_seo\\_igp\\_2020\\_fuels\\_forecast.xlsx](https://www.hawaiianelectric.com/documents/clean_energy_hawaii/integrated_grid_planning/stakeholder_engagement/working_groups/solution_evaluation_and_optimization/20200420_wg_seo_igp_2020_fuels_forecast.xlsx)
- <sup>14</sup> Resource Cost Summary (Updated September 7, 2020) (EXCEL) [https://www.hawaiianelectric.com/documents/clean\\_energy\\_hawaii/integrated\\_grid\\_planning/stakeholder\\_engagement/working\\_groups/solution\\_evaluation\\_and\\_optimization/20200717\\_wg\\_seo\\_resource\\_cost\\_forecast.xlsx](https://www.hawaiianelectric.com/documents/clean_energy_hawaii/integrated_grid_planning/stakeholder_engagement/working_groups/solution_evaluation_and_optimization/20200717_wg_seo_resource_cost_forecast.xlsx)
- <sup>15</sup> UHERO Presentation (PDF) - [https://www.hawaiianelectric.com/documents/clean\\_energy\\_hawaii/integrated\\_grid\\_planning/stakeholder\\_engagement/working\\_groups/forecast\\_assumptions/20200831\\_wg\\_fa\\_meeting\\_presentation\\_materials\\_UHERO.pdf](https://www.hawaiianelectric.com/documents/clean_energy_hawaii/integrated_grid_planning/stakeholder_engagement/working_groups/forecast_assumptions/20200831_wg_fa_meeting_presentation_materials_UHERO.pdf)
- <sup>16</sup> August 31, 2020 Forecast Assumptions Presentation: [https://www.hawaiianelectric.com/documents/clean\\_energy\\_hawaii/integrated\\_grid\\_planning/stakeholder\\_engagement/working\\_groups/forecast\\_assumptions/20200831\\_wg\\_fa\\_meeting\\_presentation\\_materials\\_HECO.pdf](https://www.hawaiianelectric.com/documents/clean_energy_hawaii/integrated_grid_planning/stakeholder_engagement/working_groups/forecast_assumptions/20200831_wg_fa_meeting_presentation_materials_HECO.pdf); and notes including stakeholder feedback and questions: [https://www.hawaiianelectric.com/documents/clean\\_energy\\_hawaii/integrated\\_grid\\_planning/stakeholder\\_engagement/working\\_groups/forecast\\_assumptions/20200831\\_wg\\_fa\\_meeting\\_summary\\_notes.pdf](https://www.hawaiianelectric.com/documents/clean_energy_hawaii/integrated_grid_planning/stakeholder_engagement/working_groups/forecast_assumptions/20200831_wg_fa_meeting_summary_notes.pdf) Hawai'i Sales and Peak Forecast (EXCEL) - [https://www.hawaiianelectric.com/documents/clean\\_energy\\_hawaii/integrated\\_grid\\_planning/stakeholder\\_engagement/working\\_groups/forecast\\_assumptions/hawaii\\_sales\\_and\\_peak\\_FAWG.xlsx](https://www.hawaiianelectric.com/documents/clean_energy_hawaii/integrated_grid_planning/stakeholder_engagement/working_groups/forecast_assumptions/hawaii_sales_and_peak_FAWG.xlsx); O'ahu Sales and Peak Forecast (EXCEL) - [https://www.hawaiianelectric.com/documents/clean\\_energy\\_hawaii/integrated\\_grid\\_planning/stakeholder\\_engagement/working\\_groups/forecast\\_assumptions/oahu\\_sales\\_and\\_peak\\_FAWG.xlsx](https://www.hawaiianelectric.com/documents/clean_energy_hawaii/integrated_grid_planning/stakeholder_engagement/working_groups/forecast_assumptions/oahu_sales_and_peak_FAWG.xlsx); Maui, Moloka'i, Lana'i Sales and Peak Forecast (EXCEL) -



The Company summarized and submitted much of the forecast and planning input information to the Commission on July 2, 2020 in response to the Commission's June 8, 2020 information request.<sup>17</sup>

The TAP's independent review of the Company's I&A Review Point filed on January 19, 2021 indicated general agreement with the Company's forecast development and methodologies. However, the TAP recommended several improvements, which the Company has addressed as described in this document:

- Hawaiian Electric should consider testing the sensitivity of models and resulting portfolios by running bookend scenarios that utilize the cumulative potential high and low load forecasts for each layer.
- Hawaiian Electric should ensure that subsequent modeling tasks include sensitivities for time-of-use flexibility and/or random variation in the daily load profiles of DER and EV loads, rather than using a static load profile across modeling tasks.
- Hawaiian Electric should consider using a wider range of future energy efficiency and EV adoption rates due to the high uncertainty, especially beyond year 10. The TAP noted that proposed retirement of thermal units might be impacted by this uncertainty

---

## 2.2 2021 STAKEHOLDER MEETINGS

The Company executed its stakeholder engagement plan<sup>18</sup> to meaningfully seek and incorporate stakeholder feedback through a number of different avenues. The Company appreciates the additional feedback and input from the Commission, TAP, and stakeholders subsequent to the Review Point Guidance. The Company held several meetings with stakeholders to listen and seek consensus on addressing the Remaining Items and provide clarity or further explanation on certain topics. The Stakeholder Working Group ("STWG") meeting materials and meeting notes referenced below are posted on the Company's website and may be accessed at: <https://www.hawaiianelectric.com/clean-energy-hawaii/integrated-grid-planning/stakeholder-engagement/working-groups/stakeholder-technical>. A summary of the Company's stakeholder engagement efforts included:

- On April 27, 2021, the Company convened a working group meeting to discuss the four modeling methods proposed by Ulupono Initiative

---

[https://www.hawaiianelectric.com/documents/clean\\_energy\\_hawaii/integrated\\_grid\\_planning/stakeholder\\_engagement/working\\_groups/forecast\\_assumptions/maui\\_sales\\_and\\_peak\\_FAWG.xlsx](https://www.hawaiianelectric.com/documents/clean_energy_hawaii/integrated_grid_planning/stakeholder_engagement/working_groups/forecast_assumptions/maui_sales_and_peak_FAWG.xlsx)

<sup>17</sup> See Docket No. 2018-0165.

<sup>18</sup> Hawaiian Electric Updated Timeline and Stakeholder Engagement Plan filed on June 18, 2021 in Docket No. 2018-0165.



(“Ulupono”).<sup>19</sup> Through robust stakeholder discussion on the issues, including a presentation by Ulupono, the Company came to a consensus agreement with Ulupono and other stakeholders on recommendations to address the methods proposed by Ulupono.

- On May 25, 2021, the Company met with the TAP to discuss the recommendations resulting from the April 27, 2021 meeting. The TAP subsequently filed their independent review on June 1, 2021, which generally concurred with the modeling method recommendations.
- On May 20, 2021, the Company officially stood up the STWG to streamline and consolidate the previous working group structure.<sup>20</sup> The STWG will be called upon as the Company advances through the next couple of phases of the IGP process, including responding to the Review Point Guidance, input on the upcoming grid needs assessment step, and other work products for which the Company seeks stakeholder feedback.
  - Four working group agendas were sent out to working group members laying out objectives, key questions, topics to discuss, and expected deliverables intended to address the Review Point Guidance. The Company also sought comments from stakeholders on agenda items and called on stakeholders to present on any topic of interest. No comments were received on the agenda and two stakeholders offered to present regarding DER forecasts and electric vehicles.
- On June 2, 2021 the Company convened the first STWG meeting to discuss the purpose and objective of each model being used in the grid needs assessment phase, RESOLVE day weight and day sample methodology, the TAP recommendations based on their review of the Ulupono modeling methods and planning criteria recommendations, DER forecasts, and bookend scenarios.
- On June 4, 2021 the Company participated in a PUC technical conference facilitated by Rocky Mountain Institute and discussed with stakeholders four key areas: energy efficiency, resource and fuel cost forecasts, DER and Load forecasts, and planning criteria. The technical conference led to foundational understanding of the Company’s and different stakeholders’ perspectives on certain topics, all of which would subsequently be discussed in more detail to reach consensus through the STWG meetings.
- On May 20, June 1, July 2, and July 16, 2021, the Company met with Applied Energy Group, 2050 Partners, and Hawai’i Energy to discuss the data needed to model energy efficiency on a comparable basis to other supply side options. The State of Hawai’i energy efficiency potential study

---

<sup>19</sup> Review Point Guidance at pages 37-39.

<sup>20</sup> Combines the Forecast Assumptions, Competitive Procurement, Distribution Planning, Grid Services, and Solution Evaluation and Optimization Working Groups. The Standardized Contracts Working Group has completed its work for its specific task. The Resilience Working Group will continue as a separate working group.





would need to be updated to model energy efficiency on the supply side; however, the current study represents 85-90% of the work that would be needed to develop the supply curves.

- Applied Energy Group, 2050 Partners, and Hawai'i Energy noted that this was not part of their current scope of work and funding would be needed to develop the specific modeling inputs.
- The Company worked with AEG to refine the scope of work, schedule, and budget to develop energy efficiency supply curves. On July 28, 2021, the Company filed a letter in this docket updating the Commission on the status of this work, including the scope and schedule to develop energy efficiency supply curves.
- On May 27, 2021, the Company and Ulupono met to discuss the fuel price and resource cost forecasts.
  - For the fuel price forecasts, comparisons between the FGE and EIA forecasts were shared. In discussing the merits of both forecasts, one suggested approach was to use the EIA reference as a high forecast and the FGE forecast as the low forecast if there was a wide enough spread between the two forecasts. There was general agreement that the EIA high forecast was not reasonable. However, based on additional analysis, Ulupono currently recommends using the Reference, High Oil Price and Low Oil Price forecasts from the EIA Annual Energy Outlook. Ulupono found that actual oil prices often reach the edges of EIA's range despite a significantly wide gap between the base and high forecast.
  - The Company provided the historical record of FGE forecasts and EIA forecasts to compare their long-term outlook performance against actuals.
  - For the resource cost forecasts, comparisons between the IHS based and NREL ATB based forecasts were shared. It was noted that the near term levelized costs for PV-storage was higher than recent procurements. The Company and Ulupono agreed to reconcile the forecasts by aligning the near-term forecast in real dollars to actual projects (i.e., Stage 1 and 2 solar paired with storage projects), then allow the forecast trend to determine the future costs according to the NREL ATB cost trends.
- On June 17, 2021, the Company convened the second meeting of the STWG to further explore issues raised in the Review Point Guidance in a collaborative fashion with stakeholders. More specifically, the STWG continued discussion regarding updated DER forecasts, including assumptions for best estimates of the tariff and program values for DER, EE and EoT. The STWG also conducted a deep dive into the LoadSEER and Synergi models including further disaggregation of forecasts by location and rate class and how LoadSEER is used to inform DER forecasts; discussion of EV managed and unmanaged charging assumptions, including



a presentation by Blue Planet regarding legislative updates on EVs in Hawaii and how other jurisdictions account for EVs in their integrated grid planning; discussion of hourly charging profiles for managed charging and associated assumptions; and discussion of efforts to finalize the inputs and assumptions on bookend sensitivities.

- On June 18 and June 23, 2021, the Company met with the Stakeholder Council to review key inputs and assumptions, including the resource and fuel forecasts, planning assumptions surrounding generator deactivations, modeling scenarios and sensitivities, and updates to the NREL solar and wind potential study. Ulupono also provided a presentation of their own modeling for plans on O'ahu that would minimize the use of agricultural land. The Stakeholder Council sought clarification on the inputs and assumptions discussed.
  - There was robust discussion regarding the availability of Department of Defense/Federal lands for renewable generation development. Stakeholders noted that the availability of Federal lands are at the discretion of the Government and, if available, are provided on a highest and best use policy. The cost of the land is likely to be high.<sup>21</sup> Other stakeholders noted that the solar potential assumptions are overly optimistic based on experience working with land owners and communities.
  - At the conclusion of the Stakeholder Council meetings regarding the inputs and assumptions, the Company committed to continuing to work closely with Ulupono, Blue Planet Foundation, DER Parties, among others that are members of the Stakeholder Council and actively engaged in the working group process to review the inputs and assumptions.
- On July 9, 2021, the Company met with a smaller group of stakeholders with a keen interest in the bookend assumptions. The Company updated stakeholders on preliminary updated forecast layers and development of high and low forecasts for EE, PV, and EV based on the feedback received at the June 17, 2021 STWG meeting.
- On July 14, 2021, the Company convened a third STWG meeting to review the updated DER layer forecasts, a review of the inputs for each scenario and sensitivity, a review of generating unit deactivation or retirement assumptions, and a review of the minimum inertia assumption in RESOLVE initially discussed at the April 27, 2021 working group meeting.
- On July 16, 2021, the Company convened a fourth STWG meeting to review the resource cost and fuel cost projections raised in the Review Point Guidance and at the June 4 technical conference, updated NREL Resource Potential scenarios consistent with the feedback provided by Ulupono, and

---

<sup>21</sup> See June 23, 2021 Stakeholder Council Meeting notes at pages 4-5. (Available at, [https://www.hawaiianelectric.com/documents/clean\\_energy\\_hawaii/integrated\\_grid\\_planning/stakeholder\\_engagement/stakeholder\\_council/20210623\\_sc\\_meeting\\_summary\\_notes.pdf](https://www.hawaiianelectric.com/documents/clean_energy_hawaii/integrated_grid_planning/stakeholder_engagement/stakeholder_council/20210623_sc_meeting_summary_notes.pdf))



a review of the transmission needs analysis methodology to determine the cost and upgrades needed to develop renewable energy zones.

- On July 27, 2021, the Company held follow up discussions with Blue Planet, among others, regarding the appropriate high EV forecast for low density vehicles to use. The details of those discussions are provided in the following section on areas of disagreement.
- On July 29, 2021, the Company continued discussions with interested stakeholders on the concept of import/export parity and how future fuel prices could be affected by the closure of the local refineries. An agreement was reached between the Company and stakeholders, which is more fully described in the following sections related to stakeholder areas of consensus and disagreement.

---

## 2.3 STAKEHOLDER AREAS OF CONSENSUS

The Company worked in a collaborative fashion with stakeholders to address the Review Point Guidance. Through the engagement process the Company sought areas of consensus with stakeholders on the various issues. The following summarizes stakeholder feedback that was directly incorporated into the revised Inputs and Assumptions. Further details in each of these areas are described in specific sections throughout this document.

### *Resource and Technology Cost Projections*

- Calibrate resource and technology cost projects establishing near-term pricing on recent renewable projects using long-term trends based on NREL ATB.
  - Recent projects used in the calibration include, Stage 1 and 2 solar paired with BESS projects, West Loch Solar, Na Pua Makani Wind farm.
  - Resource cost projections do not include land and interconnection costs; however, pricing of recent projects used to calibrate the resource cost forecasts are assumed to contain land and interconnection costs as part of their PPA terms – the company does not have insight into what portion of the PPA price is attributed to interconnection or land costs. However, to help mitigate this issue, using the PPA pricing terms was applied consistently across all resource cost projections.
- Update cost projections with the recently released 2021 NREL ATB costs
- Add a pump storage hydro resource cost projection using the 2021 NREL ATB and studies cited therein



### *Fuel Price Forecasts*

- Switch from FGE Brent fuel forecast to a 2021 EIA reference fuel forecast as the base assumption
- Add a 2021 EIA low fuel price forecast; however, currently there are no sensitivities planned to use the low fuel price forecast
- Add a 2021 EIA high fuel price forecast, recognizing there is disagreement in the validity of EIA's high scenario. However, the Company and stakeholders do agree that the EIA high fuel price forecast should not be used as the base fuel assumption but that it is useful to evaluate a potential worst case fuel price and its impact on the resource plan

### *DER and Load Forecasts*

- Develop bookends (i.e., a high and low) for each technology layer (EE, EV, DER)
- The EE forecasts will utilize data from the State of Hawaii Market Potential Study<sup>22</sup>
  - Base: Business as usual plus codes and standards. This forecast will remain unchanged;
  - Low: Business as usual only;
  - High: Achievable high plus codes and standards forecast.
- The base electric vehicle forecast will remain unchanged. Blue Planet suggested using a 100% zero emission vehicle by 2045 forecast for the high EV forecast and to incorporate assumptions on the light duty vehicle forecast from the Transcending Oil Report and/or a Blue Planet generated forecast based on last 5 years registered vehicle counts. The Company will use the Transcending Oil Report's EV forecast for the high EV bookend. As explained below, Blue Planet expressed a preference for their forecast over the Transcending Oil report's forecast..
- The unmanaged EV Charging Profiles will be updated based on Hawaii specific data from the Company's DC fast charging network and a case study conducted through deployment of EnelX's Level 2 chargers in Hawaii.
- The EV managed charging system profiles have also been updated. Commission Staff raised during a STWG meeting that the managed profiles appeared fairly flat, expecting more load shifted to the daytime. Upon further review, the Company's consultant found that their model should have shifted more load to the daytime. The models were re-run and resulted in new managed EV charging shapes with more load shifted to the daytime.
- The Company modified the base customer solar and battery storage forecast to include updated system cost projections, tax credit assumptions and future DER program export rates based on the DER docket proceeding. In the case of Oahu and Maui, additional changes included increasing the addressable market by including NEM customers for a

<sup>22</sup> Available at, <https://puc.hawaii.gov/wp-content/uploads/2021/02/Hawaii-2020-Market-Potential-Study-Final-Report.pdf>



limited time window, including EDRP and long-term upfront incentives for grid services program participation.

- The Company developed a high customer solar and battery energy storage forecast by adjusting the following adoption drivers: adding a long-term upfront incentive based on the DER docket proceeding, adding NEM customers back to the addressable market pool, extending federal tax credits, increasing addressable market (i.e., from 2-4 multi-unit dwellings to 2-49 multi-unit dwellings, commercial expansion of Rate Schedule P customers to 100% of customers), and assuming lower DER system costs.
- Re-purposed the previous base or market forecast based on self-consumption with updated system cost and tax credit assumptions to be the part of the low DER forecast.
- Addition of a time-of-use (“TOU”) layer that represents non-DER and EV customer participation

#### *LoadSEER Findings and Forecasts for Bookends*

- LoadSEER used to develop circuit-level forecasts consisting of new loads/demand and DER.
- LoadSEER is currently used on O’ahu to inform the Hosting Capacity Analysis.
- Company confirmed bookend Corporate forecasts will be used to develop location- based forecasts at the circuit level, and analyzed to determine how the High-DER and Low-DER forecasts impact grid needs.

#### *Hosting Capacity Analysis*

- Company currently undergoing Hosting Capacity Analysis with results included in this report.
- Analysis is done to determine if distribution circuits are able to accommodate the 5-year forecasted DER (based on Corporate forecast).

#### *Retirement Schedules*

- Proposed starting point planning assumptions for when units would no longer be dispatched (or deactivated or retired).
- High fuel sensitivity will be run, and allow RESOLVE to make economic-driven retirement decisions
- Addition of updated capital and operations and maintenance costs to upkeep O’ahu generating units for the foreseeable future.

#### *Modeling Sensitivities*

- Clarified modeling scenarios and sensitivities and associated inputs
- Added a high fuel sensitivity



- Stakeholders suggested that the bookend scenarios should be based on the lowest and highest possible demand. The resulting resource portfolios would inform, for example, whether the resource mix changes dramatically between bookends. If the same types of resources are selected, then perhaps we do not need to focus so much time on individual layers, e.g., increased EV uptake.
- Added similar DER Freeze cases for the other customer forecast layers to be used to approximate valuation of programs. These sensitivities can be conducted as part of the solution sourcing process to design programs.

### *Energy Efficiency*

- Incorporate energy efficiency as a supply-side resource. The Company will work with AEG to develop the appropriate supply curves, leveraging the State of Hawaii Market Potential Study.

### *NREL Resource Potential and Renewable Energy Zone*

- Use the updated solar and wind potential based on input from Ulupono. This includes allowing solar development on up to 30% sloped land and exclusion of Federal Department of Defense land based on stakeholder discussions.
- Additional sensitivity using a lower solar potential based on limited land availability
- Consider transmission needs to interconnect offshore wind locations based on the NREL offshore wind report
- Community engagement is needed early in the process to communicate additional transmission needs

### *Inertia Requirement*

- Despite the negligible cost difference<sup>23</sup> in resulting plans with and without the minimum inertia requirement modeled in RESOLVE, the Company will remove the minimum inertia requirement from the RESOLVE optimization as to not limit or bias resources that can be selected to fulfill various grid services.
- Inertia needs will be verified in the system security step of the process. This may increase the modeling iterations that are needed to ensure grid needs are adequately met.

---

<sup>23</sup> See July 14, 2021 STWG Meeting Presentation at pages 26-28, available at: [https://www.hawaiianelectric.com/documents/clean\\_energy\\_hawaii/integrated\\_grid\\_planning/igp\\_meetings/20210714\\_presentation\\_slides\\_igp.pdf](https://www.hawaiianelectric.com/documents/clean_energy_hawaii/integrated_grid_planning/igp_meetings/20210714_presentation_slides_igp.pdf)



---

## 2.4 STAKEHOLDER AREAS OF DISAGREEMENT

### *High EV Forecast*

Following the June 17, 2021 STWG meeting, Blue Planet provided two additional sources of information on June 29, 2021, to inform their suggested sensitivity representing a policy of 100% zero emissions vehicles by 2045 in the high customer technology adoption bookend. The first was the Transcending Oil Report prepared by the Rhodium Group in 2018.<sup>24</sup> The second was Blue Planet's self-developed estimate using the State Energy Office's Monthly Energy Trends data and a regression for the past 5 years on electric vehicle registrations. Saturation curves were developed using the data provided by the Transcending Oil Report and Blue Planet's estimate.

At a July 9, 2021 meeting with a smaller group of stakeholders, the Company commented that the data provided in the Transcending Oil Report provided a fuller set of assumptions to develop a forecast while Blue Planet's estimate could be further supplemented with data on scrappage rates or number of years that drivers retain their vehicles and the total vehicle count assumed to develop proper saturation curves. In reviewing the preliminary saturation curves, the Company noted that the Transcending Oil curve was a better candidate for the high bookend because it tracked above the base forecast. The Blue Planet curve overlapped with base forecast through the first 10 years and would not be as informative as a bookend and the Company inquired if curves could be provided for each island.

On July 27, 2021, the Company and Blue Planet met to further discuss Blue Planet's 100% ZEV forecast. Given the original forecast provided by Blue Planet was at the State-level, the Company requested if individual island saturation curves could be provided. On July 29, 2021, Blue Planet provided updated electric vehicle saturation forecasts for O'ahu, Maui, and Hawai'i Island. Blue Planet explained that data was not provided for Moloka'i and Lāna'i because the State Energy Office's Monthly Energy Trends data does not include registered electric vehicle counts for Moloka'i and Lāna'i. Data would also need to be provided for Moloka'i and Lāna'i to develop a high bookend for those islands. Because the additional data was received from Blue Planet late in the process, the Company was not able to both develop forecasts using the data and vet the resulting forecasts with the broader stakeholder groups. However, the Transcending Oil Report's saturation curve captures the feedback provided by Blue Planet within its bounds and was adopted for the high EV bookend.

---

<sup>24</sup> See Transcending Oil Report by Rhodium Group available at: [https://rhg.com/wp-content/uploads/2018/04/rhodium\\_transcendingoil\\_final\\_report\\_4-18-2018-final.pdf](https://rhg.com/wp-content/uploads/2018/04/rhodium_transcendingoil_final_report_4-18-2018-final.pdf)



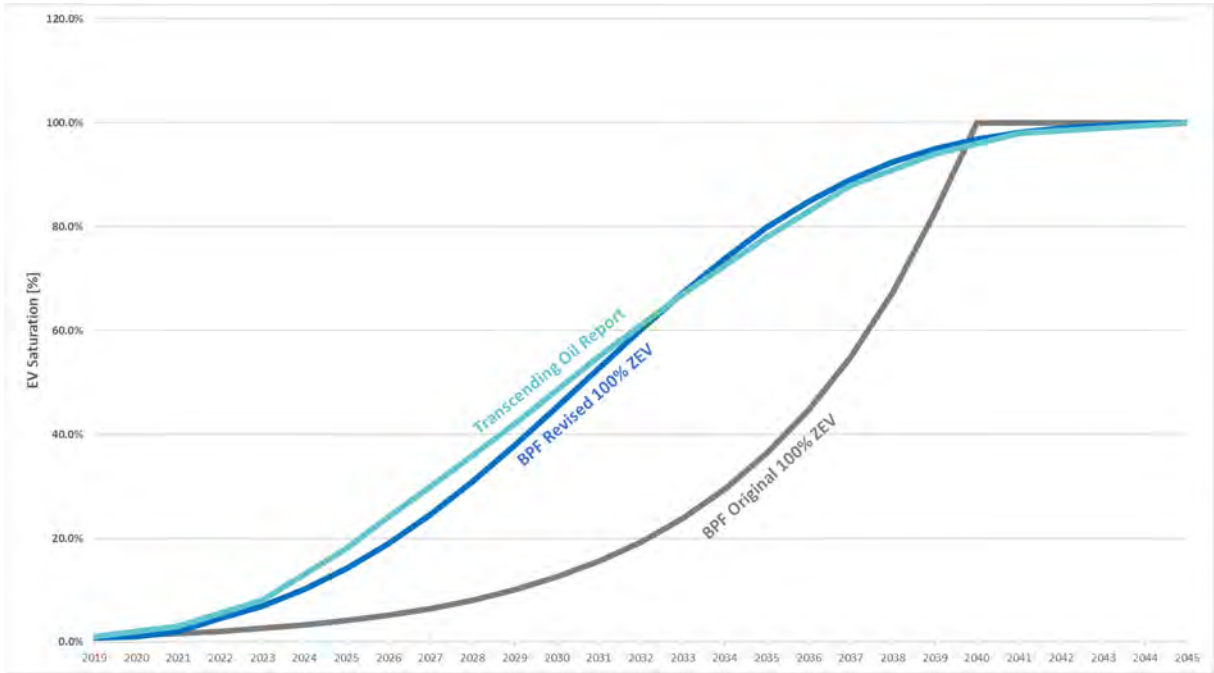

Figure 2-2: O'ahu High EV Bookend Sensitivity Comparison

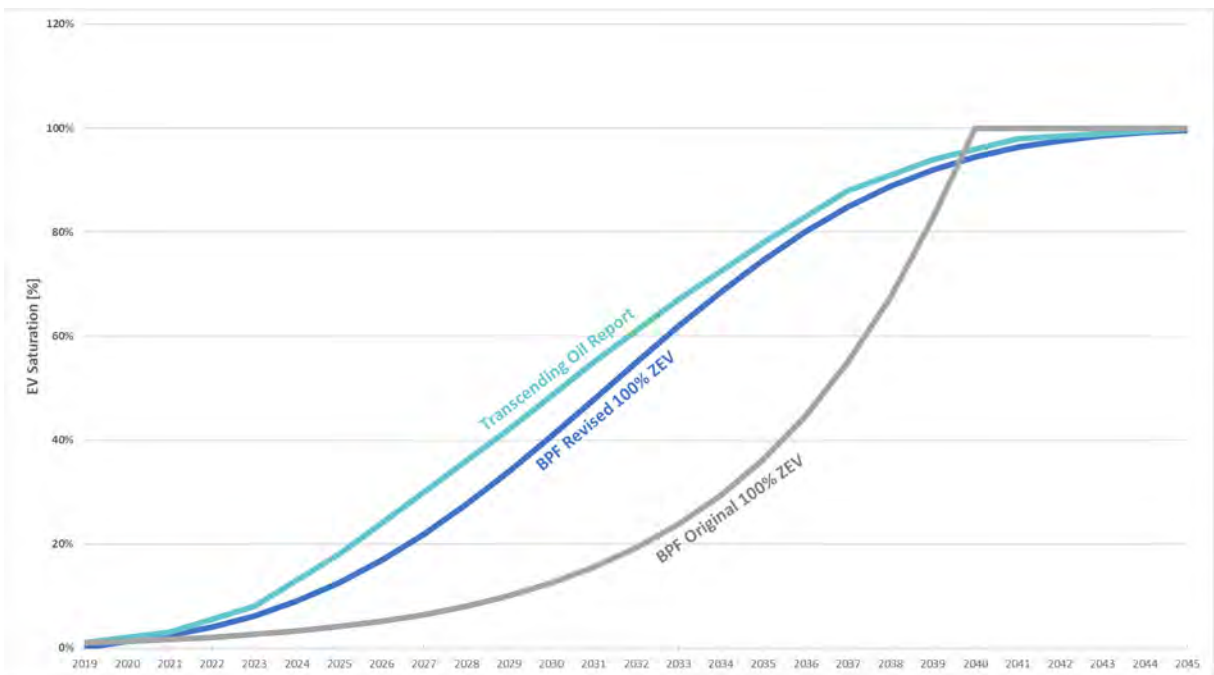

Figure 2-3: Maui High EV Bookend Sensitivity Comparison





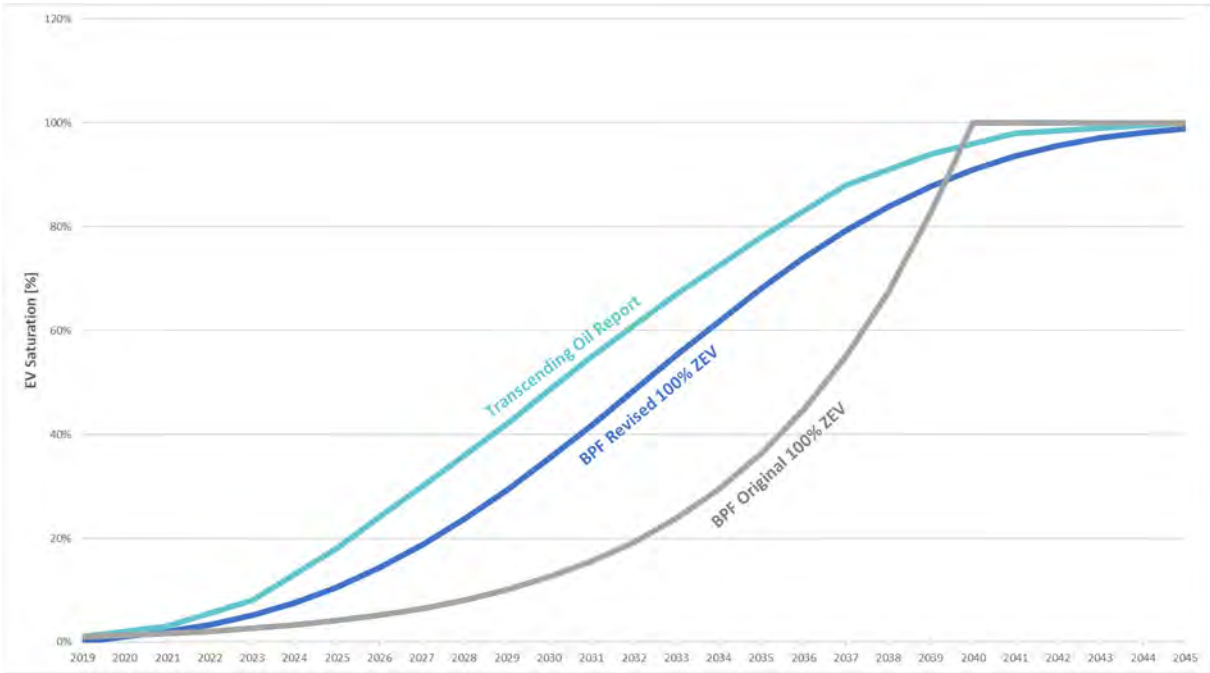

Figure 2-4: Hawai'i Island High EV Bookend Sensitivity Comparison

### *Grid-scale Solar and Wind Potential*

On the developable resource potential for onshore grid-scale PV and wind, the Company received stakeholder feedback that Federal contracting rules would require that the Department of Defense (“DoD”) seek the highest and best use for properties under their control, in addition to deciding whether that land would be made available for renewable energy development. Because of this circumstance, it would be difficult to make a blanket assumption that all DoD lands are available to develop. Further, stakeholders raised concerns on the ease of developing projects at slopes higher than 10% due to the additional work and cost involved. However, other stakeholders felt that higher slopes could be developed, up to 30%, with some additional cost adder. Because some projects have already been developed on steeper slopes, the Company is moving forward with excluding DoD lands but including slopes up to 30%. In addition to this base assumption, a Land Constrained scenario will be developed to test the possibility of future limited land availability for solar, wind, and biomass development and provide a meaningful bookend of analysis that incorporates stakeholder feedback to assume a lower amount of land is available for project development.

### *Fuel Forecasts*

On the fuel price forecasts, the Company views the high fuel price forecast using the EIA AEO high scenario as unrealistic because fundamentally, it assumes that high oil prices are sustained across the entire planning horizon. Historically, actual



Brent prices have breached the EIA high fuel price forecast at points in time but not in every year. The FGE fuel price forecast is a more accurate forecast of future fuel prices because it accounts for the tendency for the fuel prices to regress to the mean and for political drivers that can affect fuel prices.

The Company continued discussions with interested stakeholders on the concept of import/export parity and how it could affect the fuel price forecasts. Import parity is the price that a purchaser can expect to pay for an imported product (cost at market + freight + handling fees). Similarly, export parity is the price that a producer can expect to receive if its product were exported (cost at market – freight – handling fees). Import and export parity prices can be used to define a range of expected prices for a locally produced good. If there are multiple producers in the local market then the pricing is likely going to be closer to the export parity since neither producer will want to pay the cost of exporting their product. Similarly, if there is only one producer in the local market then the pricing is likely going to be closer to import parity since the purchaser wouldn't want to pay the cost of importing the product on their own.

As shown in Figure 2-5 below, in recent history, the estimated cost impacts if fuels were to be imported (higher dashed line) or exported (lower dashed line) represents the range of prices that constrain future fuel contract pricing. The higher dashed line represents the threshold price above which the Company is better off importing fuels instead of buying from Par (import parity) and the lower dashed line represents the threshold price below which Par is better off exporting their fuels instead of selling to the Company (export parity). The import / export adder varies due to the cost of freight and recent International Maritime Organization (“IMO”) regulations but generally is within the range of \$4 - \$6 per barrel. Par would want to sell to the Company at a cost based on the index plus an adder for freight and other considerations that remains just below the higher dashed line for import parity.

Under the latest amendment, the import cost could be as low as \$2 - \$3 per barrel if the Company were to decide to import. When there was more competition for the previous agreement, the pricing was as high as \$10 - \$12 per barrel below import parity. The Company was already paying close to import parity prior to 2015 and those data points are included in the regression that was performed to develop the fuel price forecasts.



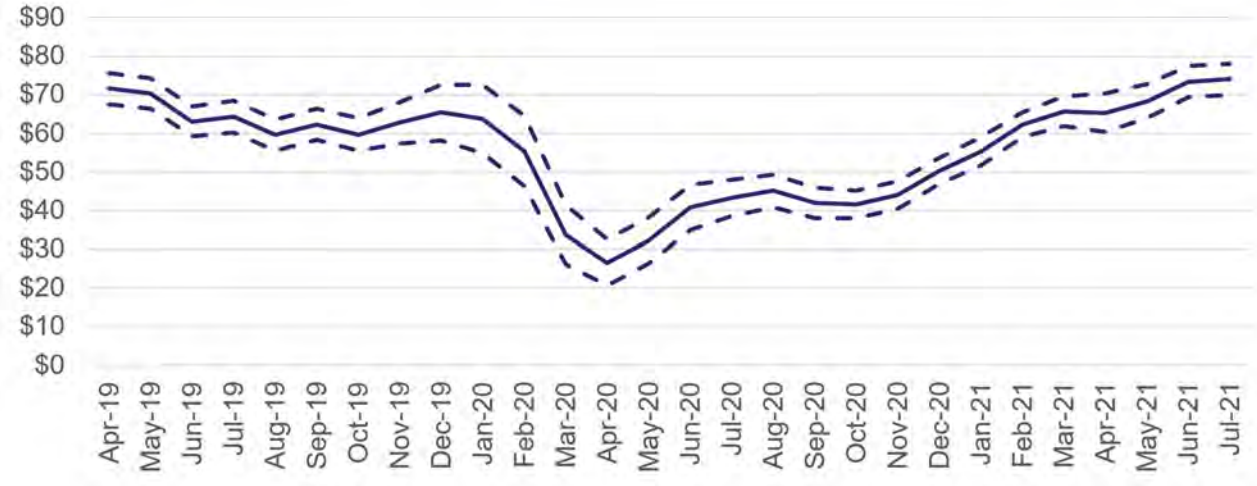

Figure 2-5: Fuel prices with estimated import / export adder

The historical purchase volume for LSFO is shown below in Figure 2-6. Prior to 2015, the Company was buying from both refineries, Chevron and Tesoro. After 2015, the Company was able to negotiate a lower cost contract because the two refineries had to compete for the Company’s demand for LSFO. However, now only one refinery remains. Refining margins decreased everywhere due to COVID-19 and are not expected to vary regionally between Hawaii and the mainland since fuel can be transported. However, the Par refinery on the west coast does have access to lower cost crude which may affect margins compared to other parts within its business.



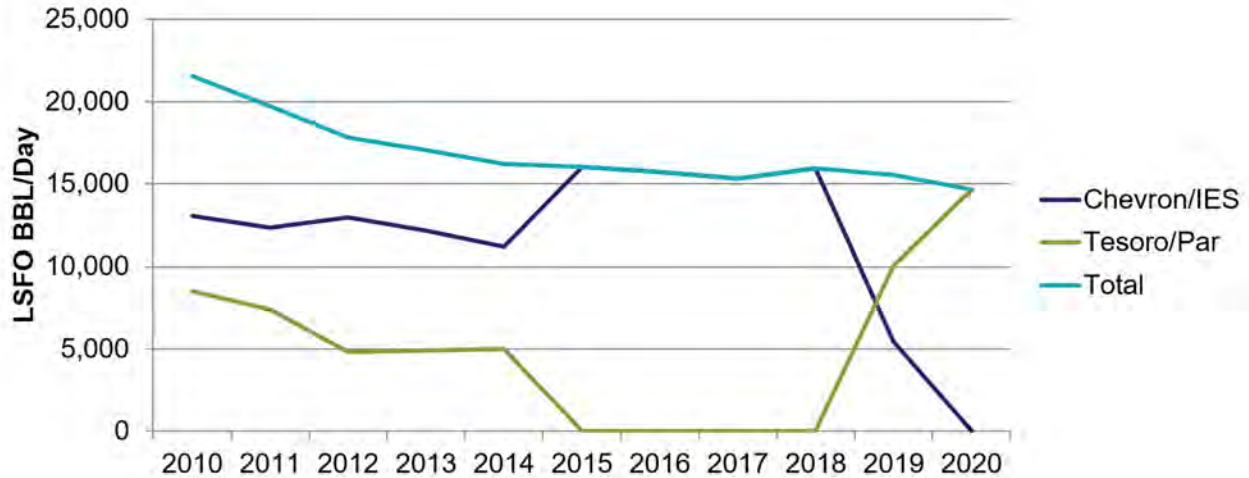

Figure 2-6: Historic LSFO Purchase Volume

In response to the Commission’s Review Point Guidance, and Ulupono’s position, the Company will adopt the EIA AEO reference, low and high forecasts. The intent is to examine worst case and best case scenarios and not weight resource plans that were developed using the EIA high and low fuel price forecasts because of concerns raised that the EIA high forecast is assumed to be a high fuel price that is sustained through the planning period and is much higher than historical actuals for Brent on the order of a 100% increase. With the large range between the EIA low and EIA high forecast, any scenario for a refinery shutdown and import option is covered by that spread.

## 2.5 PARKING LOT FOR ISSUES TO BE RESOLVED IN FUTURE PLANNING CYCLES

Through its latest round of stakeholder engagement, the Company established a parking lot list of items that were raised during stakeholder discussions that are worthy of consideration in future IGP cycles. The Company will continue to explore these areas with stakeholders; however, resolving these issues prior to starting the Grid Needs Assessment in this first IGP cycle, and therefore delaying the finalization of the inputs and assumptions does not outweigh its benefits. In some cases, the state of technology or modeling tools are areas that are still in development within the industry which also inhibits the ability to define modeling inputs to properly characterize the technology. It can be expected that more clarity in the future will allow for better incorporation into the IGP process. Additionally, data required to address some of parking lot items may not currently exist and require further evaluation on the viability and methodology of implementation in future IGP cycles. For example, the Company would need to better understand from stakeholders the intent, objective, and value of separating



DER Schedule-R forecast with the current limited data availability. Included below is a list of “parking lot” items thus far. The Company will continue to maintain this list as it progresses through the rest of the steps in the IGP process.

- Separating DER Schedule-R forecast into individual customer types:
  - Single Family Residences
  - Multi-Family Residences
  - Rentals
- Incorporating LoadSEER needs directly into RESOLVE
- Modeling EVs as a selectable resource in RESOLVE
- Defining the services EVs can provide.
- Modeling EV as a selectable resource and V2G
- Medium and heavy duty electric vehicle forecast



## 3 Overview of the RESOLVE and PLEXOS Models

Hawaiian Electric will use the RESOLVE model to produce a reference optimized resource plan that is then verified in PLEXOS through an hourly production simulation to capture total system costs as part of the Grid Needs Assessment.

---

### 3.1 RESOLVE CAPACITY EXPANSION MODEL

RESOLVE is a mixed-integer linear optimization model that is explicitly tailored to the study of electricity systems with high renewable and clean energy policy goals. The optimization performed in RESOLVE balances the fixed costs of new investments with variable costs of system operations, identifying a least-cost portfolio of resources to meet planning needs across a long-term horizon.

RESOLVE can solve for:

- Optimal investments in renewable resources, energy storage, thermal generating units as well as retention of existing thermal resources.

Subject to the following constraints:

- An annual renewable energy constraint that reflects the State of Hawai'i's Renewable Portfolio Standards policy;
- An Energy Reserve Margin constraint to maintain adequacy of supply for reliability;
- operational reserves for regulating reserve, and other flexibility services;
- Operational restrictions and performance characteristics for generators and resources;
- Hourly load requirements; and
- Constraints on the ability to develop specific new resources (timing and amount).

RESOLVE uses statistical sampling to downscale annual data to 30 representative days per year. These representative days are weighted based on historical data to capture operational costs under most conditions. In addition to the day sampling, resources with similar operating characteristics are aggregated to facilitate efficient solving for the optimized portfolio.

The day sampling algorithm is based on a mixed-integer linear program that allows selection of a sampled number of days using historical or synthetic timeseries data to find a subset of days that are representative of the long-run distributions for system load, wind, solar, and hydro conditions. The optimization



model minimizes the absolute error between the overall distribution of data and the sampled distribution for the selected days.

For example, a common implementation of the day sampling algorithm is to have 30 sampled days and select one representative day for summer peak, winter peak, and each month-weekday/weekend combination. This results in 26 represented day types that will be included in the final sample. Once the day sampling processing has selected an initial set of 26 day types, the overall sampling algorithm is rerun to find an additional 4 days to reduce the overall absolute error and calculate weights for each of the selected days.

Historical data to be used for sampling includes:

- Gross Load
- Aggregate Solar
- Aggregate Wind
- Net Load

The representative days developed for the RESOLVE modeling, including their day weights and distributions, are provided below. For each island, comparisons of the representative days to the historical distribution are provided for net load below. Consistent overlap of the net load duration curves and bins within the histograms indicate that the days selected for the RESOLVE modeling are representative of the expectations for the year.

*O’ahu*

Table 3.1: O’ahu Day Weights

Model Day	Weight	Historical Day
1	26.327	11/16/2016
2	20.132	8/8/2016
3	19.134	6/12/2016
4	18.757	5/30/2015
5	18.040	2/25/2016
6	17.242	3/4/2017
7	16.360	9/7/2015
8	16.312	1/31/2016
9	15.927	12/1/2016
10	15.806	4/27/2015
11	15.737	7/6/2017
12	15.243	7/31/2016
13	14.913	12/3/2018
14	14.668	1/26/2017



15	13.738	3/28/2016
16	13.407	10/11/2018
17	12.282	10/26/2018
18	12.222	5/9/2017
19	10.192	2/25/2018
20	9.801	6/8/2018
21	9.394	8/17/2017
22	8.126	4/6/2018
23	7.679	9/4/2016
24	6.049	4/26/2015
25	5.941	9/10/2018
26	5.291	10/21/2017
27	2.654	11/23/2018
28	1.453	8/11/2018
29	1.175	12/10/2017
30	1.000	11/13/2016

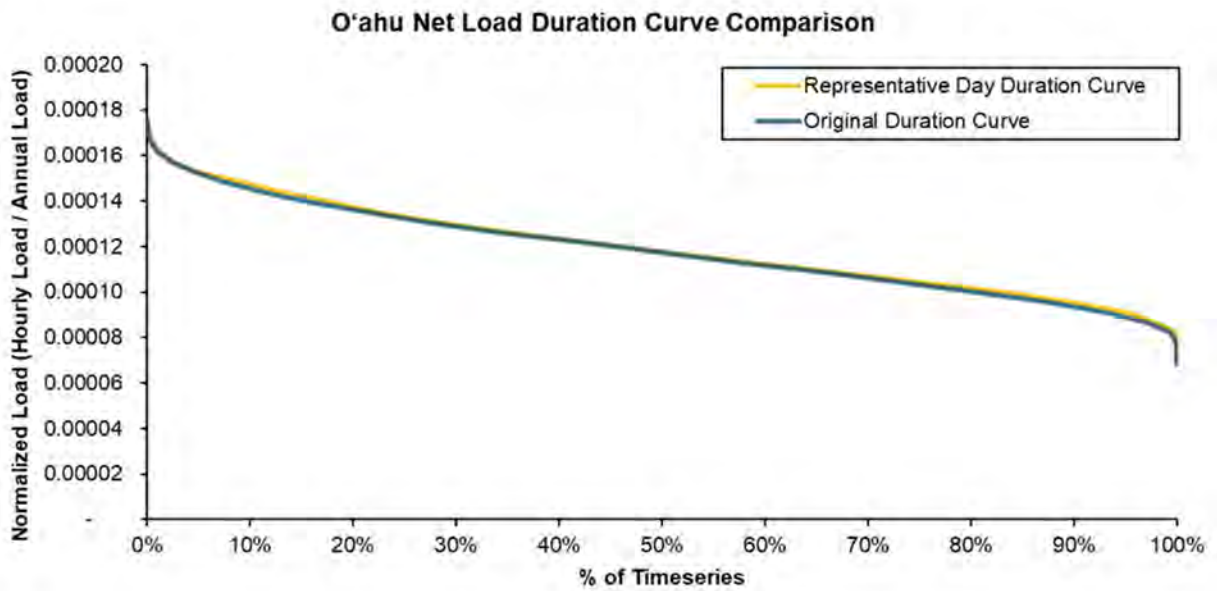

Figure 3-1: O'ahu Net Load Duration Curve Comparison





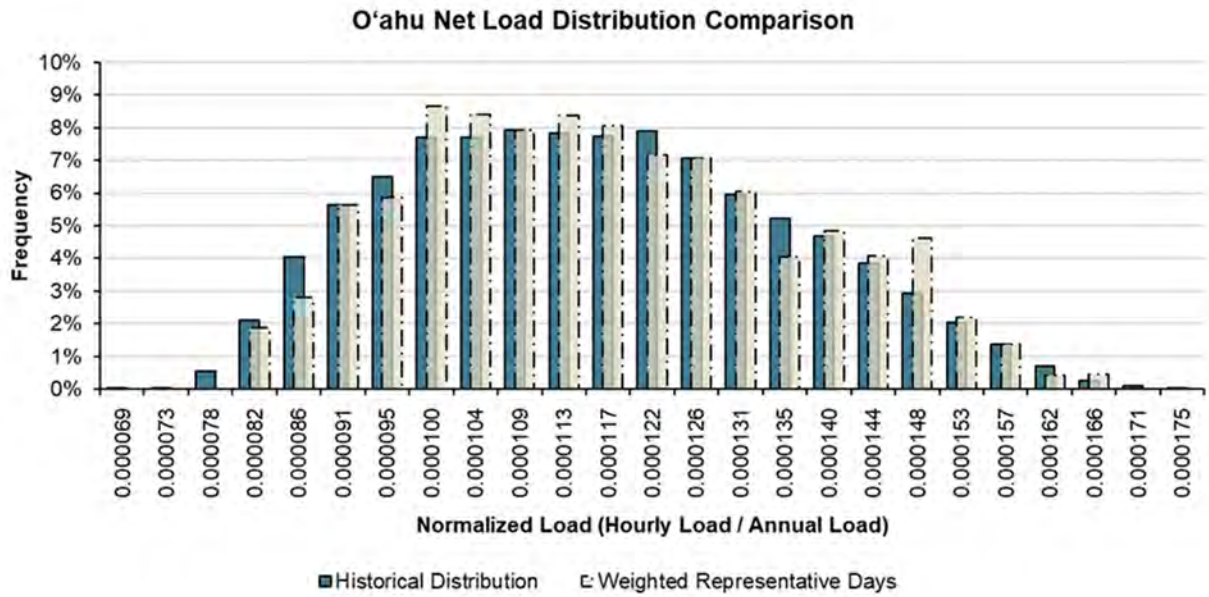

Figure 3-2: O'ahu Net Load Distribution Comparison

*Hawai'i Island*

Table 3.2: Hawai'i Island Day Weights

Model Day	Weight	Historical Day
1	29.984	8/3/2017
2	26.625	4/5/2016
3	26.040	2/3/2017
4	25.358	6/9/2016
5	21.690	1/24/2017
6	21.568	5/8/2015
7	19.093	10/10/2016
8	18.935	3/11/2015
9	16.383	11/26/2015
10	16.315	12/5/2017
11	15.444	7/8/2017
12	15.337	9/10/2017
13	14.647	9/3/2018
14	13.647	7/6/2017
15	11.958	12/17/2016
16	11.891	10/22/2017



17	11.049	3/3/2018
18	9.294	1/3/2016
19	8.416	5/7/2017
20	8.101	11/3/2016
21	5.500	11/11/2017
22	4.626	6/25/2017
23	3.359	4/21/2018
24	2.703	12/21/2018
25	1.893	7/20/2016
26	1.144	2/14/2016
27	1.001	2/16/2017
28	1.000	3/19/2015
29	1.000	8/20/2017
30	1.000	5/11/2018

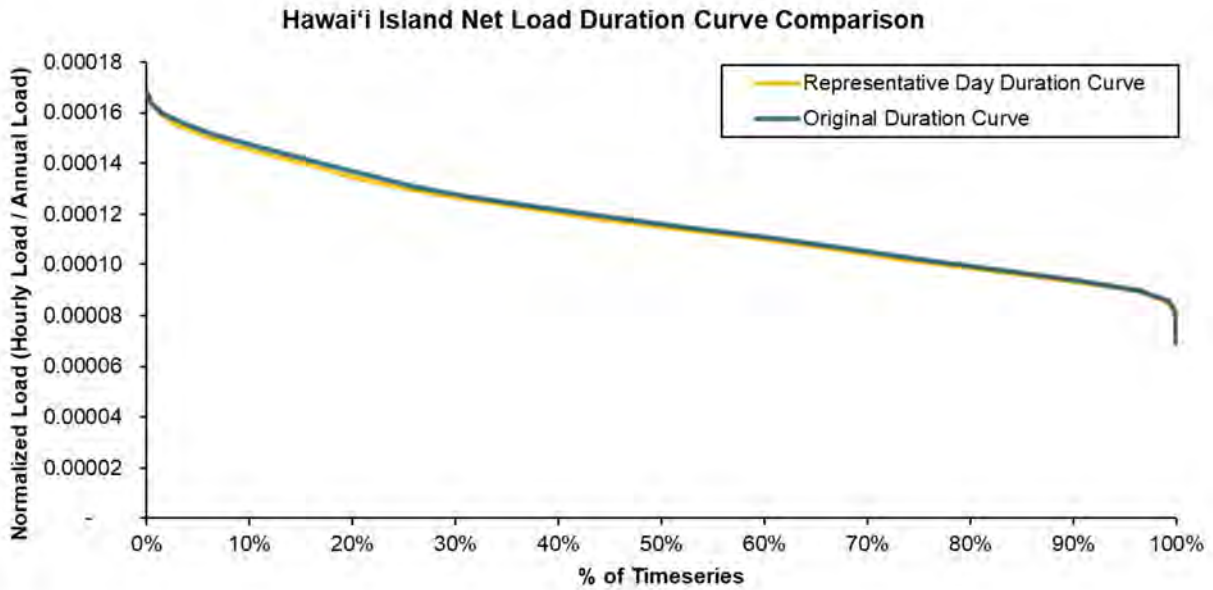

Figure 3-3: Hawai'i Island Net Load Duration Curve Comparison



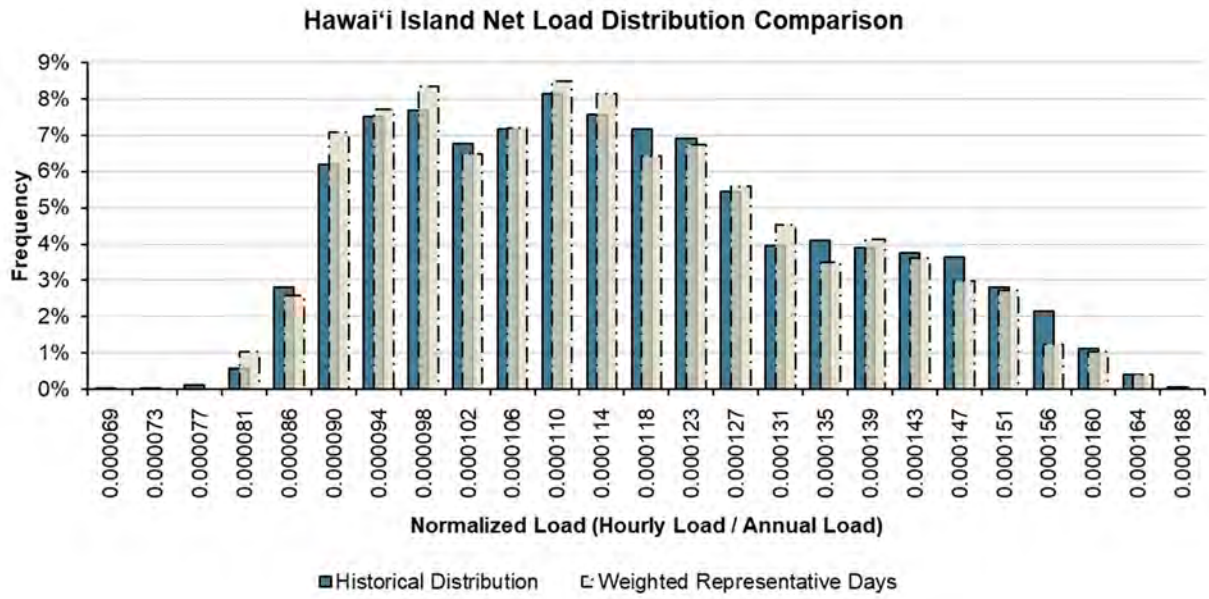

Figure 3-4: Hawai'i Island Net Load Distribution Comparison

*Maui*

Table 3.3: Maui Day Weights

Model Day	Weight	Historical Day
1	20.599	2/6/2018
2	20.506	5/16/2016
3	18.987	8/18/2018
4	18.818	4/18/2017
5	18.208	1/31/2016
6	18.081	6/15/2017
7	17.924	7/22/2016
8	17.295	9/11/2016
9	16.926	11/24/2017
10	16.855	3/25/2015
11	14.129	3/29/2015
12	14.038	10/20/2016
13	12.776	1/17/2017
14	12.689	9/28/2018
15	12.282	12/26/2016
16	12.214	12/22/2018



17	11.996	8/6/2015
18	11.903	6/12/2016
19	11.167	4/10/2016
20	11.166	10/17/2015
21	10.124	11/8/2016
22	8.674	7/26/2018
23	6.810	5/31/2015
24	6.586	2/14/2016
25	6.479	12/23/2015
26	5.780	10/3/2016
27	4.386	7/8/2017
28	3.667	5/4/2018
29	2.934	11/21/2015
30	1.000	2/19/2016

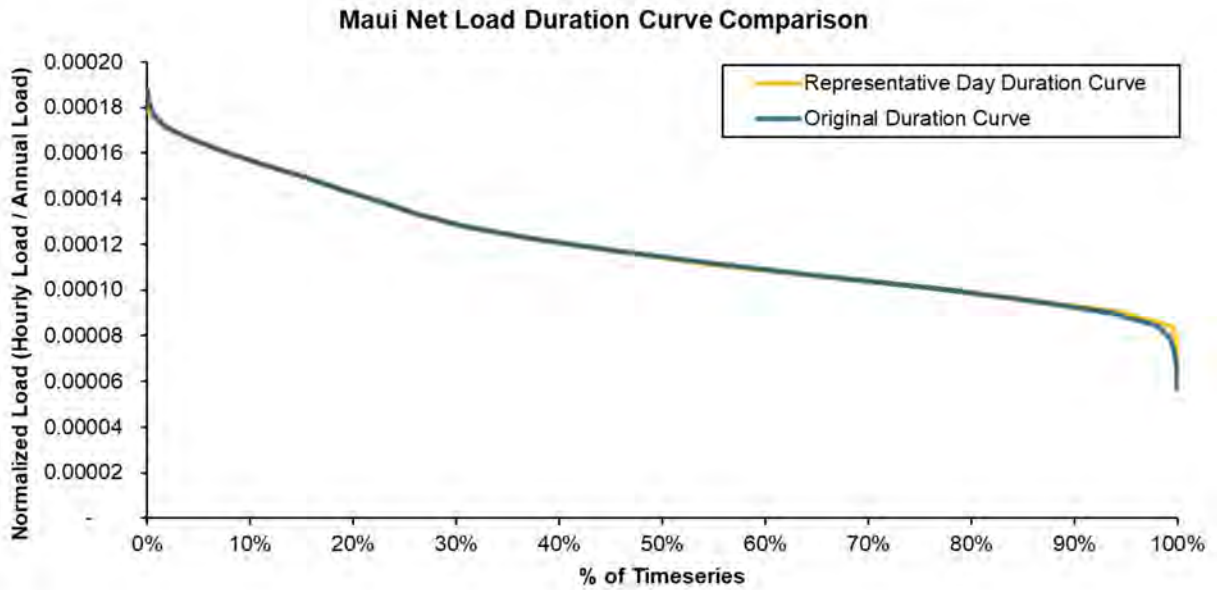

Figure 3-5: Maui Net Load Duration Curve Comparison



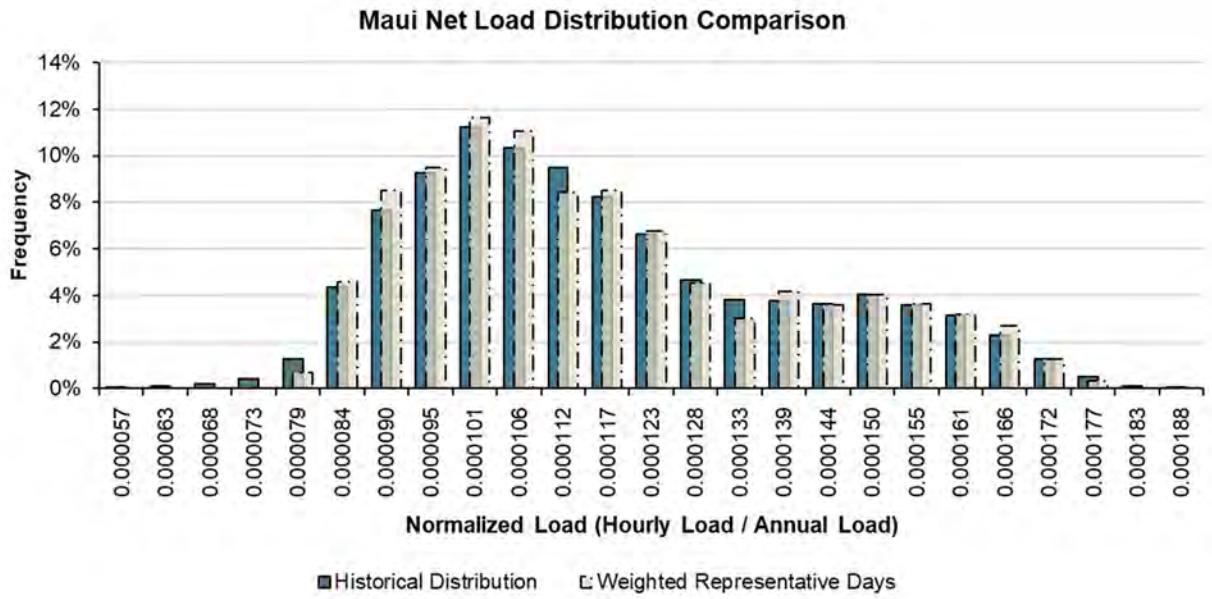

Figure 3-6: Maui Net Load Distribution Comparison

*Moloka'i*

Table 3.4: Moloka'i Day Weights

Model Day	Weight	Historical Day
1	26.64	7/23/2017
2	23.83	8/23/2017
3	21.21	9/1/2018
4	19.75	1/21/2017
5	16.96	3/22/2017
6	16.42	2/27/2017
7	15.78	11/2/2018
8	15.74	5/4/2018
9	15.63	6/9/2018
10	15.53	12/25/2017
11	15.45	12/22/2018
12	15.43	10/31/2018
13	15.24	5/20/2017
14	15.07	4/16/2018
15	14.03	3/25/2017
16	13.35	6/8/2018



17	13.20	11/22/2017
18	12.09	10/14/2018
19	11.80	4/7/2017
20	11.76	2/18/2018
21	11.23	1/17/2017
22	8.77	9/28/2018
23	6.16	8/18/2018
24	3.47	10/30/2018
25	3.35	7/14/2018
26	3.12	4/22/2017
27	1.00	6/15/2017
28	1.00	7/13/2017
29	1.00	8/2/2017
30	1.00	11/11/2017

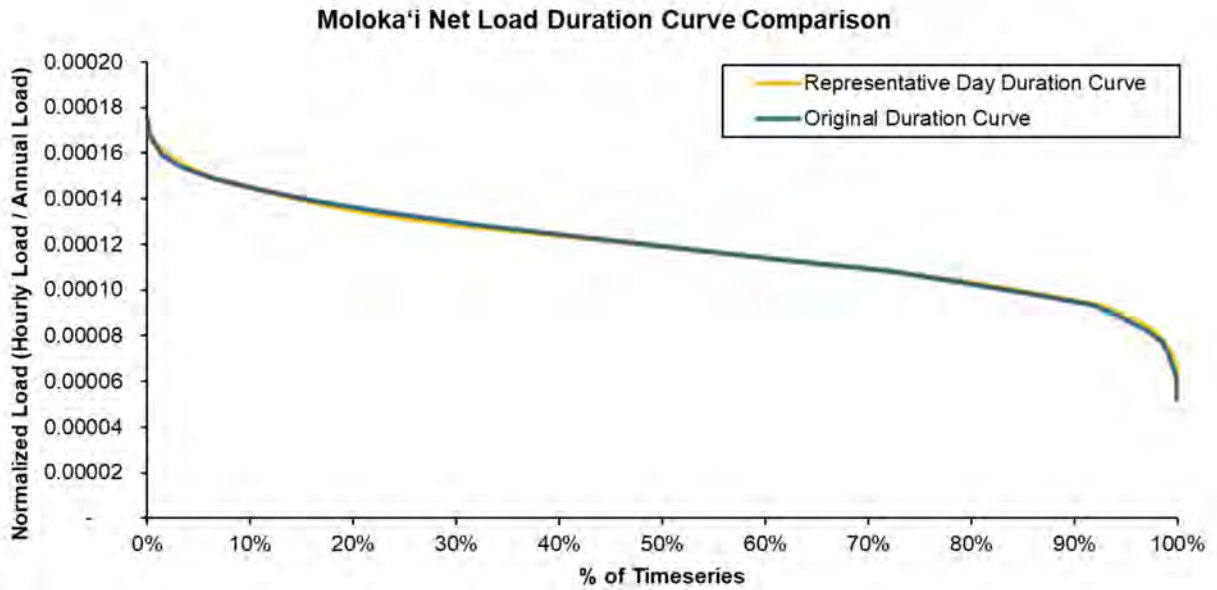

Figure 3-7: Moloka'i Net Load Duration Curve Comparison



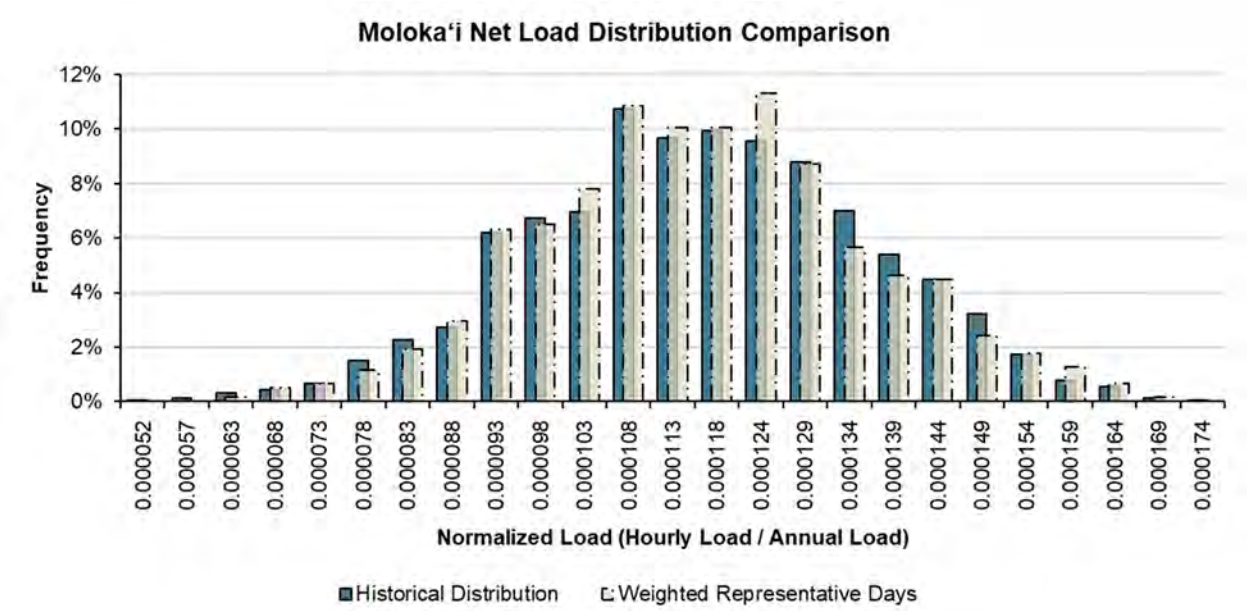

Figure 3-8: Moloka'i Net Load Distribution Comparison

*Lāna'i*

Table 3.5: Lāna'i Day Weights

Model Day	Weight	Historical Day
1	26.803	1/17/2017
2	26.214	7/18/2017
3	23.755	10/13/2017
4	19.847	8/11/2017
5	19.206	9/3/2018
6	18.965	6/15/2017
7	18.125	5/11/2017
8	17.128	2/18/2018
9	16.906	3/9/2018
10	16.280	12/22/2018
11	15.442	4/15/2018
12	14.708	12/6/2017
13	14.559	4/18/2018
14	14.104	11/12/2018
15	13.095	3/3/2018
16	11.876	5/10/2018





17	11.036	6/24/2017
18	10.873	2/14/2018
19	10.795	9/22/2018
20	10.155	8/30/2017
21	8.079	11/15/2018
22	7.818	11/11/2017
23	6.247	10/8/2018
24	4.198	1/20/2018
25	3.787	7/14/2018
26	1.000	5/6/2017
27	1.000	7/13/2017
28	1.000	3/21/2018
29	1.000	8/18/2018
30	1.000	10/6/2018

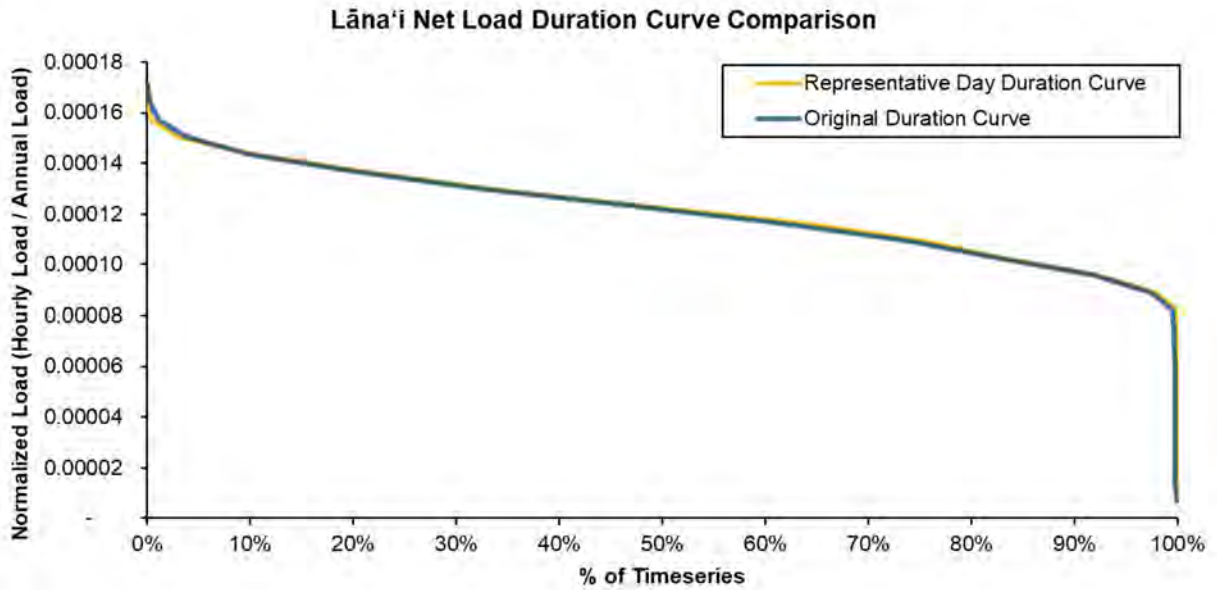

Figure 3-9: Lāna'i Net Load Duration Curve Comparison





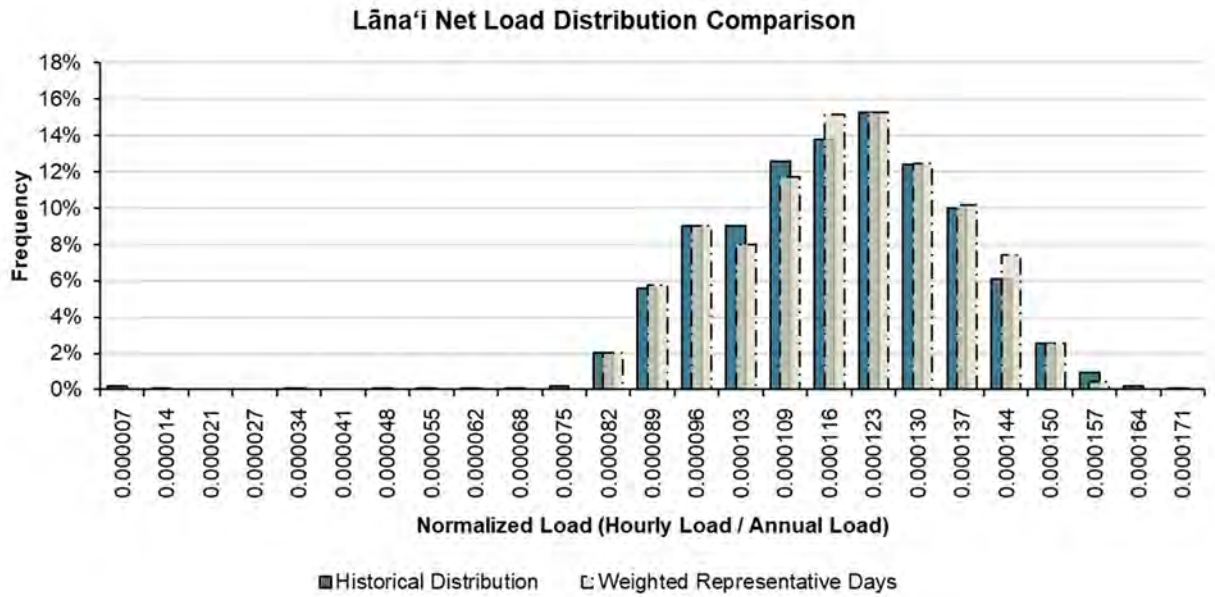

Figure 3-10: Lānaʻi Net Load Distribution Comparison

### 3.2 PLEXOS PRODUCTION SIMULATION MODEL

PLEXOS is a production simulation model that analyzes the chronological, hour-by-hour operation of a utility’s generation system. PLEXOS dispatches (mathematically allocates) the forecasted hourly net megawatt (MW) load among the dispatchable generating units in operation. Unit commitment (starting and stopping of units) and dispatch levels of generation are generally based on fuel cost and unit efficiency.

The net load – that is, the load remaining after partly being served by non-dispatchable energy – is allocated to the dispatchable resources such that overall fuel expense of the system is minimized (i.e., economically dispatched) within the constraints of the system. The model calculates the fuel consumed using the generating unit dispatch described above. The total fuel consumed is the summation of hourly fuel consumption from all the generating units.

The PLEXOS modeling software provides the flexibility to model a wide range of current and future technologies, such as energy storage, demand response, variable generation renewable resources, firm renewable resources and fast starting resources.

The key inputs to the PLEXOS production simulation model, as applied to the Hawaiian Electric system, are as follows:



- Hourly load to be served by all units (dispatchable and non-dispatchable);
- Operating characteristics of each Hawaiian Electric and IPP generating unit;
- Operating constraints such as system inertia, fast frequency response, and regulating reserve requirements;
- Contractual terms for IPP generating units;
- Planned maintenance schedules for the generating units;
- Estimated forced outage rates for Hawaiian Electric and thermal IPP generating units;
- Prices for fuels used by the dispatchable generating units; and
- Hourly MW profiles for non-dispatchable, variable renewable generation sources.

Inputs workbooks for O‘ahu, Hawai‘i Island, Maui, Moloka‘i, and Lāna‘i will be made available on the Company’s IGP website and provide additional information on the modeling inputs used by the RESOLVE and PLEXOS models.



## 4 Forecast Assumptions

The modeling process for the Grid Needs Assessment relies on a set of forecast assumptions to define what the future system could look like. Many of these assumptions have been developed by the Forecast Assumptions Working Group (FAWG), the Solution Evaluation & Optimization Working Group (SEOWG), and the STWG.

---

### 4.1 LOAD FORECAST

The load forecast is a key assumption for the planning models that provides the energy requirements and peak demands that must be served by Hawaiian Electric through the planning horizon. The forecasts will be used to start the planning process along with sensitivities discussed with the TAP, FAWG, SEOWG, and STWG. Because of the importance of the load forecast and peak demand in resource modeling, the TAP recommended the use of high and low bookends to test how the cost and portfolio of resources would change for a range of peak demand and load profiles. The load forecast is just one of the many assumptions that the resource planners use in their models to stress test the various plans under varying conditions. Scenario and sensitivities as described in Section 6 were developed to help address uncertainty in providing a range of forecasts to plan around given the uncertainties surrounding adoption of behind the meter technologies, which ultimately drive the load forecast and peak demand. Additional sensitivities may also be identified in the resource planning stage.

The forecasts were developed for each of the five islands and began with the development of the energy forecast (i.e., sales forecast) by rate class (residential, small, medium and large commercial and street lighting) and by layer (underlying load forecast and adjusting layers – energy efficiency, distributed energy resources, and electrification of transportation).

The underlying load forecast is driven primarily by the economy, weather, electricity price, and known adjustments to large customer loads and is informed by historical data, structural changes<sup>25</sup>, and historical and future disruptions. The impacts of energy efficiency (EE), distributed energy resources (DER), primarily photovoltaic systems with and without storage (i.e., batteries), and electrification of transportation (light duty electric vehicles (EV) and electric buses (eBus), collectively “EoT”) were layered onto the underlying sales outlook to develop the sales forecast at the customer level.

---

<sup>25</sup> Structural changes include the addition of new resort loads or new air conditioning loads that have a persistent impact on the forecast.



Multiple methods and models were analyzed to develop the underlying forecast as presented in the July 17, 2019 FAWG meeting.<sup>26</sup> The forecasts and assumptions presented in the FAWG meetings held from March 2019 through March 2020 and described in the response to PUC-HECO-IR-1<sup>27</sup> were developed prior to the unprecedented global and local events of the COVID-19 pandemic and therefore do not include impacts of the virus on the forecasts. The Company updated its forecasts to account for the impacts of COVID-19 as presented in the August 31, 2020 FAWG meeting and described further in Appendix C: Forecast Methodologies.<sup>28</sup> Feedback from stakeholders on the assumptions used to develop the forecasts and the resulting forecast were an important part of the process and are summarized in [IGP Stakeholder Feedback Summary, March 2021](#). Additional updates made based on recent stakeholder engagement in response to the Review Point Guidance are described throughout this document.

The residential and commercial sectors are forecasted separately as each sector’s electricity usage has been found to be related to a different set of drivers as described in Appendix C: Forecast Methodologies. Historical recorded sales used in econometric models are adjusted to remove sales impact of DER, EE and EoT, which are treated as separate layers. Input data sources for developing the underlying sales forecast include economic drivers, weather variables, electricity price and historical data from the Company’s own assumptions, as shown in the table below.

Table 4.1: Input Data Sources for Underlying Forecast

University of Hawaii Economic Research Organization	Real personal income Resident population Non-farm jobs Visitor arrivals
NOAA – Honolulu, Kahului, Hilo and Kona Airports	Cooling degree days Dewpoint Temperature Rainfall
Itron, Inc.	Commercial energy intensity trend for Pacific Region for non-heating/cooling end uses.
Hawaiian Electric	Recorded kWh sales Recorded customer counts Large load adjustments Real electricity price

<sup>26</sup> See [https://www.hawaiianelectric.com/documents/clean\\_energy\\_hawaii/integrated\\_grid\\_planning/stakeholder\\_engagement/working\\_groups/forecast\\_assumptions/20190717\\_wg\\_fa\\_meeting\\_presentation\\_materials.pdf](https://www.hawaiianelectric.com/documents/clean_energy_hawaii/integrated_grid_planning/stakeholder_engagement/working_groups/forecast_assumptions/20190717_wg_fa_meeting_presentation_materials.pdf), slides 10-12.

<sup>27</sup> See [https://www.hawaiianelectric.com/documents/clean\\_energy\\_hawaii/integrated\\_grid\\_planning/stakeholder\\_engagement/working\\_groups/forecast\\_assumptions/dkt\\_20180165\\_20200702\\_HECO\\_response\\_to\\_PUC\\_IRs\\_1-2.pdf](https://www.hawaiianelectric.com/documents/clean_energy_hawaii/integrated_grid_planning/stakeholder_engagement/working_groups/forecast_assumptions/dkt_20180165_20200702_HECO_response_to_PUC_IRs_1-2.pdf)

<sup>28</sup> See [https://www.hawaiianelectric.com/documents/clean\\_energy\\_hawaii/integrated\\_grid\\_planning/stakeholder\\_engagement/working\\_groups/forecast\\_assumptions/20200831\\_wg\\_fa\\_meeting\\_presentation\\_materials\\_HECO.pdf](https://www.hawaiianelectric.com/documents/clean_energy_hawaii/integrated_grid_planning/stakeholder_engagement/working_groups/forecast_assumptions/20200831_wg_fa_meeting_presentation_materials_HECO.pdf), slides 6, 9, 11, 13 and 16 for O’ahu, Maui, Moloka’i, Lāna’i and Hawai’i islands respectively.



### 4.1.1 Distributed Energy Resource Forecasts

Through the STWG, the DER Docket proceeding, and other meetings, the DER forecasts have been updated, including the development of a high and low forecast for the bookend sensitivities. Several stakeholder suggestions were made at the June 17, 2021 STWG meeting<sup>29</sup> to develop bookend DER forecasts and revisions to the base scenario. Stakeholder comments included:

- There are pockets of schedule-R (multi-family residences) that are not currently reachable in the DER market, and this has more to do with a lack of available programs for these customers. It’s more of a policy issue than a DER supply issue. Specifically, there are AOAOs that are not currently reachable.
- For the bookend, one way is to remove the addressable market constraints.
- Are we looking at bookends from the perspective of capturing untouched markets, such as rental properties? How much DER should be included in load versus how much is export?
- It seems to make sense as a realistic possibility [to extend tax credits].
- In the longer term, it is reasonable to consider an export program extension in the base case as well as in the high bookend scenario.

As a direct result of this feedback, Table 4.2, below summarizes the changes and assumptions the Company made in the development of the updated DER forecasts.

Table 4.2. Summary of assumptions used to develop DER forecast sensitivities

Input	No State ITC	Low	Base	High
Synopsis	Revised lower DER uptake below market forecast	Market Forecast based on self-consumption	Revised uptake based on DER docket proposals (The Company), include EDRP (Oahu, Maui), expanded addressable market	Revised uptake based on DER docket proposals (DER Parties), include EDRP, updated resource costs, expanded addressable market
Cost Projections	NREL ATB - Moderate	NREL ATB - Moderate	NREL ATB - Moderate	NREL ATB Advanced
Federal Tax Credits	Dec 2020 COVID-19 Relief	Dec 2020 COVID-19 Relief	Dec 2020 COVID-19 Relief	10-year extension
State Tax Credits	0%	Increased 2021 to 35%	Increased 2021 to 35%	Increased 2021 to 35%
Includes EDR Program	No	No	Yes (Oahu, Maui)	Yes
Long Term Upfront Incentives	None	None	\$250/kW (Oahu, Maui)	\$500/kW

<sup>29</sup> Available at, [https://www.hawaiianelectric.com/documents/clean\\_energy\\_hawaii/integrated\\_grid\\_planning/igp\\_meetings/20210617\\_stwg\\_meeting\\_notes.pdf](https://www.hawaiianelectric.com/documents/clean_energy_hawaii/integrated_grid_planning/igp_meetings/20210617_stwg_meeting_notes.pdf)



Long Term Export Program	NA	NA	Standard DER Tariff (All Islands) with Scheduled Dispatch (Oahu, Maui)	Smart Export+ with Scheduled Dispatch
Addressable Residential Market	Single Family/2-4 Unit Multi-Family/Owner Occupied/Consumption Threshold	Single Family/2-4 Unit Multi-Family/Owner Occupied/Consumption Threshold	Single Family/2-4 Unit Multi-Family/Owner Occupied/Consumption Threshold	Single Family/2-49 Unit Multi-Family/Consumption Threshold
Addressable Commercial Market	Public or Private Owned/<6 stories/Consumption Thresholds	Public or Private Owned/<6 stories/Consumption Thresholds	Public or Private Owned/<6 stories/Consumption Thresholds	Public or Private Owned/<6 stories/Consumption Thresholds/Expand Sch-P Customer Pool to 100%
Add-Ons	NEM+	NEM+	Sch-R NEM above minimum bill customers from 2021-2023 (Oahu, Maui), NEM+ <sup>30</sup>	Sch-R NEM customers from 2021-forward

The DER layer includes impacts of behind the meter PV and battery energy storage systems as well as known projects for other technologies (e.g., wind). This forecast adjustment estimated new additions of DER capacity in each month by island, rate class and program, and projected the resulting monthly sales impact from these additions. Future DER capacity modeling considered two-time horizons:

- Near term (next one to three years) reflects the current pace of incoming applications and executed agreements, existing program (NEM, NEM+, SIA, CGS, GSP, CSS and ISE)<sup>31</sup> subscription level and caps, feedback from the Companies' program administrators and installers, customer input and any studies or upgrades being done to address short-term hurdles (e.g. circuit study, equipment upgrades) that affect the installation pace; and
- Longer term forecast is model-based as the detailed application information is not available.

To extend the DER forecast from the short-term through the full planning period an economic choice model using simple payback considers a set of assumptions such as the installed cost of PV and battery, installation incentives, electricity price, program structure that affect the economic benefit to the customer which is the primary driver of their decision to adopt the system. The addressable market, or

<sup>30</sup> Customers participating in NEM+ is included in the Base case scenario for all islands, but only from 2024-forward for Oahu and Maui because Schedule-R NEM customers were re-introduced in the customer pool for 2021-2023.

<sup>31</sup> Existing programs include Net Energy Metering, Net Energy Metering Plus, Standard Interconnection Agreement, Customer Grid Supply, Customer Grid Supply Plus, Customer Self Supply, and Interim Smart Export.



the number of utility customers that have the potential to install a DER behind the meter is also considered.

Another important assumption to consider was the structure of programs. There is an array of program choices today, some of which are subject to capacity caps. Assumptions were made as to the structure of future programs for the long term after obtaining input and perspectives from program administrators/designers, industry, and policy/consultancies. The future new tariff is assumed to have compensation for export<sup>32</sup> that is aligned with system needs and allows for controllability during system emergencies. The export compensation and tariff structure was based on the Standard DER Tariff for all islands proposed by the Company in the DER docket<sup>33</sup>. Insight from the DER panel members on the Panel of Experts meeting held on March 22, 2019 as well as already interconnected systems, applications and permit data show that customers are choosing to use battery storage to shift their generation to offset their own load rather than exporting to the grid during the daytime. In addition, for O‘ahu and Maui, the DER forecast also incorporated the Emergency Demand Response Program (EDRP), Scheduled Dispatch program<sup>34</sup>, and assumed that an upfront incentive of \$250/kW would continue to be available beyond EDRP for new DER customers in exchange for provision of grid services (i.e., bring your own device programs) as part of a long-term DER program. Consistent with the EDRP, incentives would be paid based on performance and commitment of the customer resource.

Under the EDRP assumption, DER customers are modeled to export at the battery system’s rated capacity [kW] (if energy is available) for a two-hour duration during the evening peak window, 5 PM to 9 PM, each day.

NREL 2021 Annual Technology Baseline (ATB) forecasts storage continues to decline in cost and it seems likely that compensation for daytime export will continue to be relatively low compared to retail rates, therefore the assumption was made that most future systems under the future tariff will be paired with storage. Furthermore, the rollout of a broad opt-out time-of-use (TOU) rate would increase the incentive to pair future systems with storage, adding additional credence to this assumption. Hawaiian Electric is including high and low scenarios, to test different rates of technology adoption by customers. Since advanced rate designs and long-term distributed energy resource programs are in the process of being finalized and implemented, the Companies will take a “best guess” approach to assume high and low levels of TOU adoption within the high and low scenarios.

---

<sup>32</sup> See Order No. 37066 issued on April 9, 2020 in Docket No. 2019-0323, Instituting a Proceeding to Investigate Distributed Energy Resource Policies pertaining to the Hawaiian Electric Companies.

<sup>33</sup> See Hawaiian Electric’s DER Program Track Final Proposal filed on May 3, 2021 in Docket No. 2019-0323, Instituting a Proceeding to Investigate Distributed Energy Resource Policies pertaining to the Hawaiian Electric Companies.

<sup>34</sup> See Order No. 37816 issued on June 8, 2020 in Docket No. 2019-0323, Instituting a Proceeding to Investigate Distributed Energy Resource Policies pertaining to the Hawaiian Electric Companies.



These assumptions based on stakeholder feedback and information from the DER Docket proceeding, represent the collective best guess from all stakeholders. Though, potential impacts from adjustments made to these assumptions may not necessarily require restating the forecast since the “spread” between the low, base, and high forecast should sufficiently capture any impacts within the bounds of the forecasted sensitivities.

The current rate of DER applications and remaining capacities to reach set caps of interim programs, coupled with recent system configuration trends in DER applications were used to set the pace, capacities and amount of PV systems paired storage in the near term. The increasing trends in PV systems paired with batteries was observed among recent DER applications. The forecasted ramping up of paired storage systems was also supported from feedback received during the Panel of Experts meeting held on March 22, 2019 from industry leaders.<sup>35</sup> For residential systems in the near-term, the number of systems paired with storage increased from roughly 60% to as high as 95% for some islands in 2022. Similarly, the small and medium commercial classes had a ramping up of paired storage systems through the course of the near term to meet with the assumptions of the model that picks up after the near-term.

The model assumptions were that all small and medium commercial and all residential systems will be paired with storage after the near-term forecast. Storage size assumptions for each island and rate class were optimized based on return on investment for an average customer. By modeling average customer’s optimal pairing size, the amount of forecasted storage was appropriately captured for the overall rate class as customers with larger storage requirements offset those with smaller or no storage requirements. PV installs for large commercial customers were modeled without battery storage.

Monthly DER capacity factors for each island were used to convert installed capacity to customer energy reductions. The monthly capacity factors recognize the variations in solar irradiance throughout the year rather than using a single average annual capacity factor to more accurately reflect monthly variations in the energy production of DER systems. A degradation factor of 0.5% a year<sup>36</sup> was applied to the sales impacts to recognize that the DER system’s performance degrades over time.

For incentives, the following was assumed for Federal and State investment tax credits.

- Cap on residential PV-only systems: \$5,000 in all years

---

<sup>35</sup> See

[https://www.hawaiianelectric.com/documents/clean\\_energy\\_hawaii/integrated\\_grid\\_planning/stakeholder\\_engagement/working\\_groups/forecast\\_assumptions/20190522\\_wg\\_fa\\_meeting\\_presentation\\_materials.pdf](https://www.hawaiianelectric.com/documents/clean_energy_hawaii/integrated_grid_planning/stakeholder_engagement/working_groups/forecast_assumptions/20190522_wg_fa_meeting_presentation_materials.pdf)

<sup>36</sup> Median degradation rate from NREL “Photovoltaic Degradation Rates – An Analytical Review”, D.C. Jordan and S.R. Kurz, 2012, <http://www.nrel.gov/docs/fy12osti/51664.pdf>





- Cap on residential PV+storage systems: \$5,000 in 2019-2021, \$10,000 in 2022-forward

Table 4.3: Federal Tax Incentive Rate Schedule

Class	2019	2020	2021	2022	2023	2024+
Residential	30%	26%	26%	26%	22%	0%
Commercial	30%	26%	26%	26%	22%	10%

Table 4.4: State Tax Incentive Rate Schedule

2019	2020	2021	2022	2023	2024	2025	2026	2027+
35%	35%	35%	25%	25%	20%	20%	20%	15%

One of the key drivers in the long-term DER forecast is the addressable market, including customers that can add-on to existing systems. Expanding the addressable market compared to the original IGP market forecast assumption was a common theme from stakeholders. The addressable market for residential customers included single family and multi-family homes with a maximum of four units that were owner occupied and with a high enough energy consumption to utilize at least a 3 kW PV system. Historically, only 15-20% of residential PV installations have been below 3 kW. From a practical perspective, customers with low consumption are less likely to make an investment in rooftop PV. Smaller systems are also less cost-effective due to fixed portions of the installation and material costs being spread out over smaller total capacity and savings potential.

Stakeholders commented on the addressable market for DER customers at the June 17<sup>th</sup>, 2021 Stakeholder Technical Working Group meeting and June 28<sup>th</sup>, 2021 DER Docket Status Conference. For example, at the DER Docket Status Conference, stakeholders commented retrofitting existing DER customers with added PV capacity and battery systems would likely be the most attractive option to meet the EDRP’s 50 MW target. On June 8<sup>th</sup>, 2020, the Commission issued Order No. 37816 in Docket No. 2019-0323 approving the EDR Program and Scheduled Dispatch rider for new and existing DER customers<sup>37</sup>. Considering the comments and feedback provided by stakeholders and Order No. 37816, existing NEM customers who were not reaching a minimum bill were added to the addressable market from 2021 through 2023 for O’ahu and Maui. In addition, comments from stakeholders indicated that there might be DER customers who only install on a battery. However, others may increase their PV capacity to capture the total value of tax credits. Considering these comments, future retrofits for NEM

<sup>37</sup> See Order No. 37816 issued on June 8, 2020 in Docket No. 2019-0323, Instituting a Proceeding to Investigate Distributed Energy Resource Policies pertaining to the Hawaiian Electric Companies.



customers assumed both an addition of a battery system, 5 kW/13.5 kWh, and an increase in PV capacity, 5kW<sup>38</sup>.

Table 4.5: Addressable Market for Residential Customers

Island	Percent of Schedule R Customers	Average PV System Size (KW)	Average Storage Size (KWH)
O'ahu	37%	7.0	15.5
Hawai'i Island	41%	6.0	11.0
Maui	43%	7.0	15.0
Lāna'i	24%	4.0	9.0
Moloka'i	30%	4.0	12.0

Island	Percent of Schedule-R NEM Customers	Average PV System Size (KW)	Average Storage Size (KWH)
O'ahu	85%	5	13.5
Maui	71%	5	13.5

For commercial customers, public and private building ownership was considered. Structures greater than six stories were excluded. Similar to residential customers, small and medium commercial consumption needed to be above a set threshold. Commercial thresholds were established using rate class customers' previous 12-months usage, historical PV installation data, and business types. PV and non-PV customers were segmented by business type and distributions for total usage<sup>39</sup> were created for PV customers. Usage at the lower 1/8th quantile was used as the threshold for business types that had five or more customers who already installed PV. The default thresholds of 500kWh for Schedule G and 5,000 kWh for Schedule J are used for business types with less than five existing customers with PV already installed.

Table 4.6: Addressable Market for Commercial Customers

Island	Percent of Schedule G Customers	Percent of Schedule J Customers	Percent of Schedule P Customers
O'ahu	37%	53%	78%
Hawai'i	35%	68%	44%
Maui	41%	63%	68%

<sup>38</sup> Order No. 37816 permits existing PV customers to add up to 5 kW of additional PV generation capacity.

<sup>39</sup> Total usage is the sum of the previous 12-months sales plus the sum of the previous 12-months estimated PV generation.



Island	Percent of Schedule G Customers	Average PV System Size (KW)	Average Storage Size (KWH)
O'ahu	37%	7.0	12.5
Hawai'i	35%	5.5	9.5
Maui	41%	7.0	14.5

Island	Percent of Schedule J Customers	Average PV System Size (KW)	Average Storage Size (KWH)
O'ahu	53%	76.0	40.0
Hawai'i	68%	64.0	15.0
Maui	63%	59.0	45.0

Island	Percent of Schedule P Customers	Average PV System Size (KW)	Average Storage Size (KWH)
O'ahu	78%	330.0	0.0
Hawai'i	44%	64.0	0.0
Maui	68%	330.0	0.0

Table 4.10: Cumulative Distributed PV Capacity (kW)

Year	O'ahu	Hawai'i Island	Maui	Moloka'i	Lāna'i	Consolidated
kW	A	B	C	D	E	F = A + B + C + D + E
2025	723,234	138,801	158,260	3,200	1,050	1,024,545
2030	830,974	164,392	185,501	3,696	1,356	1,185,919
2040	993,411	209,179	227,968	4,476	1,888	1,436,922
2045	1,053,934	227,449	242,917	4,768	2,085	1,531,153
2050	1,104,843	243,258	255,327	4,952	2,226	1,610,606



Table 4.11: Cumulative Distributed BESS Capacity (kWh)

Year	O'ahu	Hawai'i Island	Maui	Moloka'i	Lāna'i	Consolidated
kWh	A	B	C	D	E	F = A + B + C + D + E
2025	317,754	84,230	128,263	1,348	515	532,110
2030	493,412	126,316	179,030	2,308	875	801,941
2040	756,521	196,611	254,943	3,976	1,550	1,213,601
2045	848,456	224,301	282,258	4,588	1,829	1,361,432
2050	923,096	247,272	303,603	5,068	2,072	1,481,111

*Advanced Rate Design Impacts*

One of the key components of the Advanced Rate Design (“ARD”) discussed in the DER docket includes the implementation of TOU rates, including mandatory TOU for DER customers. Consistent with ARD discussions, each customer that adopts DER (solar paired with storage) and/or electric vehicles under managed charging scenarios is effectively shaping their consumption to operate consistent with a TOU rate. For example, DER customers would charge their energy storage system with rooftop solar during the day and discharging the system in the evening, and in managed charging cases, customers charging electric vehicles during the day.

At the June 17, 2021 STWG, stakeholders asserted that the additional demand charge under the Company’s ARD proposal would affect the forecasted DER uptake. Under the current ARD proposal, new DER customers would be defaulted into a Three-Part TOU rate that includes a \$3/kW monthly demand charge. Referencing the Company’s Bill Comparison of 2017 TY and Proposed Three-Part TOU Rates under the ARD Track Initial Proposal<sup>40</sup>, a 300 kWh monthly usage and 3.336 kW peak residential customer’s monthly bill, including the demand charge, would be an estimated \$5.86 higher under the proposed TOU rate compared to the 2017 TY rates. For a 600 kWh monthly usage and 3.336 kW peak residential customer, their estimated monthly bill would be \$3.69 lower under the ARD rates compared to 2017 TY rates. This small difference would not affect the economic choice model DER uptake forecast in either direction for the average customer with the assumed average PV and battery system size. Stakeholders also commented that prospective DER customers looking toward purchasing a future EV may be dissuaded from adopting DER because of the potential impact of a large demand charge from vehicle charging. While a demand increase would lead to a higher demand charge under the Company’s proposed ARD rates, DER uptake would not necessarily be decreased under this scenario. The DER uptake model assumes a system size for PV and storage based on average customer usage. Introduction of an EV load would require adjusting the assumed

<sup>40</sup> See Hawaiian Electric’s Advanced Rate Design Initial Proposal filed on December 17, 2020 in Docket No. 2019-0323, Instituting a Proceeding to Investigate Distributed Energy Resource Policies pertaining to the Hawaiian Electric Companies.



PV and storage system size to account for the planned load increase, which ultimately adjusts the payback period.

As discussed in its Workplan update letter to the Commission filed on July 28, 2021, the Company is further evaluating TOU for non-DER and non-EV customers. The Company will provide an update on this issue no later than the October 1, 2021 Review Point filing.

However, the Company believes that the high and low bookend scenario already provides significant load shaping; for example, see Figure XX and Figure 4-5. Any impacts of increased demand charges or behavioral changes for customers without EV or DER will be captured within the bookends. The uncertainty of these and other future changes in customer trends are precisely what the bookends are intended to capture such that any changes that may occur, that impact the net demand, would fall within the bookends.

#### *High and Low Bookend Sensitivities*

To support the bookend scenarios, the Company sought additional feedback to derive assumptions for the DER sensitivities. At the June 17, 2020 STWG meeting, stakeholders provided comments on removing the addressable market constraints to account for the possibility for faster customer adoption and support the High DER sensitivity. As a result, the addressable market was expanded beyond to the Base case to include all existing NEM customers from 2021 through 2050. Additionally, the High DER sensitivity further extended the addressable market by removing the owner-occupied requirement, increasing the multi-family unit size threshold from 4 to 49 units, and included 100% of Schedule-P customers.

The Company also sought stakeholder feedback regarding future incentive structures. At the June 17, 2021 STWG meeting, the Company requested input on the possibility of extended tax credits and a longer-term export program. Stakeholders responded that both seem to be realistic possibilities. Although an extension of the Federal investment tax credit is still unknown with the current information available on the bipartisan infrastructure plan, the Company extended the Federal investment tax credit through 2032, with residential investment tax credits ending and commercial investment tax credits settling at 10% in 2033. The long-term upfront incentives for future grid services program on all islands were also increased to \$500/kW for the high DER forecast.

At the June 2, 2021 STWG meetings, stakeholders commented on the advancement of technology and supply chains that may drive down the costs of DER systems. In response, the Company used NREL 2021 ATB – Advanced Scenario cost curves for residential and commercial PV and battery systems for the High DER sensitivity forecast. The ATB – Advanced Scenario assumes a rapid advancement in technology innovation and manufacturing at levels above and beyond the current market. Resulting from the ATB – Advanced Scenario are more aggressive PV and battery system costs curves compared to the ATB – Moderate Scenario.



The Company re-purposed the previous July 2020 IGP base/market DER forecast as the Low DER sensitivity and as the basis for the No State ITC sensitivity. The No State ITC sensitivity was modeled assuming a 0% State ITC starting in 2022, resulting in lower DER uptake compared to the market forecast. In both sensitivities, DER system costs and tax credit assumptions were updated similarly to the current Base case, as shown in Table 4.2.

As a direct result of stakeholder input, Figure 4-1, below illustrates the revised DER forecasts.

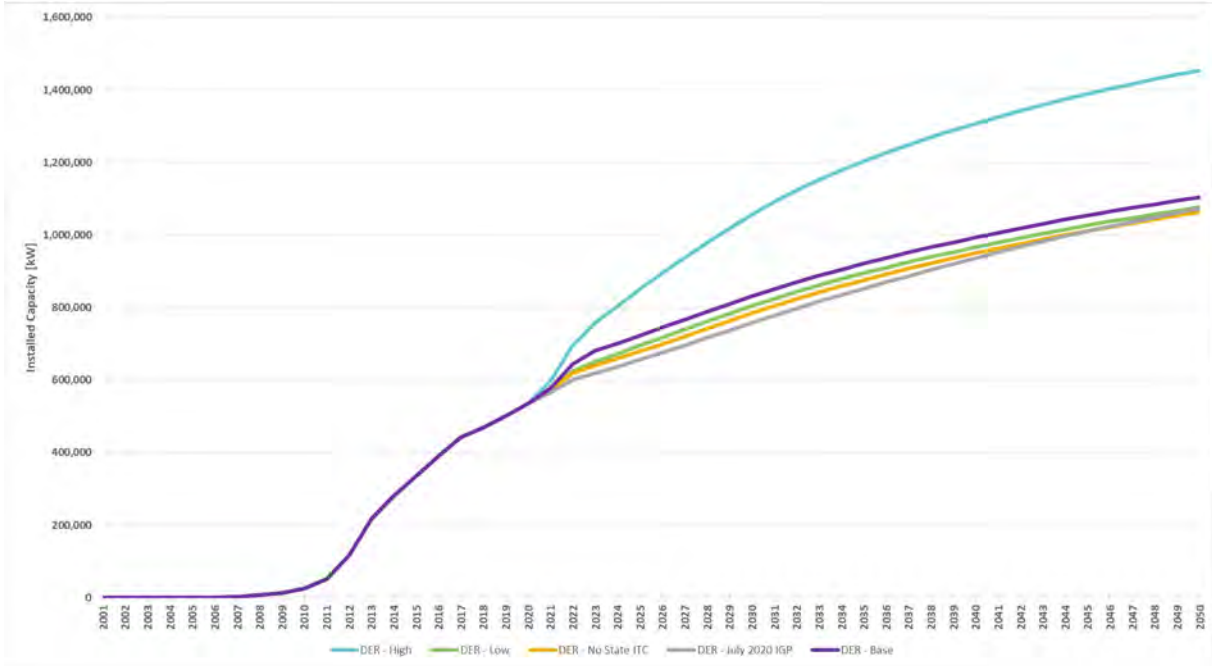

Figure 4-1: O’ahu DER Bookend Sensitivities

#### 4.1.2 Energy Efficiency

The energy efficiency layer is based on projections from the July 2020 State of Hawaii Market Potential Study prepared by Applied Energy Group (AEG) and sponsored by the Hawai’i Public Utilities Commission.<sup>41</sup> The preliminary results from the study were presented to the FAWG on January 29, 2020.<sup>42</sup> The market potential study considered customer segmentation, technologies and measures, building codes and appliance standards as well as the progress towards achieving the Energy Efficiency Portfolio Standards. The study included technical, economic, and achievable energy efficiency potentials.

<sup>41</sup>See <https://puc.hawaii.gov/wp-content/uploads/2021/02/Hawaii-2020-Market-Potential-Study-Final-Report.pdf>

<sup>42</sup> See [https://www.hawaiielectric.com/documents/clean\\_energy\\_hawaii/integrated\\_grid\\_planning/stakeholder\\_engagement/working\\_groups/forecast\\_assumptions/20200129\\_wg\\_fa\\_hawaii\\_market\\_potential\\_study\\_draft\\_results.pdf](https://www.hawaiielectric.com/documents/clean_energy_hawaii/integrated_grid_planning/stakeholder_engagement/working_groups/forecast_assumptions/20200129_wg_fa_hawaii_market_potential_study_draft_results.pdf)



An achievable Business As Usual (BAU) energy efficiency potential forecast by island and sector covering the years 2020 through 2045 was provided to the Company in February 2020 to use for the Company’s forecasts. The BAU potential forecast represented savings from realistic customer adoption of energy efficiency measures through future interventions that were similar in nature to existing interventions. In addition to the BAU forecast, AEG provided a codes and standards (C&S) forecast and an Achievable – High forecast . The Achievable - High potential forecast assumed higher levels of savings and participation through expanded programs, new codes and standards, and market transformation.

The forecasts provided to the Company reclassified certain market segments to different customer classes to align with how the Company forecasts sales. Since a thirty-year forecast was needed, the Company extended the forecast out to 2050 using trends in AEG’s forecast. AEG’s forecast for Lāna‘i and Moloka‘i was adjusted to be consistent with Hawaii Energy’s historical island allocation. A five year average net-to-gross ratio from Hawaii Energy’s program years 2014 through 2018 for each island was applied to the forecasts in order to exclude free riders<sup>43</sup> from the energy savings estimates as impacts from free riders were assumed to be embedded in the underlying forecasts described above. The impacts from AEG were derived at an annualized level and included free riders which reflected savings for all measures as if they were all installed in January and provided savings for the whole year. The annualized impacts were ramped throughout the year to arrive at energy efficiency impacts by month for each forecasted year. For simplicity, the installations were assumed to be evenly distributed throughout the year.

*High and Low Bookend Sensitivities*

The additional energy efficiency potentials provided by AEG allowed for the creation of various forecast sensitivities. As a result, the Company developed three different sensitivities, Low, High, and Freeze. These sensitivities were presented on July 9, 2021 with a smaller group of stakeholders and at the July 14, 2021 STWG meeting. The following Table 4.12 and Figure 4-2 summarize the energy efficiency sensitivities and their forecasted annual sales [GWh].

Table 4.12: Energy Efficiency Bookend Sensitivities

Low	Base	High	Freeze
BAU only	BAU + C&S	Achievable High + C&S	Forecasted capacity fixed at 2021 Base forecast

<sup>43</sup> A free rider is someone who would install an energy efficient measure without program incentives.



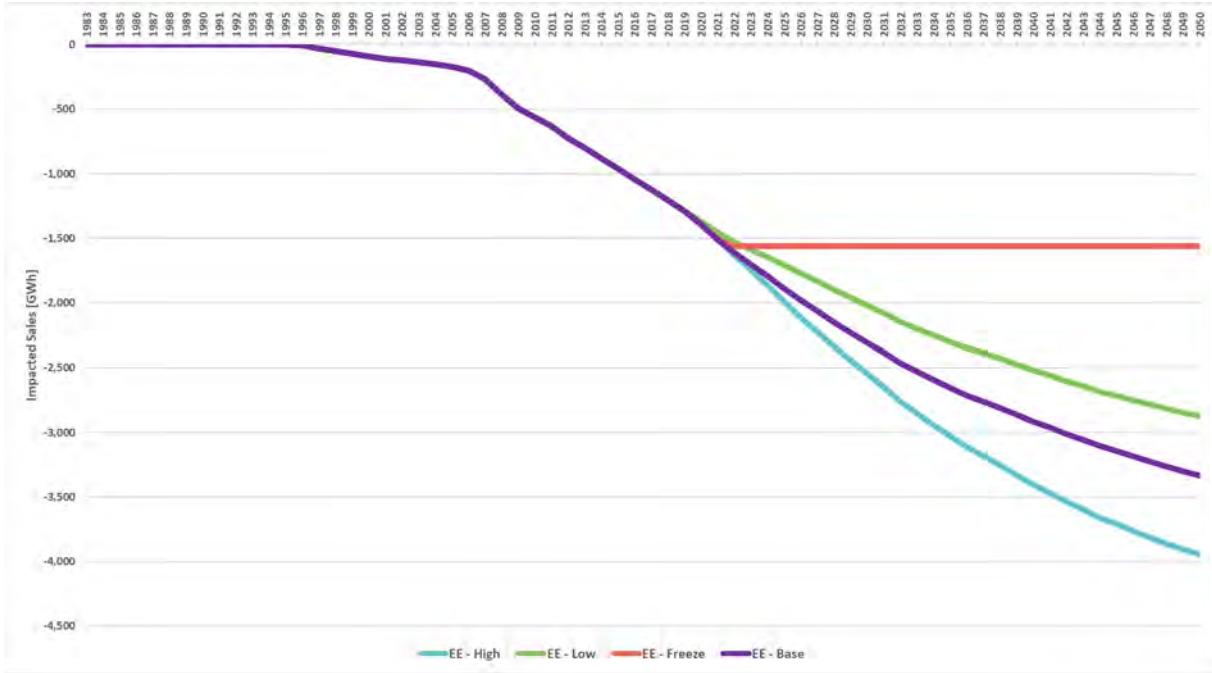

Figure 4-2: O’ahu Energy Efficiency Annual Sales Forecast Impact Sensitivities

As summarized in Section 2.2, the Company has already met with AEG to discuss the scope of work to bundle energy efficiency measures into resource options for selection by RESOLVE, in addition to and separate from the minimum uptake of energy efficiency that is assumed through the forecast layers. Draft supply curves for the energy efficiency resources will be shared with stakeholders once developed.

### 4.1.3 Electrification of Transportation

The electrification of transportation layer consists of impacts from the charging of light duty electric vehicles and electric buses.

#### *Light Duty Electric Vehicles*

The light duty electric vehicle forecast was based on an adoption model developed by Integral Analytics, Inc. as described in Appendix E of the EoT Roadmap<sup>44</sup> to arrive at EV saturations of total light duty vehicles (LDV) by year for each island. Historical data for LDV registrations were provided by the Department of Business, Economic Development, and Tourism (DBEDT) and reported at the county level. In order to get to the island level for Maui County, an allocation factor supplied by DBEDT and based on vehicle registration for the three islands was used. The total LDV forecast for each county was estimated using

<sup>44</sup> See [https://www.hawaiielectric.com/documents/clean\\_energy\\_hawaii/electrification\\_of\\_transportation/201803\\_eot\\_roadmap.pdf](https://www.hawaiielectric.com/documents/clean_energy_hawaii/electrification_of_transportation/201803_eot_roadmap.pdf)





a regression model driven by population and jobs based on UHERO’s October 2019 economic forecast. The development of the EV forecast utilized the EV saturation by island as shown on tab “EV Saturation” in Attachment 8 of PUC-HECO-IR-1 and applied the saturation to the LDV forecast for each island to arrive at the number of light duty EVs.<sup>45</sup> Although EV saturations were not specifically consistent with carbon neutrality in Hawaii by 2045, they are consistent with County goals for 2035.

To estimate the sales impact from EV charging for each island, the annual kWh used per vehicle was calculated based on the following equation:

$$\text{Annual kWh per vehicle} = \frac{(\text{Annual VMT} * (\text{kWh per mile})) * 10^6}{\text{Total LDV Forecast}}$$

where

- *Annual VMT* is the annual vehicle miles travelled
- *kWh per mile* is a weighted average of fuel economies of electric vehicles registered

*Annual VMT* is forecasted by applying the baseline economic growth rate developed by the Federal Highway Administration for light duty vehicles to DBEDT’s reported vehicle miles travelled for each county.<sup>46</sup> For Lāna‘i and Moloka‘i, vehicle miles travelled were developed based on information from DBEDT and on-island sources.

Historical *kWh per mile* was obtained using the weighted average fuel economy of registered electric vehicles by island. For Lāna‘i and Moloka‘i, the fuel economy from the Nissan Leaf represented each island’s average. Fuel economy and vehicle registration by type data were obtained from the U.S. Department of Energy’s Office of Energy Efficiency and Renewable Energy and Electric Power Research Institute (EPRI), respectively<sup>47</sup>. *Annual kWh per vehicle* was forecasted by applying a reference growth rate developed using the U.S. Energy Information Administration’s (EIA) Annual Energy Outlook to the historical weighted average fuel economies.<sup>48</sup> The reference fuel economy growth rate was developed based on the expectation that battery technology will improve and larger vehicles will be produced.

<sup>45</sup> See

[https://www.hawaiielectric.com/documents/clean\\_energy\\_hawaii/integrated\\_grid\\_planning/stakeholder\\_engagement/working\\_groups/forecast\\_assumptions/PUC-HECO-IR-1\\_att\\_8\\_electric\\_vehicles.xlsx](https://www.hawaiielectric.com/documents/clean_energy_hawaii/integrated_grid_planning/stakeholder_engagement/working_groups/forecast_assumptions/PUC-HECO-IR-1_att_8_electric_vehicles.xlsx)

<sup>46</sup> See [https://www.fhwa.dot.gov/policyinformation/tables/vmt/vmt\\_forecast\\_sum.pdf](https://www.fhwa.dot.gov/policyinformation/tables/vmt/vmt_forecast_sum.pdf)

<sup>47</sup> See <http://www.fueleconomy.gov>

<sup>48</sup> See <https://www.eia.gov/outlooks/aeo/data/browser/#/?id=113-AEO2019&cases=ref2019&sourcekey=0>



Car registration data at the ownership level was not available to determine whether a car was a personally or commercially owned vehicle. Therefore, the Company used a ratio between residential and commercial PV installations in historical years to allocate the number of EVs between residential and commercial customers for each island. EVs were a relatively new technology and the number of PV installations were found to be correlated to EV adoption. Within the commercial EVs, a percentage based on PV capacity installed by commercial rate Schedules G, J, and P was applied to the total commercial EV count to arrive at the number of EVs at the commercial rate schedule level. The sales impact by rate schedule was calculated by multiplying the number of EVs by sales impact per vehicle for each island.

### *Light Duty Electric Vehicles Charging Profiles*

Previous unmanaged charging profiles were developed using third party and public charging station telemetry, load research conducted by several utilities in California, as well as Hawaiian Electric specific advanced metering infrastructure (AMI) data. The unmanaged residential and commercial light duty electric vehicle charging profiles were updated by leveraging data from the Company's DC fast charging network and a case study<sup>49</sup> conducted through the deployment of EnelX's Level 2 chargers in Hawaii. Figure 4-3 below highlights the revised residential and commercial charging profiles compared to the previous IGP profiles, including a demand reduction during the evening peak hours in the residential charging profile. The revised charging profiles were presented on July 9, 2021 with a smaller group of stakeholders and again at the July 14, 2021 STWG meeting.

---

<sup>49</sup> See Smart Charge Hawai'i Case Study, In partnership with Hawaiian Electric & Elemental Excelsior, EnelX



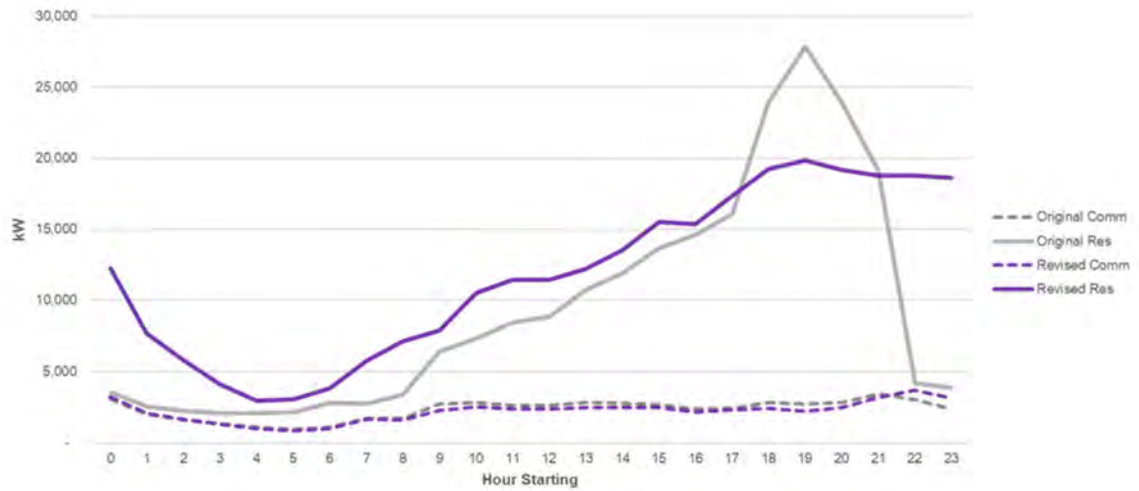

Figure 4-3: Revised Light Duty Electric Vehicle Charging Profiles

### Electric Buses

The electric bus forecast was based on information provided by the Company’s Electrification of Transportation team following discussions with several bus operators throughout Honolulu, Hawai’i and Maui counties. Route information and schedules for weekdays, weekends and holidays were used to estimate the miles traveled for each bus operator. Since specific information on the buses were not available for most operators, the Company used the average bus efficiency (kWh per mile) for two different Proterra models. For each island, the total sales impact for each bus operator was applied to the rate schedule on which each bus operator was serviced.

### High and Low Bookend Sensitivities

Three additional light duty electric vehicle forecast sensitivities (Low, High, and Freeze) were developed using varying adoption saturation curves. Low and high saturation curves were presented at the August 27, 2019 and January 20, 2020 FAWG meetings, with the low saturation curve implemented for the Low EV sensitivity. At the June 17, 2021 STWG meeting, Blue Planet presented their suggested sensitivity representing a policy of 100% zero emissions vehicles by 2045 in the high customer technology adoption bookend, a change from the previously presented high saturation curve. Following that meeting, Blue Planet provided two forecast scenarios as suggestive references for a 100% ZEV on the road scenario. The first was the Transcending Oil Report prepared by the Rhodium Group in 2018. The Transcending Oil Report study considered vehicle scrappage rates and the transition rate of vehicle sales to fully electric. The study estimated all vehicle sales by 2030 would need to be electric to reach 100% electric vehicle stock by 2045.<sup>50</sup> The

<sup>50</sup> See Transcending Oil Report by Rhodium Group available at: [https://rhg.com/wp-content/uploads/2018/04/rhodium\\_transcendingoil\\_final\\_report\\_4-18-2018-final.pdf](https://rhg.com/wp-content/uploads/2018/04/rhodium_transcendingoil_final_report_4-18-2018-final.pdf)



second was Blue Planet’s self-developed estimate using the State Energy Office’s Monthly Energy Trends data and a regression for the past 5 years on electric vehicle registrations. As discussed in Section 2.4 regarding areas of disagreement, Blue Planet most recently provided a revised high forecast that tracks closely with the Transcending Oil Report EV forecast. Ultimately, the High sensitivity used the 100% ZEV saturation scenario provided in the Transcending Oil Report. A freeze sensitivity was also developed, assuming no new additional electric vehicles above the Base forecast after 2021. These sensitivities were presented on July 9, 2021 with a smaller group of stakeholders and at the July 14, 2021 STWG meeting. The following table and figure summarize the light duty electric vehicle sensitivities and their forecasted annual sales [GWh].

Table 4.13: Electric Vehicle Forecast Sensitivities

Low	Base	High	Freeze
Low Adoption Saturation	Market Forecast	100% of ZEV by 2045	Forecasted EV counts fixed at 2021 Base forecast

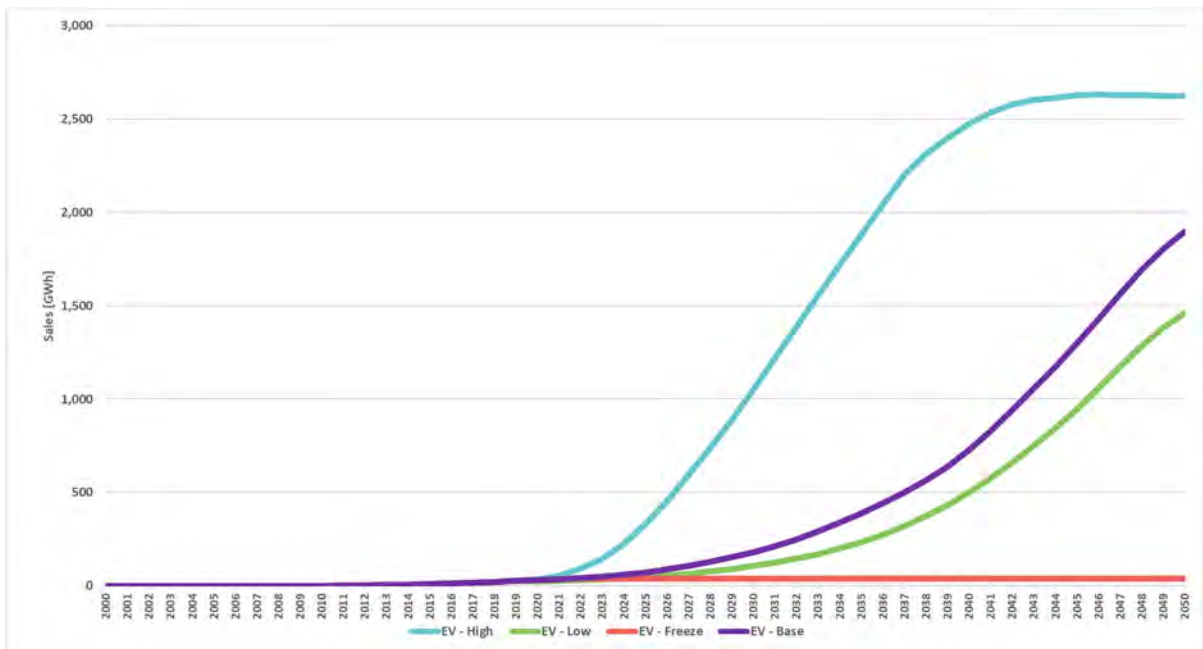

Figure 4-4: O’ahu Electric Vehicle Annual Sales Forecast Sensitivities

#### 4.1.4 Managed Electric Vehicle Charging

The managed electric vehicle charging profile considers EV driver response to time of use rates that were proposed for each island in the EV pilot programs in Docket No. 2020-0152. E3’s linear optimization was used to model drivers who shift their



usage in order to reduce their electricity bill as much as possible, while still retaining enough state of charge to meet their underlying driving profiles. The underlying trip data is the same so the managed and unmanaged charging have the same annual loads. The managed charging profiles from the I&A Review Point showed a flatter profile. E3 has since provided updated managed charging profiles based on their model, which shifts for of the charging load during the daytime. The updated average managed EV charging profile for select years is provided for O’ahu in Figure below.

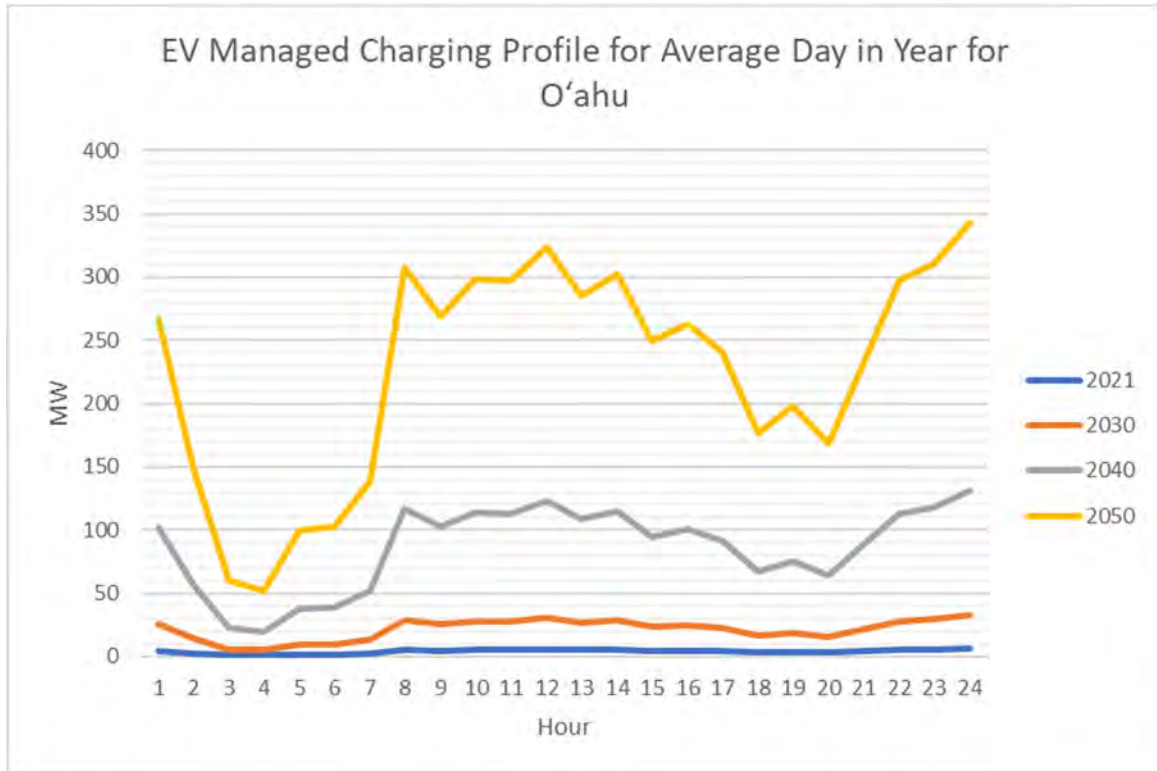

Figure 4-5: Average Managed EV Charging Profile for O’ahu

## 4.2 SALES FORECASTS

Once all the layers are developed for each island, they are added together to arrive at the sales forecast at the customer level by island as shown in the following tables.



Year	Underlying	Distributed Energy Resources (PV and BESS)	Energy Efficiency	Electric Vehicles	Customer Level Sales Forecast
GWH	A	B	C	D	E = A + B + C + D
2030	10,133	(1,415)	(2,307)	221	6,632
2045	11,499	(1,707)	(3,142)	1,366	8,016

Year	Underlying	Distributed Energy Resources (PV and BESS)	Energy Efficiency	Electric Vehicles	Customer Level Sales Forecast
GWH	A	B	C	D	E = A + B + C + D
2030	1,535	(263)	(345)	39	967
2045	1,670	(346)	(501)	288	1,110

Year	Underlying	Distributed Energy Resources (PV and BESS)	Energy Efficiency	Electric Vehicles	Customer Level Sales Forecast
GWH	A	B	C	D	E = A + B + C + D
2025	1,474	(271)	(300)	14	917
2030	1,572	(312)	(371)	56	945
2040	1,726	(374)	(473)	255	1,134
2045	1,787	(390)	(505)	357	1,248
2050	1,852	(403)	(529)	443	1,363



Year	Underlying	Distributed Energy Resources (PV and BESS)	Energy Efficiency	Electric Vehicles	Customer Level Sales Forecast
<b>GWH</b>	<b>A</b>	<b>B</b>	<b>C</b>	<b>D</b>	<b>E = A + B + C + D</b>
<b>2030</b>	36.4	(6.5)	(3.6)	0.3	26.6
<b>2045</b>	38.3	(8.0)	(4.5)	2.1	27.9

Year	Underlying	Distributed Energy Resources (PV and BESS)	Energy Efficiency	Electric Vehicles	Customer Level Sales Forecast
<b>GWH</b>	<b>A</b>	<b>B</b>	<b>C</b>	<b>D</b>	<b>E = A + B + C + D</b>
<b>2025</b>	40.8	(1.7)	(1.6)	0.1	37.6
<b>2030</b>	42.2	(2.1)	(2.0)	0.2	38.2
<b>2040</b>	44.1	(2.9)	(2.8)	0.7	39.1
<b>2045</b>	44.7	(3.2)	(3.0)	1.3	39.8
<b>2050</b>	45.6	(3.4)	(3.3)	1.9	40.8

The customer level sales forecasts were compiled by incorporating the separate layers for the underlying, distributed energy resources, energy efficiency, and electric vehicles sales. The Base forecast would incorporate the base forecast for each of the layers. In the Company’s proposal for Customer Technology Adoption bookends, the high layers would be added together to create a high bookend. Similarly, the low layers would be added together to create a low bookend. This process would incorporate layers that have offsetting effects on sales i.e. high DER and EE layers would reduce sales and offset the increased sales of the high EV layer. When compiling the sales layers, separate sales forecasts were also developed to incorporate a combination of layers that purposefully lead to high and low sales. In the charts below, the High and Low Customer Technology Adoption sales forecasts are shown in teal and green, labeled as High Adoption and Low Adoption, respectively. Separately, the high and low load sales forecasts are shown in shades of orange, labeled as High Load and Low Load, respectively.

Upon review of these sales forecasts, the Low Customer Technology Adoption bookend was observed to track the Base forecast and was not significantly



different to serve as a bookend. Similarly, the High Customer Technology Adoption bookend was observed to cross over the Low Customer Technology Adoption bookend and Base forecasts and would not serve as an appropriate bookend. However, the High Load and Low Load forecasts were significantly different from the Base forecasts, did not cross over other forecasts, and captured the High and Low Customer Technology Adoption forecasts within its bounds, making them a better candidate to serve as bookends. The selection of the High Load and Low Load scenarios is consistent with the TAP's recommendation to test the sensitivity of models and resulting portfolios by running bookend scenarios that utilize the cumulative potential high and low load forecasts for each layer. Section 6 further describes the adjustments made to the high and low bookends.





High and Low Bookend Scenarios

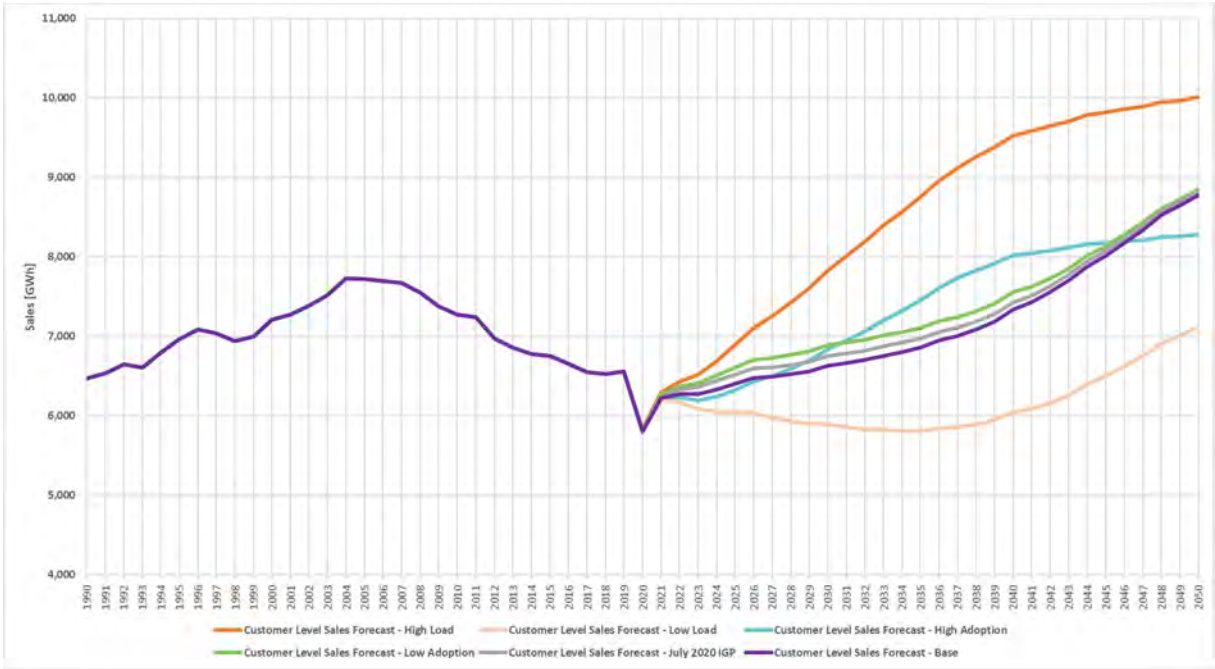

Figure 4-6: O'ahu Sales Forecast Bookend Sensitivities

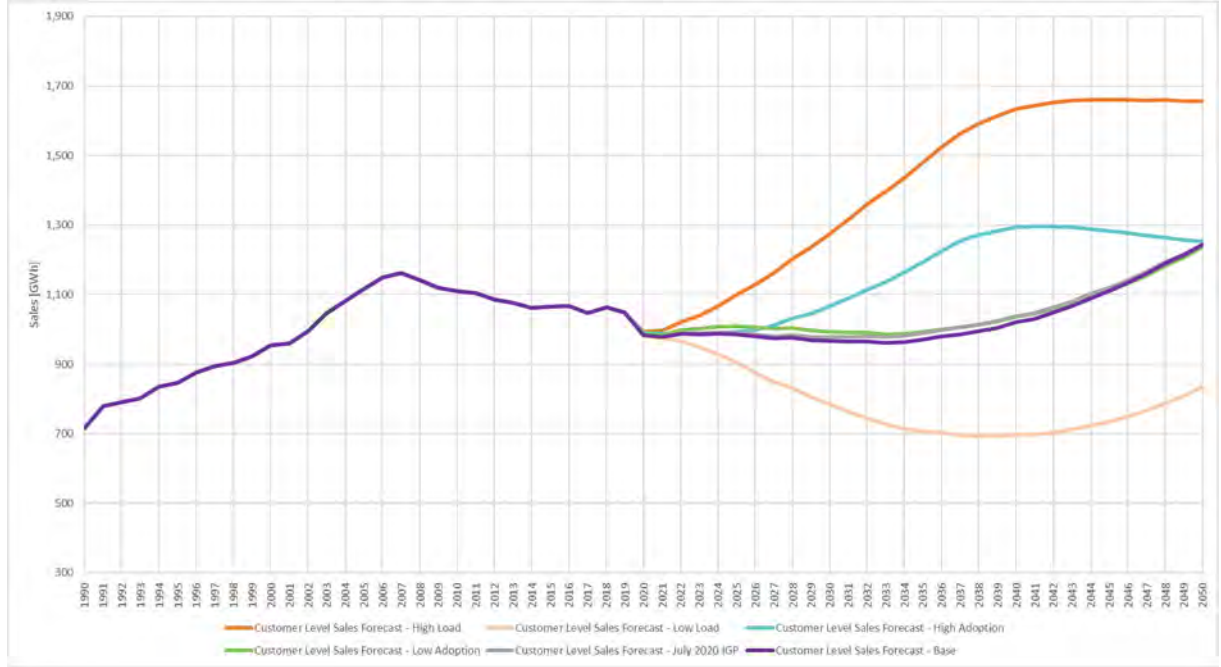

Figure 4-7: Hawai'i Island Sales Forecast Bookend Sensitivities

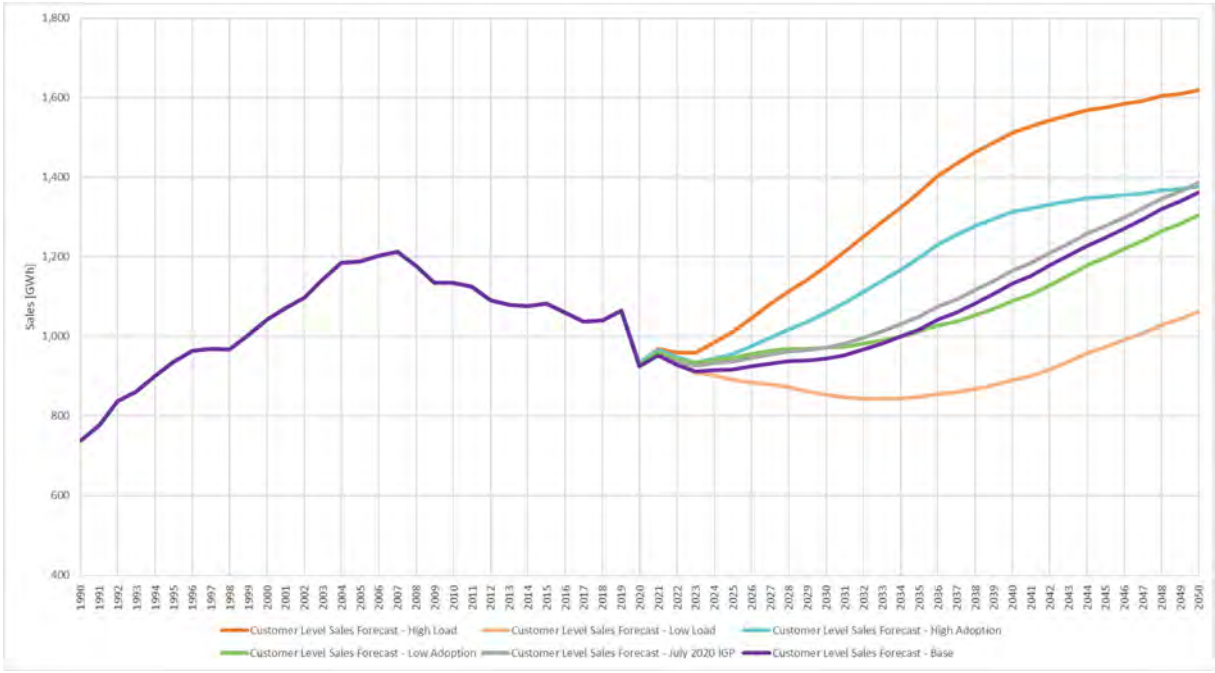

Figure 4-8: Maui Sales Forecast Bookend Sensitivities

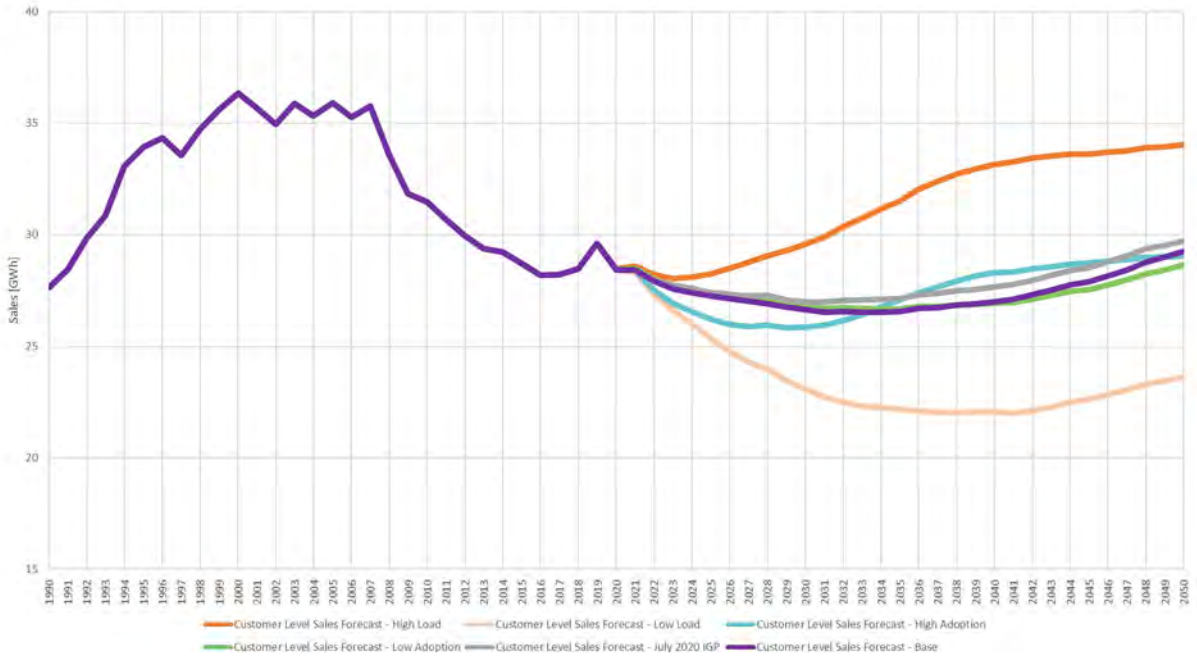

Figure 4-9: Moloka‘i Sales Forecast Bookend Sensitivities

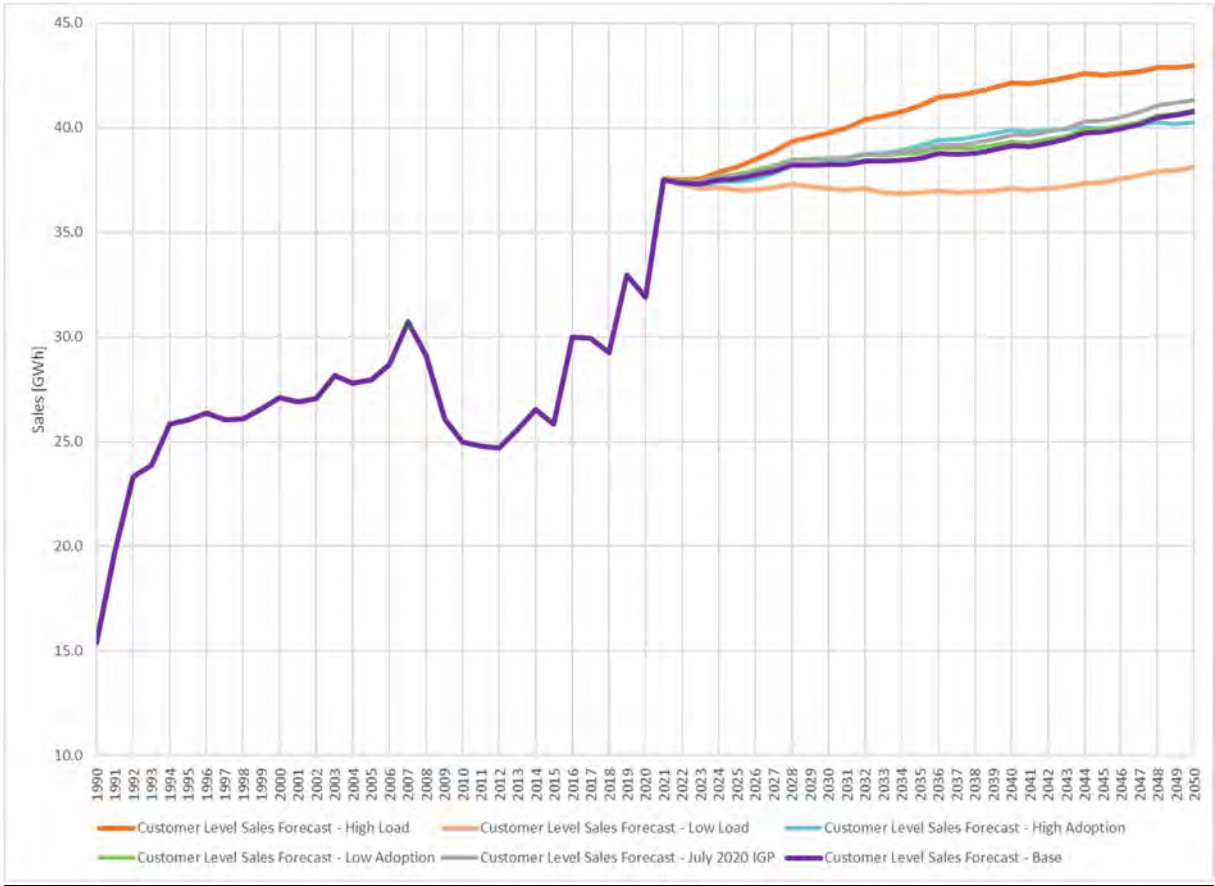

Figure 4-10: Lāna‘i Sales Forecast Bookend Sensitivities

### 4.3 PEAK FORECASTS

Once the sales forecast is developed by layer (underlying, DER, EE and EoT) for each island, it is converted from a monthly sales forecast into a load forecast at the system level for each hour over the entire forecast horizon. The method to do the conversion from sales to an hourly load forecast is shown in the figure below. Hourly shapes from class load studies (“CLS”) for each rate class or the total system load excluding the impact from PV are used to derive the underlying system load forecast shape. Hourly regression models are evaluated to look for relationships with explanatory variables (weather, month, day of the week, holidays) in order to accommodate change in the underlying shapes over time for each rate class or total system load. The hourly regression models are used to simulate shapes for the underlying forecast based on the forecast assumptions over



the entire horizon. The forecasted energy for the underlying and each adjusting layer (DER PV, battery load shift, energy efficiency and EoT) is placed under its respective future load shape then converted from the customer level to system level using a loss factor<sup>51</sup> as presented in the July 17, 2019<sup>52</sup> and March 9, 2020<sup>53</sup> FAWG meetings.

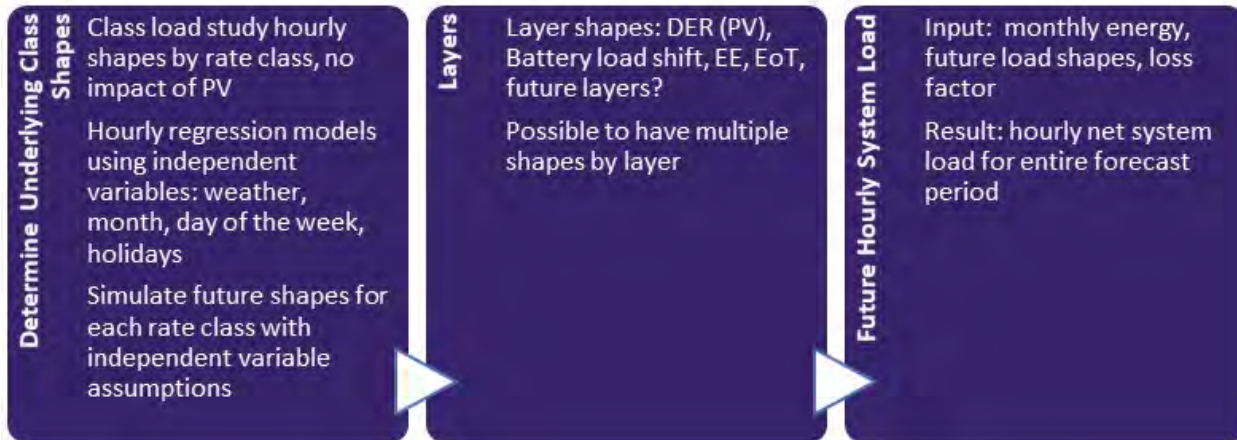

The result is an hourly net system load for the entire forecast period.

Once all the forecasted layers are developed by hour for each island, they are combined to arrive at an aggregated hourly load forecast. The annual peak forecast is the highest value in each year. The peaks presented in the August 31, 2020 FAWG meeting include the impacts of COVID-19.<sup>54</sup> This forecast assumes EVs will be charged at each owner’s convenience which may occur during the daytime on-peak period. This initial forecast will inform downstream processes in the development of programs and incentives related to shifting EV charging to off-peak periods. These programs and incentives will then be integrated into the forecast through an iterative process in the Grid Needs Assessment. As a result of this initial forecast which utilizes “unmanaged” charging, the peak contribution from EVs increases over time as EVs become more widely owned.

<sup>51</sup> The net-to-system factor used to convert customer sales to system level load is calculated as equal to 1/(1-loss factor) and include company use. The loss factors are included below: - Oahu: 4.43% - Hawaii: 6.76% - Maui: 5.17% - Lanai: 4.39% - Molokai: 9.07%

<sup>52</sup> See [https://www.hawaiianelectric.com/documents/clean\\_energy\\_hawaii/integrated\\_grid\\_planning/stakeholder\\_engagement/working\\_groups/forecast\\_assumptions/20190717\\_wg\\_fa\\_meeting\\_presentation\\_materials.pdf](https://www.hawaiianelectric.com/documents/clean_energy_hawaii/integrated_grid_planning/stakeholder_engagement/working_groups/forecast_assumptions/20190717_wg_fa_meeting_presentation_materials.pdf)

<sup>53</sup> See [https://www.hawaiianelectric.com/documents/clean\\_energy\\_hawaii/integrated\\_grid\\_planning/stakeholder\\_engagement/working\\_groups/forecast\\_assumptions/20200309\\_wg\\_fa\\_meeting\\_presentation\\_materials.pdf](https://www.hawaiianelectric.com/documents/clean_energy_hawaii/integrated_grid_planning/stakeholder_engagement/working_groups/forecast_assumptions/20200309_wg_fa_meeting_presentation_materials.pdf)

<sup>54</sup> See [https://www.hawaiianelectric.com/documents/clean\\_energy\\_hawaii/integrated\\_grid\\_planning/stakeholder\\_engagement/working\\_groups/forecast\\_assumptions/20200831\\_wg\\_fa\\_meeting\\_presentation\\_materials\\_HECO.pdf](https://www.hawaiianelectric.com/documents/clean_energy_hawaii/integrated_grid_planning/stakeholder_engagement/working_groups/forecast_assumptions/20200831_wg_fa_meeting_presentation_materials_HECO.pdf) and [https://www.hawaiianelectric.com/documents/clean\\_energy\\_hawaii/integrated\\_grid\\_planning/stakeholder\\_engagement/working\\_groups/forecast\\_assumptions/20200831\\_wg\\_fa\\_meeting\\_presentation\\_materials\\_HECO.pdf](https://www.hawaiianelectric.com/documents/clean_energy_hawaii/integrated_grid_planning/stakeholder_engagement/working_groups/forecast_assumptions/20200831_wg_fa_meeting_presentation_materials_HECO.pdf) See slides 7, 10, 12, 14 and 17 for O’ahu, Maui, Moloka’i, Lāna’i and Hawai’i islands respectively.



Year	Underlying	Distributed Energy Resources (PV and BESS)	Energy Efficiency	Electric Vehicles	Peak Forecast
MW	A	B	C	D	E = A + B + C + D
2030	1,642	(95)	(402)	39	1,184
2045	1,702	(43)	(452)	286	1,493

Table 4.20: Hawai'i Island Peak Forecast (MW)

Year	Underlying	Distributed Energy Resources (PV and BESS)	Energy Efficiency	Electric Vehicles	Peak Forecast
MW	A	B	C	D	E = A + B + C + D
2025	229.5	(10.0)	(42.6)	2.1	178.9
2030	236.8	(12.5)	(55.5)	8.7	177.5
2040	249.9	(10.8)	(84.2)	39.6	194.5
2045	247.2	(3.4)	(85.3)	64.5	223.1
2050	256.5	(3.8)	(99.6)	99.3	252.4

Table 4.21: Maui Peak Forecast (MW)

Year	Underlying	Distributed Energy Resources (PV and BESS)	Energy Efficiency	Electric Vehicles	Peak Forecast
MW	A	B	C	D	E = A + B + C + D
2025	246.7	(18.0)	(47.3)	2.2	183.6
2030	261.1	(29.2)	(58.1)	11.4	185.2
2040	241.4	(3.9)	(64.6)	63.3	236.2
2045	255.4	(4.1)	(67.7)	77.8	261.4
2050	260.3	(16.8)	(71.2)	111.5	283.8



Year	Underlying	Distributed Energy Resources (PV and BESS)	Energy Efficiency	Electric Vehicles	Peak Forecast
MW	A	B	C	D	E = A + B + C + D
2030	5.8	(0.1)	(0.2)	0.0	5.6
2045	6.3	(0.3)	(0.2)	0.5	6.3

Year	Underlying	Distributed Energy Resources (PV and BESS)	Energy Efficiency	Electric Vehicles	Peak Forecast
MW	A	B	C	D	E = A + B + C + D
2025	6.5	-	(0.1)	-	6.4
2030	6.8	(0.1)	(0.2)	-	6.6
2040	7.2	(0.1)	(0.3)	0.1	6.9
2045	7.3	(0.2)	(0.4)	0.3	7.0
2050	7.5	(0.2)	(0.4)	0.4	7.3

Similar to the customer level sales forecast, the peak forecast sensitivities were compiled by incorporating varying combinations of the underlying, distributed energy resources, energy efficiency, and electric vehicles hourly forecasts. The following chart includes the O’ahu peak forecast sensitivities that correspond to the customer sales level forecast sensitivities.





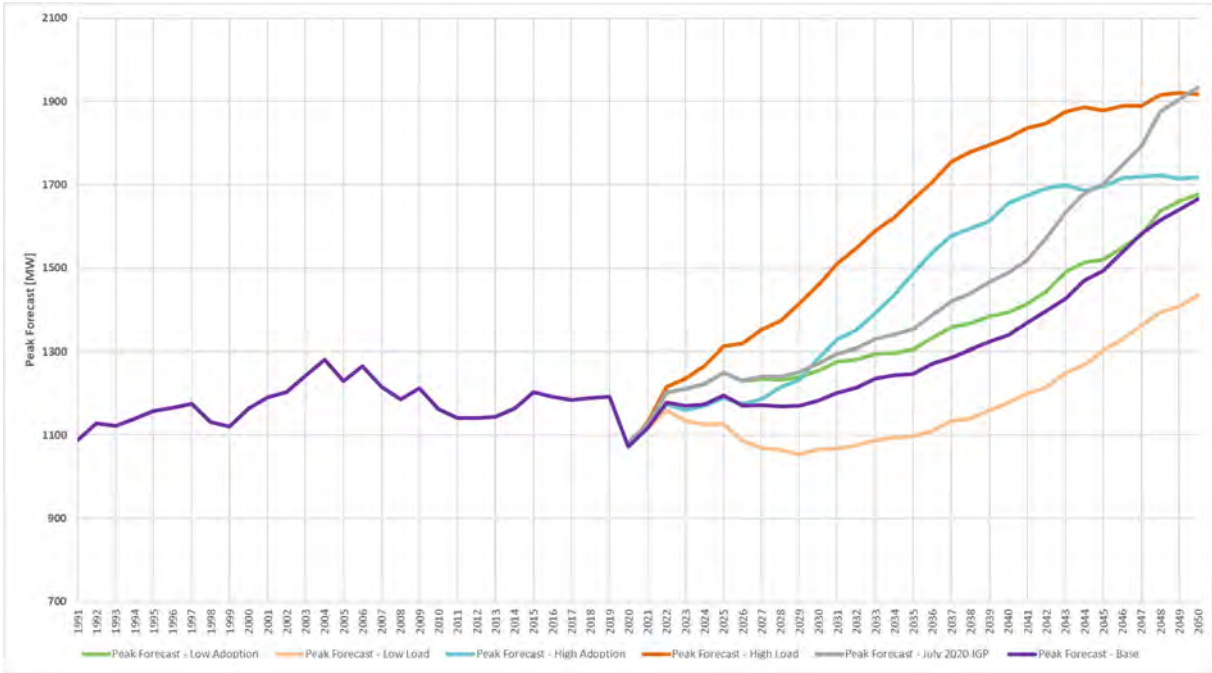

Figure 4-11: O’ahu Peak Forecast Bookend Sensitivities

#### 4.4 FUEL PRICE FORECASTS

The cost of producing electricity is dependent upon, in part, the cost of fuels utilized to generate power. Hawaiian Electric uses the following fuel types:

- Low Sulfur Fuel Oil (LSFO): A residual fuel oil similar to No. 6 fuel oil that contains less than 5,000 parts per million of sulfur; about 0.5% sulfur content
- No. 2 Diesel Oil
- Ultra-Low Sulfur Diesel (ULSD)
- Naphtha
- High Sulfur Fuel Oil (HSFO): Also called Industrial Fuel Oil (IFO), HSFO contains less than 2% sulfur

The fuel price forecast was developed using a correlation between historical, actual fuel prices and the Brent North Sea Crude Oil Benchmark (Brent) from 1983-2019.<sup>55</sup> The R<sup>2</sup> value for petroleum fuels was greater than 0.93. Hawaiian Electric’s 2021 forecast was based on the Brent forecast provided by the Energy Information Administration (“EIA”) Annual Energy Outlook (“AEO”).

<sup>55</sup> Hawaiian Electric updated its assumptions to use the fuel price forecast provided by the EIA AEO instead of FGE in response to stakeholder feedback to use publicly available, non-proprietary sources.



Table 4.24: O’ahu Fuel Price Forecast

Year	LSFO	Diesel	ULSD - CIP	ULSD - SGS	Biodiesel
2021	8.73	11.49	11.93	12.72	28.55
2022	9.43	12.24	12.71	13.51	29.32
2023	10.51	13.38	13.87	14.68	30.39
2024	11.36	14.28	14.80	15.62	31.37
2025	12.14	15.14	15.68	16.52	32.41
2026	13.03	16.11	16.68	17.54	33.60
2027	13.82	16.99	17.58	18.46	34.78
2028	14.67	17.94	18.56	19.46	36.04
2029	15.49	18.85	19.50	20.42	37.30
2030	16.36	19.82	20.49	21.45	38.60
2031	17.14	20.69	21.38	22.36	39.82
2032	18.03	21.67	22.40	23.40	41.12
2033	18.74	22.47	23.22	24.25	42.29
2034	19.47	23.29	24.07	25.11	43.45
2035	20.10	24.02	24.81	25.88	44.56
2036	20.90	24.90	25.72	26.82	45.77
2037	21.76	25.86	26.70	27.82	47.03
2038	22.63	26.82	27.69	28.83	48.31
2039	23.18	27.46	28.35	29.52	49.37
2040	24.37	28.76	29.69	30.88	50.91
2041	25.34	29.83	30.79	32.00	52.32
2042	26.15	30.75	31.74	32.98	53.65
2043	27.22	31.93	32.95	34.22	55.21
2044	28.16	32.99	34.04	35.34	56.73
2045	28.65	33.59	34.66	36.00	57.99
2046	29.99	35.08	36.19	37.56	59.92
2047	31.08	36.31	37.46	38.86	61.72
2048	32.03	37.40	38.59	40.03	63.49
2049	33.05	38.57	39.79	41.28	65.38
2050	34.10	39.79	41.05	42.57	67.35





Table 4.25: Hawai'i Island Fuel Price Forecast

Year	IFO	Diesel	ULSD	Naphtha	Biodiesel
2021	7.45	12.16	12.68	13.71	28.55
2022	8.06	12.98	13.52	14.50	29.32
2023	8.99	14.21	14.78	15.69	30.39
2024	9.72	15.18	15.78	16.65	31.37
2025	10.40	16.10	16.73	17.56	32.41
2026	11.17	17.15	17.81	18.61	33.60
2027	11.85	18.09	18.77	19.56	34.78
2028	12.59	19.11	19.82	20.58	36.04
2029	13.29	20.09	20.83	21.58	37.30
2030	14.05	21.13	21.91	22.63	38.60
2031	14.71	22.06	22.87	23.57	39.82
2032	15.48	23.13	23.96	24.64	41.12
2033	16.10	23.99	24.85	25.52	42.29
2034	16.72	24.86	25.75	26.41	43.45
2035	17.27	25.64	26.55	27.21	44.56
2036	17.96	26.59	27.53	28.17	45.77
2037	18.70	27.62	28.59	29.20	47.03
2038	19.45	28.65	29.65	30.24	48.31
2039	19.93	29.34	30.36	30.96	49.37
2040	20.96	30.74	31.80	32.35	50.91
2041	21.79	31.88	32.98	33.50	52.32
2042	22.50	32.87	34.00	34.51	53.65
2043	23.42	34.14	35.31	35.78	55.21
2044	24.23	35.28	36.48	36.94	56.73
2045	24.65	35.92	37.15	37.64	57.99
2046	25.81	37.52	38.79	39.24	59.92
2047	26.75	38.84	40.15	40.59	61.72
2048	27.57	40.01	41.37	41.81	63.49
2049	28.44	41.27	42.66	43.11	65.38
2050	29.35	42.57	44.01	44.46	67.35



Table 4.26: Maui County Fuel Price Forecast

Year	Maui				Moloka'i	Lāna'i
	IFO	Diesel	ULSD	Biodiesel	ULSD	ULSD
2021	7.09	11.75	12.09	28.55	12.91	16.08
2022	7.69	12.58	12.94	29.32	13.76	16.95
2023	8.62	13.85	14.23	30.39	15.04	18.26
2024	9.33	14.85	15.26	31.37	16.07	19.33
2025	10.00	15.78	16.22	32.41	17.03	20.35
2026	10.75	16.85	17.31	33.60	18.13	21.51
2027	11.42	17.80	18.28	34.78	19.12	22.58
2028	12.14	18.83	19.34	36.04	20.19	23.73
2029	12.83	19.82	20.36	37.30	21.22	24.84
2030	13.57	20.88	21.44	38.60	22.31	26.02
2031	14.22	21.82	22.40	39.82	23.29	27.08
2032	14.97	22.89	23.50	41.12	24.40	28.28
2033	15.57	23.76	24.39	42.29	25.31	29.27
2034	16.19	24.65	25.30	43.45	26.23	30.27
2035	16.72	25.43	26.10	44.56	27.05	31.17
2036	17.39	26.39	27.09	45.77	28.05	32.26
2037	18.12	27.43	28.15	47.03	29.12	33.41
2038	18.85	28.48	29.22	48.31	30.21	34.58
2039	19.31	29.16	29.93	49.37	30.93	35.39
2040	20.33	30.59	31.39	50.91	32.40	36.94
2041	21.14	31.75	32.58	52.32	33.60	38.23
2042	21.83	32.75	33.60	53.65	34.64	39.36
2043	22.73	34.03	34.92	55.21	35.97	40.79
2044	23.52	35.18	36.09	56.73	37.16	42.09
2045	23.93	35.81	36.74	57.99	37.84	42.90
2046	25.07	37.43	38.40	59.92	39.52	44.70
2047	25.98	38.76	39.76	61.72	40.90	46.22
2048	26.78	39.93	40.97	63.49	42.14	47.60
2049	27.63	41.19	42.26	65.38	43.46	49.07
2050	28.51	42.49	43.60	67.35	44.83	50.60



## 4.5 RESOURCE COST FORECASTS

Resource cost assumptions were based on publicly available datasets, as shown in Table 4.27.

Table 4.27: Resource Cost Data Sources

U.S. Department of Energy (DOE)	<ul style="list-style-type: none"> <li>Distributed wind<sup>56, 57</sup></li> <li>Pumped Storage Hydro<sup>58</sup></li> </ul>
National Renewable Energy Laboratory (NREL) <sup>59</sup>	<ul style="list-style-type: none"> <li>Grid-Scale PV</li> <li>Distributed PV</li> <li>Onshore Wind</li> <li>Geothermal</li> <li>Biomass</li> <li>Grid-Scale Storage</li> <li>Distributed Storage</li> <li>Combustion Turbine</li> <li>Combined Cycle</li> <li>Synchronous Condenser</li> <li>Offshore wind<sup>60</sup></li> </ul>
US Energy Information Administration (EIA) <sup>61</sup>	<ul style="list-style-type: none"> <li>Waste-to-energy</li> </ul>
Hawaiian Electric <sup>62</sup>	<ul style="list-style-type: none"> <li>ICE</li> </ul>

Resource cost assumptions began with a base technology capital cost that was adjusted for:

<sup>56</sup> U.S. Department of Energy, 2017 Distributed Wind Market Report, <https://www.energy.gov/eere/wind/downloads/2017-distributed-wind-market-report>

<sup>57</sup> U.S. Department of Energy, 2018 Distributed Wind Market Report, <https://www.energy.gov/eere/wind/downloads/2018-distributed-wind-market-report>

<sup>58</sup> U.S. Department of Energy, 2020 Grid Energy Storage Technologies Cost and Performance Assessment, <https://www.energy.gov/energy-storage-grand-challenge/downloads/2020-grid-energy-storage-technology-cost-and-performance#:~:text=Pacific%20Northwest%20National%20Laboratory%E2%80%99s%202020%20Grid%20Energy%20Storage,different%20cost%20categories%20of%20energy%20storage%20systems>.

<sup>59</sup> National Renewable Energy Laboratory 2021 Annual Technology Baseline, 2021 ATB Data, <https://atb.nrel.gov/electricity/2021/data>

<sup>60</sup> National Renewable Energy Laboratory Bureau of Ocean Energy Management, Cost Modeling for Floating Wind Energy Technology Offshore Oahu, Hawaii, <https://www.boem.gov/sites/default/files/documents/regions/pacific-ocs-region/environmental-analysis/HI%20Cost%20Study%20Fact%20Sheet.pdf>

<sup>61</sup> U.S. Energy Information Administration, Cost and Performance Characteristics of New Generating Technologies, Annual Energy Outlook 2019

<sup>62</sup> ICE costs are based on the Schofield Generating Station provided in Docket No. 2017-0213, in response to the Consumer Advocate’s information request number 19.



1. Future technology trends through the planning period;
2. Location-specific capital and O&M cost adjustments for Hawai'i; and
3. Applicable Federal & State tax incentives;
4. Price parity to recent renewable projects.

Figure 4-12 is a summary of the resource forecasts in nominal dollars. The resource cost forecasts from 2020-2050 can be found in Appendix A: Nominal Resource Cost Forecasts (2020 – 2050). In the near-term, there are price declines after accounting for the investment tax credit schedules for the Federal and State investment tax credits. Over the longer term, after the tax credit schedules ramp down and are held constant, the resources costs generally increase over time. As noted in the NREL ATB, all technologies include electrical infrastructure and interconnection costs for internal and control connections, onsite electrical equipment e.g. switchyard, power electronics and transmission substation upgrades.<sup>63</sup> Similarly, all technologies also include site costs for access roads, buildings for operation and maintenance, fencing, land acquisition, and site preparation in the capital expenditures as well as land lease payments in the fixed costs for O&M.<sup>64</sup> Although the ATB does not discretely break out the percentage of the capital costs or O&M costs associated with either of these items, their inclusion is consistent with the adjustment made for recent PV, wind, geothermal, and PV+BESS projects as actual project pricing would have accounted for interconnection and land costs.

---

<sup>63</sup> See <https://atb.nrel.gov/electricity/2021/definitions#capitalexpenditures>

<sup>64</sup> Ibid.



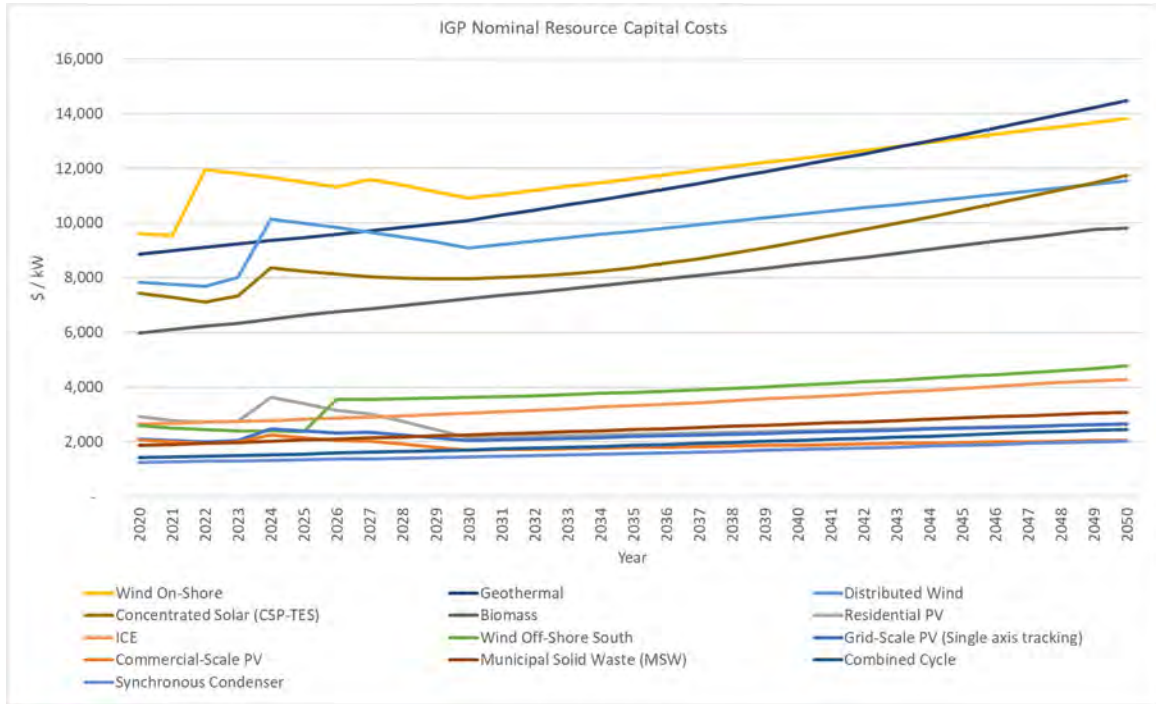

Figure 4-12: Capital Costs for IGP Candidate Resources

A comparison of the levelized cost of energy for select resources to the recently procured solar paired with storage PPAs<sup>65</sup> is shown below in Figure 4-13.

<sup>65</sup> See <https://www.hawaiianelectric.com/new-renewable-projects-submitted-to-regulators-will-produce-lower-cost-electricity-advance-clean-energy>



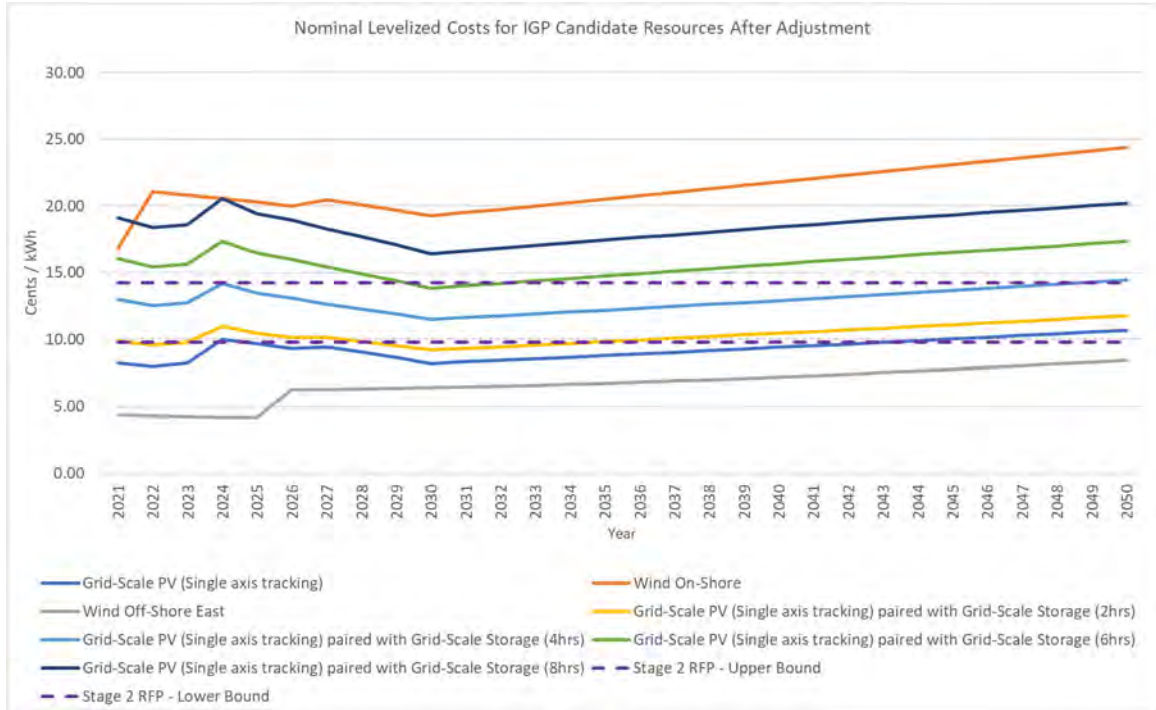

Figure 4-13: Levelized Cost of Energy for Select IGP Candidate Resources

### Photovoltaics (PV)

For Photovoltaics (PV), three different classes were forecasted: Grid-Scale PV, Commercial PV, and Residential PV. Each class used a similar process to develop the cost forecast.

#### Data Source

The source data for capital and fixed operations and maintenance (O&M) costs was provided by the 2021 NREL ATB. For Grid-Scale PV, the capital costs provided were in Real 2019 dollars  $\$/kW_{ac}$  and the O&M costs provided were in Real 2019 dollars  $\$/kW_{ac}$ -year. For Commercial and Residential PV, the capital costs provided were in Real 2019 dollars  $\$/kW_{dc}$  and the O&M costs provided were in Real 2019 dollars  $\$/kW_{dc}$ -year. The future trend for the capital and fixed O&M cost was derived from the 2021 NREL ATB projections. The Real 2019 dollars were converted to nominal dollars by applying an escalation factor of 2.3%.

#### Location Adjustment

A location adjustment factor was applied to convert both capital costs ( $\$/kW$ ) and O&M costs ( $\$/kW$ -year) to Hawai'i costs. A 63% location adjustment factor for



capital<sup>66</sup> was provided by the U.S. Energy Information Administration (EIA)<sup>67</sup> for Grid-Scale PV and a 62% location adjustment factor for Commercial and Residential PV. An 18.5% location adjustment factor for fixed O&M costs was provided by the RSMeans City Cost Index.<sup>68</sup>

**DC to AC Conversion**

Capital costs for Commercial and Residential PV were converted from \$/kW<sub>dc</sub> to \$/kW<sub>ac</sub>. For Commercial and Residential PV, a DC to AC conversion factor of 1.15 was used. These conversion factors were based on assumptions provided by NREL.

**Investment Tax Credit Adjustment**

The Federal<sup>69</sup> and State ITC<sup>70</sup> schedules assumed for PV are summarized in **Error! Reference source not found.** below. In December 2020, the Federal ITC for PV was given a two-year extension.<sup>71</sup> As a result, the capital cost for Grid-Scale PV, Commercial PV, and Residential PV were adjusted accordingly.

Table 4.28: Federal and State ITC Schedule for PV

Year	2020	2021	2022	2023	2024	2025	2026	2027	Future
Federal ITC for Grid-Scale and Commercial-Scale PV	26%	26%	26%	22%	10%	10%	10%	10%	10%
Federal ITC for Residential PV	26%	26%	26%	22%	0%	0%	0%	0%	0%
State ITC for Grid-Scale, Commercial and Residential PV	35%	35%	25%	25%	20%	20%	20%	15%	15%

**Recent Project Adjustment**

Final capital costs were adjusted based on actual costs from recent projects. For standalone PV, the cost was adjusted by approximately 162% so that the LCOE was similar to West Loch PV (7.5 cents / kWh). For paired PV, the costs were adjusted by approximately 106% so that the annual payment of the paired system would be similar to the lump sum payments of the Stage 2 projects that had a term of 25 years and a 4-hour Battery.

<sup>66</sup> A location cost variation percentage from the EIA Capital Cost Estimates for Utility Scale Electricity Generating Plants.

<sup>67</sup> See [https://www.eia.gov/analysis/studies/powerplants/capitalcost/pdf/capcost\\_assumption.pdf](https://www.eia.gov/analysis/studies/powerplants/capitalcost/pdf/capcost_assumption.pdf)

<sup>68</sup> RSMeans Building Construction Cost Data (BCCD) is a reference book for estimating construction costs in the U.S. and Canada.

<sup>69</sup> See <https://www.greentechmedia.com/articles/read/solar-and-wind-tax-credit-extensions-energy-rd-package-in-pending-bill-before-congress>

<sup>70</sup> See <https://tax.hawaii.gov/geninfo/renewable>

<sup>71</sup> See <https://www.greentechmedia.com/articles/read/solar-and-wind-tax-credit-extensions-energy-rd-package-in-pending-bill-before-congress>



## Onshore Wind

### Data Source

The source data for capital and fixed O&M costs for Onshore Wind was provided by the 2021 NREL ATB . The capital costs were in Real 2019 dollars \$/kW. The fixed O&M costs were in Real 2019 \$/kW-year. The future trend for the capital and O&M costs was derived from the 2021 NREL ATB projections. The Real 2019 dollars were converted to nominal dollars by applying an escalation factor of 2.3%.

### Location Adjustment

The capital costs were converted to Hawai'i costs using a 35% factor from EIA for wind technology. The O&M costs were converted to Hawai'i costs using an 18.5% RSMMeans factor. Location-specific interconnection costs were not included in the estimate.

### Investment Tax Credit Adjustment

The Federal<sup>72,73</sup> and State ITC<sup>74</sup> schedules assumed for Onshore Wind are summarized in Table below. Initially, the Federal ITC for Onshore Wind was to expire at the end of 2020.<sup>75</sup> In December 2020, however, the expiration date was extended a year.<sup>76</sup> As a result, the capital cost was for Onshore Wind was adjusted accordingly.

Table 4.29: Federal and State ITC Schedule for Onshore Wind

Year	2020	2021	2022	2023	2024	2025	2026	2027	Future
Federal ITC	18%	18%	0%	0%	0%	0%	0%	0%	0%
State ITC	20%	20%	20%	20%	20%	20%	20%	15%	15%

### Recent Project Adjustment

Final capital costs were adjusted based on actual costs from recent projects. For Onshore Wind, the costs were adjusted by approximately 772% so that the LCOE was similar to Na Pua Makani (15.3 cents / kWh).

<sup>72</sup> <https://www.energy.gov/sites/prod/files/2020/02/f71/weto-funding-factsheet-2020.pdf> and <https://www.greentechmedia.com/articles/read/solar-and-wind-tax-credit-extensions-energy-rd-package-in-spending-bill-before-congress>

<sup>73</sup> <https://www.greentechmedia.com/articles/read/solar-and-wind-tax-credit-extensions-energy-rd-package-in-spending-bill-before-congress>

<sup>74</sup> <https://tax.hawaii.gov/geninfo/renewable>

<sup>75</sup> <https://www.energy.gov/sites/prod/files/2020/02/f71/weto-funding-factsheet-2020.pdf> and <https://www.greentechmedia.com/articles/read/solar-and-wind-tax-credit-extensions-energy-rd-package-in-spending-bill-before-congress>

<sup>76</sup> <https://www.greentechmedia.com/articles/read/solar-and-wind-tax-credit-extensions-energy-rd-package-in-spending-bill-before-congress>





## Offshore Wind

### Data Source

The source data for the Offshore wind estimate was developed specially for Hawaii by NREL. The NREL study was used to determine the underlying costs for both capital and O&M.

### Location Adjustment

The capital costs and O&M cost provided by NREL were specifically tailored for Hawaii. Therefore, no location adjustment was needed. The location-specific onshore interconnection costs were not included in the estimate.

### Investment Tax Credit Adjustment

The Federal<sup>77</sup> and State ITC<sup>78</sup> schedules assumed for Offshore Wind are summarized in Table below. Initially, Offshore Wind followed the same schedule as Onshore Wind. In December 2020, the Federal ITC for Offshore Wind was developed.<sup>79</sup> As a result, the capital cost for Offshore Wind was adjusted accordingly.

Table 4.30: Federal and State ITC Schedule for Offshore Wind

Year	2020	2021	2022	2023	2024	2025	2026	2027	Future
Federal ITC	30%	30%	30%	30%	30%	30%	0%	0%	0%
State ITC	20%	20%	20%	20%	20%	20%	20%	15%	15%

## Distributed Wind

### Data Source

The capital and fixed O&M source data for distributed wind was provided by the Department of Energy's Distributed Wind Market Reports. The capital cost was provided in the Department of Energy's 2017 Distributed Wind Market Report.<sup>80</sup> Initially, capital costs in the report were interpreted to be in 2017 dollars. Upon further review, the costs provided in the report were stated in 2016 dollars. Resource costs for distributed wind stated in this document were then adjusted accordingly. The O&M cost were provided in the Department of Energy's 2018

<sup>77</sup> <https://www.greentechmedia.com/articles/read/solar-and-wind-tax-credit-extensions-energy-rd-package-in-spending-bill-before-congress>

<sup>78</sup> <https://tax.hawaii.gov/geninfo/renewable>

<sup>79</sup> <https://www.greentechmedia.com/articles/read/solar-and-wind-tax-credit-extensions-energy-rd-package-in-spending-bill-before-congress>

<sup>80</sup> As stated in the 2018 report, because of the extremely low number of small wind project records with installed cost data, a 2018 average cost analysis was not presented in the 2018 report.



Distributed Wind Market Report. Initially, O&M cost in the report were from the Department of Energy’s 2017 Wind Technologies Market Report, but were updated based on the 2018 Distributed Wind Market Report. The average installed small wind costs were used from these reports. These costs were converted to 2019 dollars using a fixed escalation rate of 2.3%. The future cost trend was estimated using the future cost projections from the 2021 NREL ATB for land-based wind.

**Location Adjustment**

The U.S. benchmark cost was converted to Hawai’i costs for capital and O&M cost estimates. A 35% EIA factor for wind technology was applied for the capital cost conversion to Hawai’i. An 18.5% RSMean factor was used to convert fixed O&M costs to Hawai’i costs. Location-specific interconnection costs were not included in the estimate.

**Investment Tax Credit Adjustment**

The Federal<sup>81,82</sup> and State ITC<sup>83</sup> schedules assumed for Distributed Wind are summarized in Table below. In December 2020, the Federal ITC was given a two-year extension.<sup>84</sup>

Table 4.31: Federal and State ITC for Distributed Wind

Year	2020	2021	2022	2023	2024	2025	2026	2027	Future
Federal ITC	26%	26%	26%	22%	0%	0%	0%	0%	0%
State ITC	20%	20%	20%	20%	20%	20%	20%	15%	15%

*Biomass*

**Data Source**

The source data for Biomass capital, fixed O&M, and variable O&M costs as well as Biomass fuel sources were provided by the 2021 NREL ATB for dedicated biomass technology. The capital costs, O&M costs, and fuel costs were given in Real 2019 dollars. The Real 2019 costs were converted to nominal dollars by applying an escalation factor of 2.3%.

**Location Adjustment**

Nominal capital, O&M and fuel costs for Biomass were converted to Hawai’i costs. The capital costs were converted using a 46% EIA factor. The O&M and fuel costs

<sup>81</sup> <https://www.law.cornell.edu/uscode/text/26/48>

<sup>82</sup> <https://rules.house.gov/sites/democrats.rules.house.gov/files/BILLS-116HR133SA-RCP-116-68.pdf>

<sup>83</sup> <https://tax.hawaii.gov/geninfo/renewable>

<sup>84</sup> See <https://www.greentechmedia.com/articles/read/solar-and-wind-tax-credit-extensions-energy-rd-package-in-spending-bill-before-congress>



were converted to Hawaii using an 18.5% RSMeans factor. Location-specific interconnection costs were not included in the estimate.

### *Pumped Storage Hydro*

#### **Data Source**

The source data for Pumped Storage Hydro capital, fixed O&M, and variable O&M costs were provided by the Department of Energy and the Pacific Northwest National Laboratory for a 100 MW, 10 hour duration resource. Capital costs and O&M costs were given in 2020 dollars. Future costs were assumed to increase at an escalation rate of 2.3%.

#### **Location Adjustment**

A 45% EIA factor for CT technology was used to convert the capital costs to Hawai'i costs and an 18.5% RSMeans factor was used to convert the fixed O&M and variable O&M costs to Hawai'i costs. Location-specific interconnection costs were not included in the estimate.

### *Combustion Turbine and Combined Cycle with Synchronous Condenser Function*

#### **Data Source**

The source data for Combustion Turbine (CT) and Combined Cycle (CC) capital, fixed O&M, and variable O&M costs as well as fuel sources were provided by the 2021 NREL ATB forecast. The capital costs, O&M costs, and fuel costs were given in Real 2019 dollars. The Real 2019 costs were converted to nominal dollars by applying an escalation factor of 2.3%.

#### **Location Adjustment**

A 45% EIA factor for CT and CC technology was used to convert the capital costs to Hawai'i costs and an 18.5% RSMeans factor was used to convert the fixed O&M and variable O&M costs to Hawai'i costs. Location-specific interconnection costs were not included in the estimate.

### *Concentrated Solar Power (CSP)*

#### **Data Source**

The source data for Concentrated Solar Power (CSP) capital, fixed O&M, and variable O&M costs was provided by the 2021 NREL ATB. Capital costs and O&M costs were given in Real 2019 dollars. The Real 2019 costs were converted to nominal dollars by applying an escalation factor of 2.3%.

#### **Location Adjustment**

A 62% EIA factor for PV was used as an approximation to convert capital costs to Hawai'i costs. The federal and state investment tax credit schedule was assumed to be the same as grid scale PV. Fixed and variable O&M costs were converted to



Hawai'i costs using an 18.5% RSMears factor. Location-specific interconnection costs were not included in the estimate.

**Investment Tax Credit Adjustment**

The Federal<sup>85</sup> and State ITC<sup>86</sup> schedules assumed for CSP are summarized in Table below. Initially, there were no Federal or State ITC assumed for CSP. After additional consideration, it was determined that a CSP system should be considered as a system that uses solar energy to generate electricity. As a result, CSP should receive the Federal and State ITC. The latest Federal and State ITC were applied, and the capital cost was adjusted.

Year	2020	2021	2022	2023	2024	2025	2026	2027	Future
Federal ITC	26%	26%	26%	22%	10%	10%	10%	10%	10%

*Geothermal*

**Data Source**

The source data for the Geothermal capital, fixed and variable O&M were provided by the 2021 NREL ATB for Geothermal geo-hydro binary technology. The capital costs, O&M costs and fuel costs in ATB were given in Real 2019 dollars and converted to nominal dollars by applying an escalation factor of 2.3%.

**Location Adjustment**

A 20% EIA factor for Geothermal technology was used to convert capital costs to Hawai'i costs. Fixed O&M and variable O&M costs used an 18.5% RSMears factor. Location-specific interconnection costs were not included in the estimate.

**Investment Tax Credit Adjustment**

The following federal tax credit schedule<sup>87</sup> was assumed for Geothermal technology.

Table 4.33: Federal and State ITC for Geothermal

Year	2020	2021	2022	2023	2024	2025	2026	2027	Future
Federal ITC	10%	10%	10%	10%	10%	10%	10%	10%	10%

<sup>85</sup> <https://www.greentechmedia.com/articles/read/solar-and-wind-tax-credit-extensions-energy-rd-package-in-spending-bill-before-congress>

<sup>86</sup> <https://tax.hawaii.gov/geninfo/renewable>

<sup>87</sup> <https://programs.dsireusa.org/system/program/detail/658>



State ITC	0%	0%	0%	0%	0%	0%	0%	0%	0%
-----------	----	----	----	----	----	----	----	----	----

**Recent Project Adjustment**

Final capital costs were adjusted based on actual costs from the current PGV contract and amended contract application provided in Docket No. 2019-0333. For Geothermal, the costs were adjusted by approximately 141% based on an average LCOE of the current (16.4 cents / kWh) and amended contract (11.4 cents / kWh), calculated using the minimum purchase requirement from the amended contract and historical annual payments made to PGV under the current contract.

*Internal Combustion Engine (ICE)*

**Data Source**

The source data to estimate Internal Combustion Engine (ICE) technology was informed by actual costs for the Schofield Generating Station project constructed on O’ahu. The cost estimates were escalated from 2017 dollars by applying an escalation factor of 2.3%. The future cost trend was estimated using the cost trend for gas CT technology discussed above due to limited information on a future ICE capital cost trend.

*Municipal Solid Waste (MSW)*

**Data Source**

The Municipal Solid Waste (MSW) source data was based on the U.S. Energy Information Administration Cost and Performance Characteristics of New Generating Technologies Annual Energy Outlook for 2019. The costs were adjusted from 2018 dollars to 2019 dollars by applying an escalation factor of 2.3%. The future cost projections were estimated using future cost trend from Biomass technology discussed above due to limited information on future MSW capital cost trend.

**Location Adjustment**

A 20% EIA factor for Biomass technology was used as an approximation to convert capital costs. Fixed O&M and variable O&M costs were converted to Hawai’i costs using an 18.5% RSM means factor.

*Battery Energy Storage*

**Data Source**

The source data for Grid-Scale and Residential Battery Energy Storage Systems (BESS) was provided in the 2021 NREL ATB. Both the Balance of System cost, provided in \$/kW, and the Module costs, provided in \$/kWh, were in provided in Real 2019 dollars. Embedded interconnection cost was removed from the



estimate. The Real 2019 costs were converted to nominal dollars by applying an escalation factor of 2.3%.

#### **Location Adjustment**

The capital costs for Balance of System and Modules were converted to Hawai'i costs using a 32% EIA factor. Fixed O&M and variable O&M costs were converted to Hawai'i costs using an 18.5% RSMeans factor.

#### **Pairing Adjustment**

Paired storage capital costs were adjusted based on the PV tax credit schedule. Because the State tax credit has a dollar cap, the State tax credit applied to paired storage is the difference between the cap and the amount already applied to the PV system.

#### **Recent Project Adjustment**

Final capital costs were adjusted based on actual costs from recent projects. For standalone BESS, the costs were adjusted by approximately 105% so the annual payment would be similar to the lump sum payments for the Kapolei Energy Storage System. For paired BESS, the costs were given the same adjustment as the paired PV, as described earlier.

#### *Synchronous Condenser*

#### **Data Source**

The cost projections were estimated using Combustion Turbine technology discussed above due to limited information on Synchronous Condenser capital cost in the 2021 NREL ATB. Cost for conversion of existing generators to synchronous condensers will be considered on a case-by-case basis.



## 5 Resource Potential and Renewable Energy Zones

The first year available for each of the candidate resources that can be selected in RESOLVE reflects typical development timelines to bring the resource online. The first year available varies by resource and is summarized in the table below. Planned resources will be built according to their commercial operations date before 2025.

Table 5.1: First Year Available for Candidate Resources

Resource Type	First Year Available
Grid-Scale PV	2025
Onshore Wind	2025
Battery Energy Storage	2025
Synchronous Condenser	2025
Offshore Wind	2028-2030
ICE	2028-2030
Combustion Turbine	2028-2030
Combined Cycle	2028-2030
Biomass	2028-2030
Geothermal	2028-2030

### 5.1 NREL SOLAR AND WIND RESOURCE POTENTIAL STUDY UPDATE

NREL utilized their Renewable Energy Potential Model (reV) to assess the potential for solar and wind energy deployment. The solar and wind resource data sets will be sourced from the National Solar Radiation Database and the Hawaii WIND toolkit. The NSRDB has a temporal interval of 30-minutes and nominal spatial resolution of 4 km. The WIND toolkit has an hourly temporal interval with a nominal spatial resolution of 2 km. The model will consider land exclusions such as slope, man-made structures, protected areas, and land cover. System configurations can also be considered in the model such as axis tracking, losses, tilt, panel type, inverter efficiency, and DC/AC ratio.

The NREL Resource Potential Study will also include PV rooftop potential analysis, which will rely upon Light Detection and Ranging (LiDAR) data. The model will consider LiDAR point clouds, buildings, solar resource from the NSRDB, parcels, and tree canopy. The system configurations can also be considered such as, fixed roof, losses, tilt, azimuth, panel type, module efficiency, inverter efficiency, and DC/AC ratio.



The NREL Resource Potential Study can be found online<sup>88</sup> as part of the August 18, 2020 Stakeholder Council meeting materials. Table 5.2 below summarizes the original scenarios modeled in the NREL Resource Potential Study.

Table 5.2 Summarized installable capacity in MW for grid-scale 1-axis tracking PV systems all scenarios; Lands with capacity factors >= 0.10

Island	PV 1-3	PV 1-5	PV-1 HS	PV 2-3	PV 2-5	PV-2 HS	PV 3-3	PV 3-5
O'ahu	907	1,954	9,634	1,412	2,794	13,965	561	1,008
Moloka'i	1,225	3,016	13,387	1,225	3,016	13,387	1,177	2,918
Maui	1,038	2,669	26,728	1,038	2,669	26,728	508	1,411
Lāna'i	697	1,478	9,599	697	1,478	9,599	557	1,199
Hawai'i	12,417	29,384	117,231	15,083	35,319	129,977	13,621	31,841

Based on feedback from Ulupono, the Company requested NREL to include updated scenarios for 15% and 30% slope development, among other changes to inputs. Table 5.3 **Error! Reference source not found.**, below, shows the revised potentials based on Ulupono's input. PV-Alt-2 and PV-Alt-4, include Department of Defense lands. PV-Alt 1 and PV-Alt-2 use a threshold of 30% slope land and PV-Alt-3 and PV-Alt-4 use a threshold of up to 15%.

Table 5.3 Summarized installable capacity in MW for grid-scale 1-axis tracking PV systems up to 15% and 30% slope land; Input assumptions based on Ulupono input

Island	PV-Alt-1	PV-Alt-2	PV-Alt-3	PV-Alt-4
O'ahu	3,810	7,026	1,405	2,932
Moloka'i	10,411	10,411	7,107	7,107
Maui	13,687	13,687	6,613	6,613
Lāna'i	9,691	9,691	6,330	6,330
Hawai'i	76,179	89,470	62,198	74,751

<sup>88</sup> See

[https://www.hawaiianelectric.com/documents/clean\\_energy\\_hawaii/integrated\\_grid\\_planning/stakeholder\\_engagement/stakeholder\\_council/20200818\\_sc\\_heco\\_tech\\_potential\\_final\\_report.pdf](https://www.hawaiianelectric.com/documents/clean_energy_hawaii/integrated_grid_planning/stakeholder_engagement/stakeholder_council/20200818_sc_heco_tech_potential_final_report.pdf)





Table 5.4 details the land exclusions assumptions used to determine the MW PV potentials, above.

Table 5.4 Land exclusion assumptions for PV potential scenarios

Exclusion Category	Land Category	PV								PV	PV	PV	PV
		PV-1-3	PV-1-5	PV-1-HS	PV-2-3	PV-2-5	PV-2-HS	PV-3-3	PV-3-5				
Federal Lands	National Guard	Include	Include	Include	Include	Include	Include	Include	Include	exclude	exclude	exclude	exclude
	National Park Service	Exclude	Exclude	Exclude	Exclude	Exclude	Exclude	Exclude	Exclude	exclude	exclude	exclude	exclude
	Other Federal Lands	Include	Include	Include	Include	Include	Include	Include	Include	exclude	exclude	exclude	exclude
	U.S. Department of Defense Lands	Exclude	Exclude	Exclude						exclude	include	exclude	include
State Parks	U.S. Fish & Wildlife Service												
	State Park												
	State Bird Sanctuary												
	State Cultural/Historic Area												
	State Ecological Reserve												
	State Estuary Reserve												
	State Game Land												
	State Game or Wildlife Sanctuary												
	State Monument												
	State Nature Preserve/Reserve												
	State Wildlife Mgmt. Area												
Dept. of Defense	Other State Lands												
Dept. of Defense	Dept. of Defense Lands	Exclude	Exclude	Exclude						exclude	include	exclude	include
Wetlands	Estuarine and Marine Deepwater												
	Estuarine and Marine Wetland												
	Fresh. Emergent Wetland												
	Fresh. Forested/Shrub Wetland												
	Fresh. Pond												
Lava flow	Lake												
	Riverine												
Flood Zones	Highest												
	Second Highest												
Flood Zones	Kilauea Lava Flow (2018)												
Ag Areas	"A"												
Ag Areas	Important Agricultural Lands (IAG)												
Urban Zones	Urban Areas												
	HCDA Oahu Affordable Housing Prj												
Slope	Slope percent > 3%	Exclude	Include	Include	Exclude	Include	Include	Exclude	Include	include	include	include	include
	Slope percent > 5%	Exclude	Exclude	Include	Exclude	Exclude	Include	Exclude	Exclude	include	include	include	include
	Slope percent > 10%	n/a	n/a	n/a	n/a	n/a	n/a	n/a	n/a	include	include	include	include
	Slope percent > 15%	n/a	n/a	n/a	n/a	n/a	n/a	n/a	n/a	cost addr	cost addr	exclude	exclude
	Slope percent > 20%	Exclude	Exclude	Include	Exclude	Exclude	Include	Exclude	Exclude	cost addr	cost addr	exclude	exclude
	Slope percent > 30%	n/a	n/a	n/a	n/a	n/a	n/a	n/a	n/a	exclude	exclude	exclude	exclude
Setbacks	Slope percent > 40%									exclude	exclude	exclude	exclude
	Road Setback (173m)									include	include	include	include
	Building Setback (173m)									include	include	include	include
Land Study Bureau Agricultural Lands	Transmission ROW Setback (173m)									include	include	include	include
	Class A Land	Include	Include	Include	Include	Include	Include	90% Exc.	90% Exc.	exclude	exclude	exclude	exclude
	Class B Land									90% Exc.	90% Exc.	10% Inc	10% Inc
Sea Level Rise	Class C Land									10% Inc	10% Inc	10% Inc	10% Inc
	SLR 1ft - 50yr									n/a	n/a	n/a	n/a
	SLR 1ft - 100yr									n/a	n/a	n/a	n/a
	SLR 1ft - 500yr									n/a	n/a	n/a	n/a
Tsunami Evacuations Zones	SLR 3.2 ft at 1 ft flood height - 100yr (majority pixels)	n/a	n/a	n/a	n/a	n/a	n/a	n/a	n/a	exclude	exclude	exclude	exclude
	Tsunami Evacuation Zones	Exclude	Exclude	Exclude	Exclude	Exclude	Exclude	Exclude	Exclude	include	include	include	include
RE Development Zones	Extreme Tsunami Evacuation Zones	Include	Include	Include	Include	Include	Include	Include	Include	include	include	include	include
	Oahu, Molokai, Hawaii (x2)	Include	Include	Include	Include	Include	Include	Include	Include	include	include	include	include
Oahu Land Use Ordinance - Urban Zones	A-1, A-2, A-3, Aloha, AMX-1, AMX-2, AMX-3, Apart, ApartMix, B-1, B-2, BMX-3, BMX-4, I-1, I-2, I-3, IMX-1, Kak, MU, PU, Pub, R-10, R-20, R-3.5, R-5, R-7.5, ResMix, Resort, WI	Exclude	Exclude	Exclude	Exclude	Exclude	Exclude	Exclude	Exclude	exclude	exclude	exclude	exclude
Private Land Use	Golf Courses	n/a	n/a	n/a	n/a	n/a	n/a	n/a	n/a	exclude	exclude	exclude	exclude

Table 5.5, below, shows the original wind potential scenarios modeled.



Table 5.5 Summarized installable capacity in MW for grid-scale wind systems all scenarios; Lands with Wind speeds  $\geq 6.5$  m/s

Island	Wind-1-20	Wind-1-HS	Wind-2-20	Wind-2-HS	Wind-3-20	Wind-3-HS	Wind-4-20	Wind-4-HS
<b>O'ahu</b>	436	761	640	1,147	230	465	333	728
<b>Moloka'i</b>	951	1,249	951	1,249	688	958	688	958
<b>Maui</b>	634	940	634	940	421	659	421	659
<b>Lāna'i</b>	381	441	381	441	312	368	312	368
<b>Hawai'i</b>	1,189	1,254	1,189	1,254	982	1,039	982	1,039

Table 5.6, below, shows the updated wind scenarios based on Ulupono's input. Wind-Alt-2 includes Department of Defense land. Both Wind-Alt-1 and Wind-Alt-2 cut off wind speeds as 6.5 m/s as in the original wind scenarios, above.

Table 5.6 Summarized installable capacity in MW for grid-scale wind systems up to 15% slope land; Input assumptions based on Ulupono input

Island	Wind-Alt-1	Wind-Alt-2
<b>O'ahu</b>	186	284
<b>Moloka'i</b>	515	515
<b>Maui</b>	278	278
<b>Lāna'i</b>	305	305
<b>Hawai'i</b>	670	670

Table 5.7 details the land exclusions assumptions used to determine the wind potentials, above.



Table 5.7 Land exclusion assumptions for wind potential scenarios

Exclusion Category	Land Category	Wind								Wind	Wind
		WIND-1-20	WIND-1-40	WIND-2-20	WIND-2-40	WIND-3-20	WIND-3-40	WIND-4-20	WIND-4-40	Wind-Alt-1	Wind-Alt-2
Federal Lands	National Guard	include	include	include	include	include	include	include	include	exclude	exclude
	National Park Service	Exclude	Exclude	Exclude	Exclude	Exclude	Exclude	Exclude	Exclude	exclude	exclude
	Other Federal Lands	include	include	include	include	include	include	include	include	exclude	exclude
	U.S. Department of Defense Lands	Exclude	Exclude			Exclude	Exclude			exclude	include
	U.S Fish & Wildlife Service										
State Parks	State Park										
	State Bird Sanctuary										
	State Cultural/Historic Area										
	State Ecological Reserve										
	State Estuary Reserve										
	State Game Land										
	State Game or Wildlife Sanctuary										
	State Monument										
	State Nature Preserve/Reserve										
	State Wildlife Mgmt. Area										
Other State Lands											
Dept. of Defense	Dept. of Defense Lands	Exclude	Exclude			Exclude	Exclude			exclude	include
Wetlands	Estuarine and Marine Deepwater										
	Estuarine and Marine Wetland										
	Fresh. Emergent Wetland										
	Fresh. Forested/Shrub Wetland										
	Fresh. Pond										
	Lake										
Lava flow	Riverine										
	Highest										
	Second Highest										
Flood Zones	Kilauea Lava Flow (2018)										
Ag Areas	Important Agricultural Lands (IAG)										
Urban Zones	Urban Areas										
	HCDA Oahu Affordable Housing Prj										
Slope	Slope percent > 3%	include	include	include	include	include	include	include	include	include	include
	Slope percent > 5%	include	include	include	include	include	include	include	include	include	include
	Slope percent > 10%	n/a	n/a	n/a	n/a	n/a	n/a	n/a	n/a	include	include
	Slope percent > 15%	n/a	n/a	n/a	n/a	n/a	n/a	n/a	n/a	include	include
	Slope percent > 20%	Exclude	Include	Exclude	Include	Exclude	Include	Exclude	Include	exclude	exclude
	Slope percent > 30%	n/a	n/a	n/a	n/a	n/a	n/a	n/a	n/a	exclude	exclude
Setbacks	Slope percent > 40%	Exclude	Exclude	Exclude	Exclude	Exclude	Exclude	Exclude	Exclude	exclude	exclude
	Road Setback (173m)	include	include	include	include					exclude	exclude
	Building Setback (173m)	include	include	include	include					exclude	exclude
	Transmission ROW Setback (173m)	include	include	include	include					exclude	exclude
Land Study Bureau Agricultural Lands	Class A Land									include	include
	Class B Land									include	include
	Class C Land									include	include
Sea Level Rise	SLR 1ft - 50yr									n/a	n/a
	SLR 1ft - 100yr									n/a	n/a
	SLR 1ft - 500yr									n/a	n/a
	SLR 3.2 ft at 1 ft flood height - 100yr (majority pixels)	n/a	n/a	n/a	n/a	n/a	n/a	n/a	n/a	exclude	exclude
Tsunami Evacuations Zones	Tsunami Evacuation Zones	Exclude	Exclude	Exclude	Exclude	Exclude	Exclude	Exclude	Exclude	exclude	exclude
	Extreme Tsunami Evacuation Zones	include	include	include	include	include	include	include	include	include	include
RE Development Zones	Oahu, Molokai, Hawaii (x2)	include	include	include	include	include	include	include	include	include	include
Oahu Land Use Ordinance - Urban Zones	A-1, A-2, A-3, Aloha, AMX-1, AMX-2, AMX-3, Apart, ApartMix, B-1, B-2, BMX-3, BMX-4, I-1, I-2, I-3, IMX-1, Kak, MU, PU, Pub, R-10, R-20, R-3.5, R-5, R-7.5, ResMix, Resort, WI	Exclude	Exclude	Exclude	Exclude	Exclude	Exclude	Exclude	Exclude	exclude	exclude
Private Land Use	Golf Courses	n/a	n/a	n/a	n/a	n/a	n/a	n/a	n/a	exclude	exclude

### 5.1.1 Solar and Wind Potential Assumption for IGP

The grid-scale solar and wind potential assumption garnered much discussion amongst stakeholders, with varying perspectives on what can realistically be built due to land use and community issues.



On the developable resource potential for onshore grid-scale solar and wind, the Company received stakeholder feedback that Federal contracting rules would require that the Department of Defense (“DoD”) seek the highest and best use for properties under their control, in addition to deciding whether that land would be made available for renewable energy development. Because of this circumstance, it would be difficult to make a blanket assumption that all DoD lands are available to develop. Further, stakeholders raised concerns on the ease of developing projects at slopes higher than 10% due to the additional work and cost involved. However, other stakeholders felt that higher slopes could be developed, up to 30%, with some additional cost adder. Because some projects have already been developed on steeper slopes.

Taking into consideration the various viewpoints, the Company will use the Alt-1 scenario for wind and solar potential for various scenarios. The Company will also use this Alt-1 scenario in developing transmission infrastructure needed to develop renewable energy zones, as discussed in the following Section 5.2. The Alt-1 scenario excludes DoD lands but includes development on land with slopes up to 30%.

It is worth noting that there is substantial overlap between areas with solar resource potential and wind resource potential. And the same system infrastructure can be used to interconnect both wind and solar resources and transfer the renewable energy to the other locations of the system.

However, the Company also recognizes the realities of solar and wind development in the State. To that end, a “Land Constrained” Scenario will reflect the possibility of future limited land availability for solar, wind development and provide a meaningful bookend of analysis that incorporates stakeholder feedback to assume a lower amount of land is available for project development.

---

## 5.2 RENEWABLE ENERGY ZONES

Hawaiian Electric has commenced a study to identify transmission infrastructure necessary to accommodate the large blocks of grid-scale renewable energy on the islands of O‘ahu, Maui, and Hawai‘i Island. The objective of this study is to assess the technical feasibility and needs to interconnect high amounts of renewable energy. The study is just one step in the transmission REZ planning process which is shown in Figure 5-1. The Company expects multiple iterations with stakeholder and communities as the process progresses. In this update, key assumptions for this analysis are listed in following sections, as well as a preliminary update on the progress made thus far. This is the Company’s first Renewable Energy Zones (REZ) study and will be included in its Grid Needs Review Point (scheduled for filing on October 1, 2021).



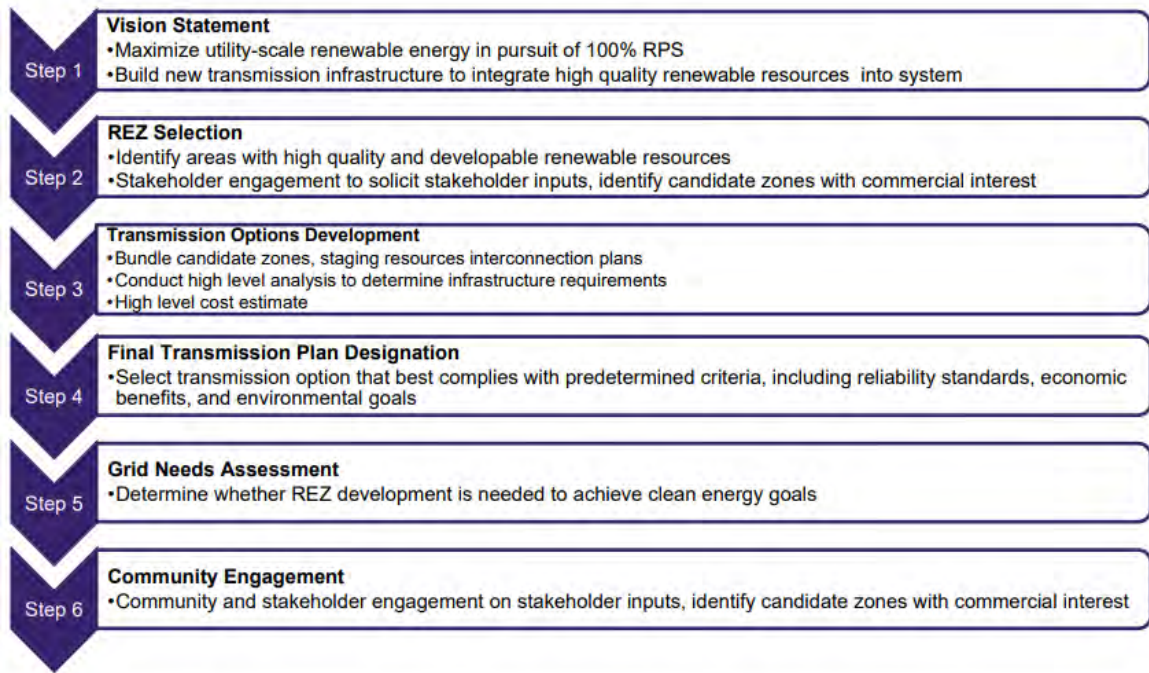

Figure 5-1: Transmission Renewable Energy Zone Planning Process

The study will allow the Company and stakeholders to get an initial understanding of the transmission upgrade options to accommodate future amounts of grid-scale renewable energy, which will be used within the IGP process; including developing future resource costs and schedules, and educating and engaging with communities to gather feedback on these potential plans. As an example, there are high amounts of solar potential on the west and north ends of O’ahu; however, there are currently no transmission lines in those areas. Creating a REZ by bringing out transmission lines to these areas would facilitate further development of renewable energy. These transmission requirements and cost to interconnect various renewable energy zones will serve as an input into the RESOLVE model. The RESOLVE model will then be allowed to select a specific renewable energy zone based on the cost of the solar or wind and associated transmission in that zone.

The study, based on steady-state power flow analyses, assesses the capacity of the existing transmission system and identifies the cost of different transmission upgrade options to interconnect the identified megawatt capacity of each renewable energy zones. The NREL potential study (Scenario Alt-1) described in Section 5.1.1 will be used as an initial target for capacity within the identified zones. The Company acknowledges there are differing opinions from stakeholders regarding these assumptions; however, for purposes of this study, the scenario provides an appropriate energy target to determine the transmission requirements.

The study will identify technology agnostic transmission requirements (i.e., major transmission lines and substations) necessary to facilitate the transfer of power from the REZ to the rest of the system. Costs for interconnection requirements that



are developed by specific projects are not included in this analysis (i.e., generation-tie lines).

While Figure 5-1 illustrates the overall REZ process, the general steps to complete the REZ study for the Grid Needs Review Point filing is shown in Figure 5-2.

In this report, the identified REZs based on NREL study results and grouping of REZs for each island are described. In Step 2, the forecasted load for the year 2040 is used to create the power flow study cases for this study.

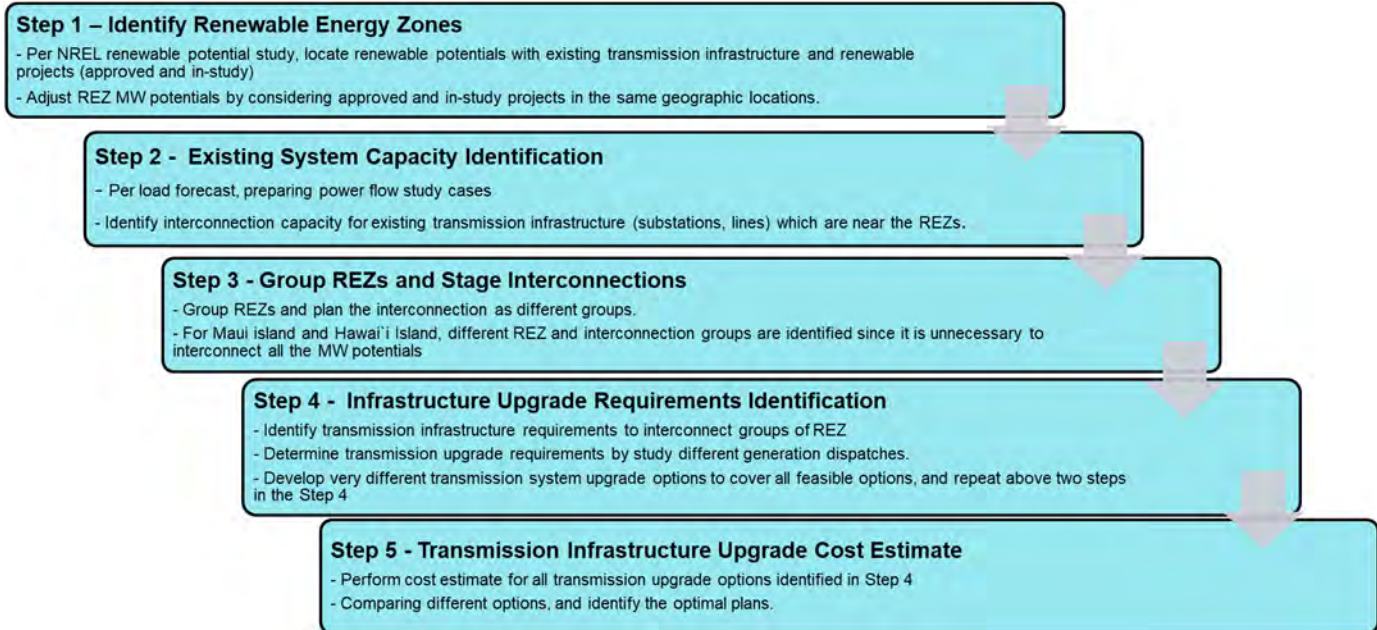

Figure 5-2: Transmission Renewable Energy Zone Study Procedures

The REZ concept was presented to the STWG on July 16, 2021. Hawaiian Electric walked through an illustrative analysis of steps 2-3 of Figure 5-1 for O'ahu to garner discussion and feedback. Stakeholders provided the following comments and feedback:

- Incorporate 150MW pumped storage hydro resource in Lake Wilson.
- Include a Community Engagement step earlier in the process.
- Incorporate the updated NREL study (e.g., Alt-1 Scenario) for REZ selection.
- What if the NREL study is overestimating the developable solar?
- In Wahiawa area, Hawaiian Electric was required to bury powerlines due to community concerns.
- Need to take into account transmission routes through conservation lands. EIS/EIA requirements will make new transmission lines difficult to achieve.
- Incorporate capacity requirements to accommodate off-shore wind resources based on BOEM study.





- New 138 kV lines or conversions from 46 kV along the North Shore area should be relocated outside of flood zones.
- Wind resources will mainly be available on the Kahe ridge and Kahuku mountains.
- The Company completed a Land RFI a few years ago which was helpful for developers to understand the available land and interconnections.
- The Company could model transmission between zones as separate investments within RESOLVE.
- The Company could consider awarding RFPs based on location.

Between the presentation on July 16, 2021 and the time of this filing, the Company has completed initial steps in the REZ study. Updates to the O’ahu, Maui, and Hawai’i Island REZs, utilizing the updated NREL scenario Alt-1 are provided below. The Company will provide its final report in the upcoming Grid Needs Review Point, scheduled for October 1, 2021.

*O’ahu Transmission REZs – Preliminary Update*

According to the NREL study report, the potential Mega Watts (“MW”) of grid-scale PV (white circles) and wind (green circles) on O’ahu island is shown as left and right figures in Figure 5-3.

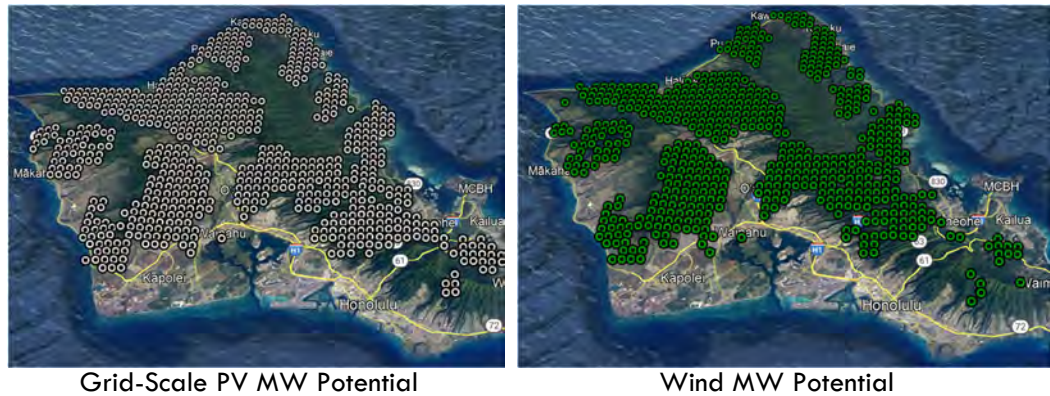

Figure 5-3: Grid-scale PV and Wind MW Potential on O’ahu Island

On O’ahu, the total grid-scale PV MW potential is 3,810 MW and total wind MW potential is 256 MW. Considering the is large overlap between zones with grid-scale potential and zones with wind potential, and the total wind MW potential is much smaller than the total grid-scale PV MW potential, the grid-scale PV zones identified in the NREL report is used for identifying transmission renewable energy zones and related transmission upgrade.

The grid-scale PV MW potential located on O’ahu is shown in Figure 5-4. The capacity of each zone was adjusted to subtract the capacity of existing or approved solar projects. For the zones with MW potential below 40 MW, it is assumed that interconnecting those zones via distribution system or sub-transmission system is more cost-effective, and therefore, those zones are removed from the



transmission REZ analysis. The total potential MW capacity used for study is 3,344 MW.



Figure 5-4: Adjusted Utility Scale PV MW Potential on O'ahu Island

By considering both grid-scale PV zone, as well as existing O'ahu island transmission infrastructure, groups of zones are formed, which is shown in Figure 5-5. Power flow studies for different transmission upgrade options will be performed to determine the estimated transmission infrastructure upgrade requirements for each option. The transmission upgrade options will be designed to export the full potential capacity of the REZ to the rest of the grid. The power flow simulation will assume there is enough reactive power available at vicinity of load center in order to make the power flow problem solvable.

Future analyses will be required to determine if additional reactive sources (and other grid requirements) will be needed. Additionally, there may be other solutions such as grid scale time shift battery energy storage (BESS) that may be considered in future studies as an option to reduce the requirements of transmission upgrade.





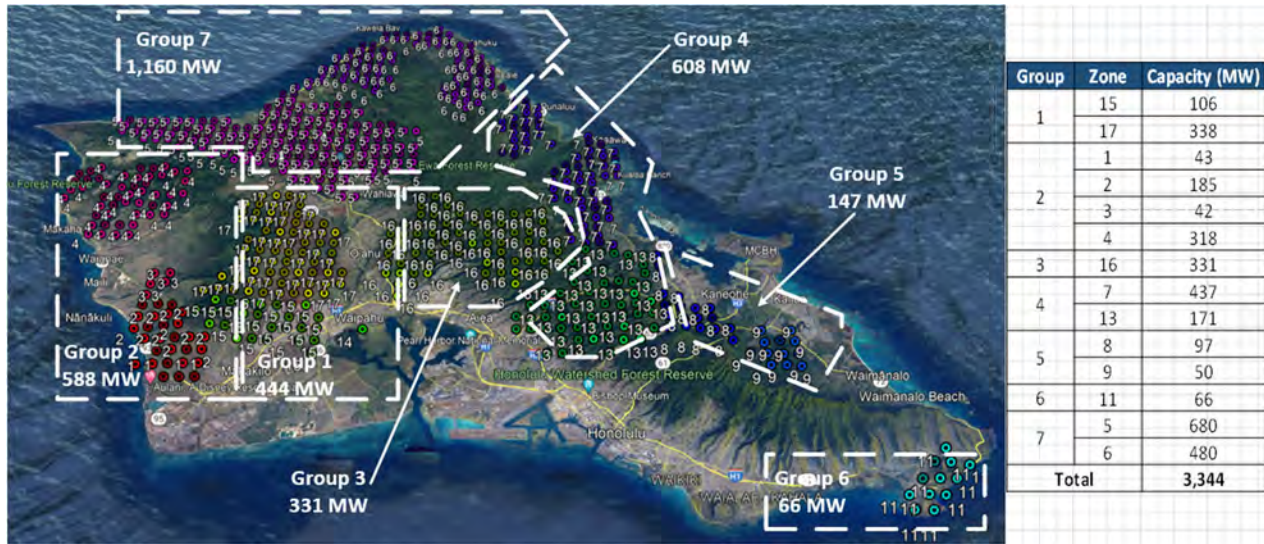

Figure 5-5: Group of REZs for O’ahu Island

For O’ahu, off-shore wind is also considered as an important renewable resource. Per the NREL off-shore wind study report, it is assumed that there is 600 MW off-shore wind potential available, and can be interconnected to the O’ahu transmission system via either the Kahe, Iwilei, or Koolau 138 kV buses. Onshore transmission needs for this interconnection will also be evaluated within this study.

*Maui Island Transmission REZ – Preliminary Update*

According to the NREL study results, Maui has 2,828 MW of grid-scale solar potential (PV-2-5, after removing the approved projects and in-study projects) and 421 MW wind potential (WIND-3-20). Compared to O’ahu, Maui’s total PV and wind potential is much higher than the forecasted 2040 peak load (284 MW). Therefore, the study does not pursue to identify the transmission infrastructure upgrade requirement to interconnect all 2,828 MW of capacity. Instead, the study will identify approximately 1,500 MW of capacity for Maui island (more than 5 times the forecasted peak load MW). It is worth noting that considering the wind potential is much smaller than the grid-scale PV potential, for the area with both PV and wind potential, the study is performed using the grid-scale PV MW potential.

The capacity of each zone was adjusted to subtract the capacity of existing or approved solar projects. The adjusted grid-scale PV potential on Maui island is shown in Figure 5-6.



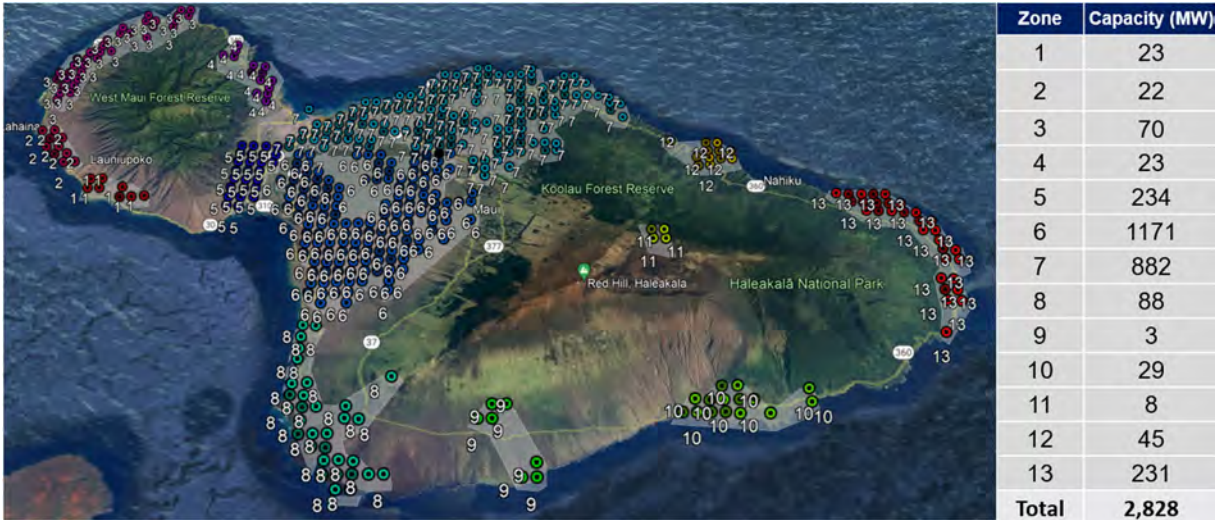

Figure 5-6: Adjusted Utility Scale PV MW Potential on Maui Island

Considering the study will only identify infrastructure requirement to interconnect 1,500 MW of potential capacity, zones were removed from consideration based on the following:

1. Zones with low MW potential (such as zone 8 and 9)
2. Zones that are far away from existing infrastructure (such as zone 8 and 10)
3. Zones near existing transmission lines with limited capacity ratings (such as zone 12 and 13)

Transmission REZ options on Maui island are shown in Figure 5-7 and Figure 5-8.





Figure 5-7: Maui Island Transmission REZ – Option 1





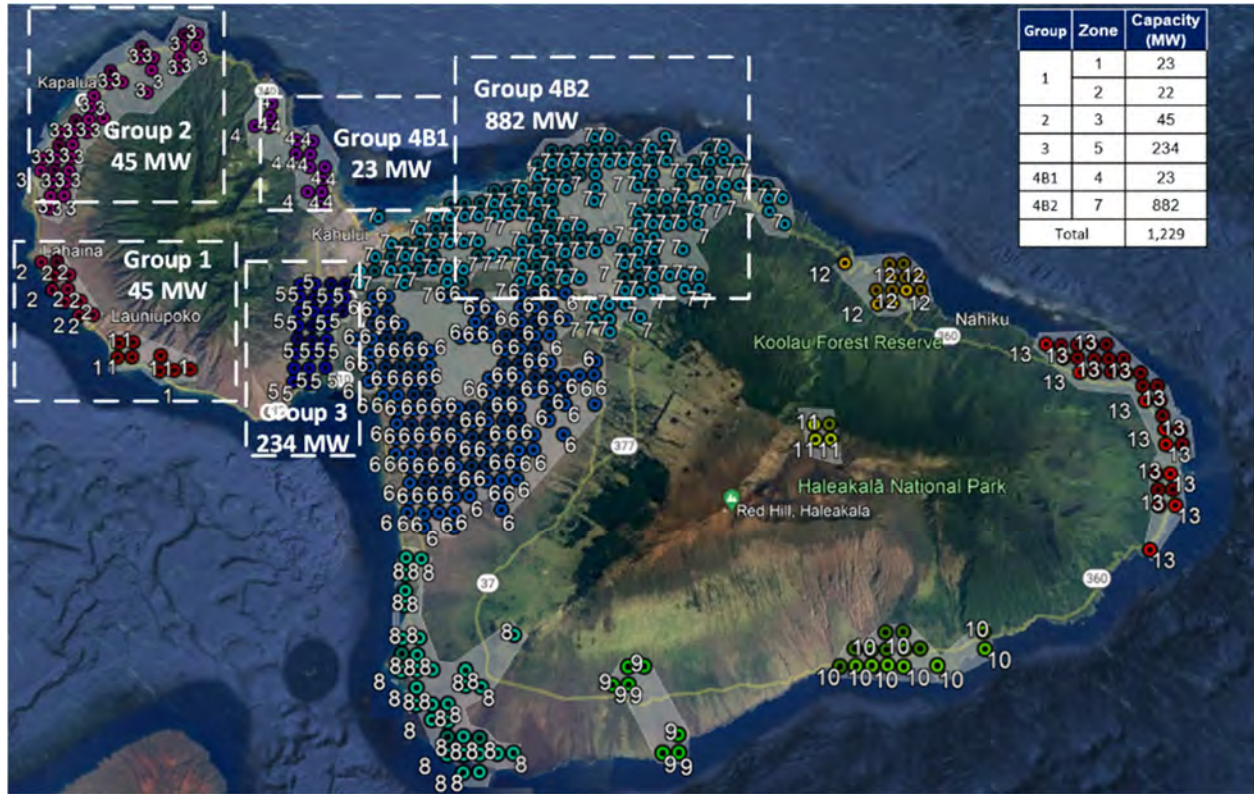

Figure 5-8: Maui Island Transmission REZ – Option 2

*Hawai'i Island Transmission REZ – Preliminary Update*

Similar to Maui island, Hawai'i island also has much larger renewable potential (around 40,000 MW) compared to the forecasted 2040 peak load (216 MW). The study will target to interconnect 1,500 MW renewable potential into the system. Also, on Hawai'i island, there is a large amount of overlap between grid-scale PV potential zones and wind potential zones, and grid-scale PV potential MW is much larger than the wind potential; therefore, the grid-scale PV MW potential will be used for the study.

The capacity of each zone was adjusted to subtract the capacity of existing or approved solar projects. The adjusted grid-scale PV MW potential on the Hawai'i island is shown in Figure 5-9.



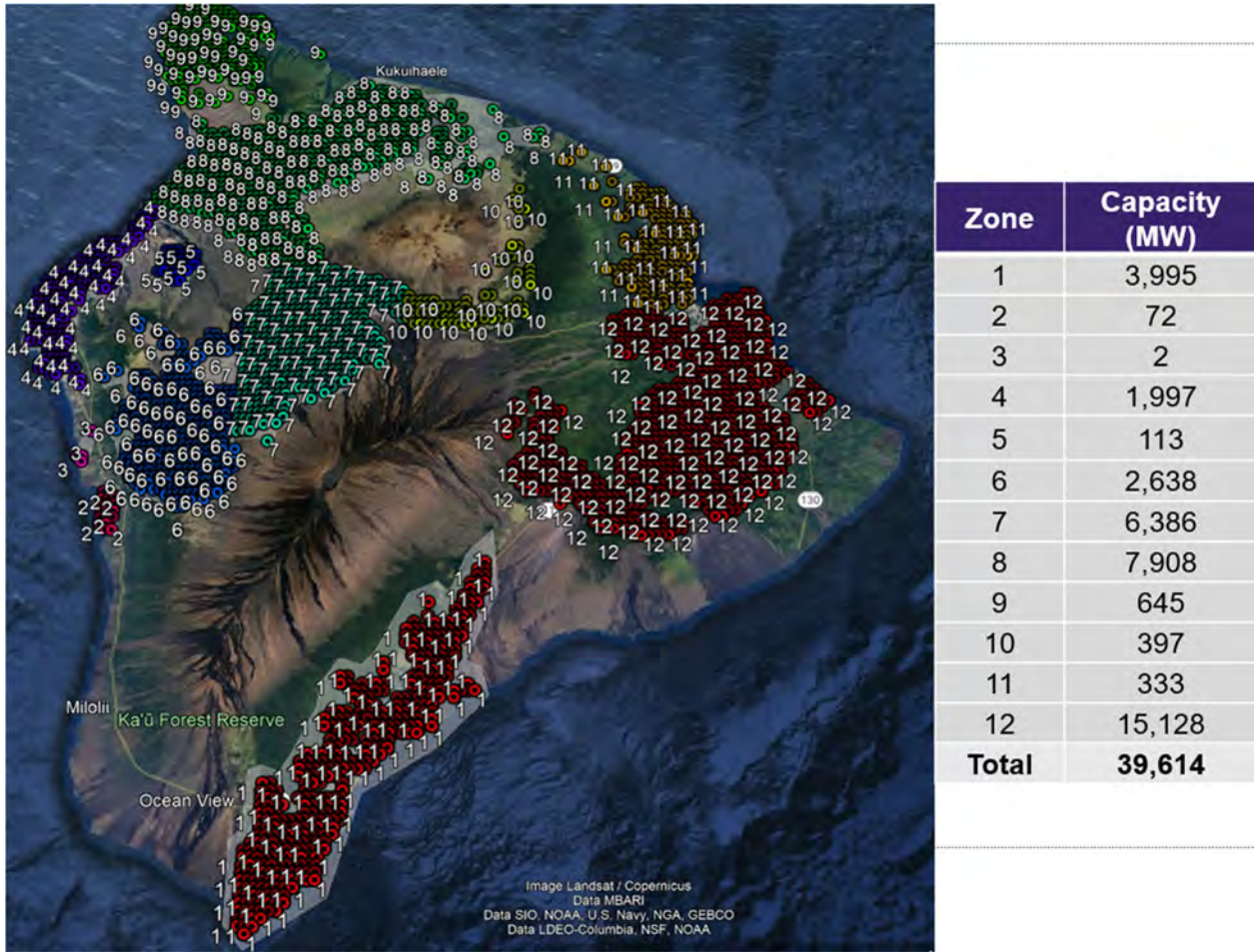

Figure 5-9: Adjusted Utility Scale PV MW Potential on Hawai'i Island

Considering the study will only identify infrastructure requirement to interconnect 1,500 MW potential, zones were removed from consideration based on the following:

1. Zones with low MW potential (such as zone 3)
2. Zones that are far away from existing infrastructure (such as zone 6 and 7)
3. Zones near existing transmission lines with limited capacity ratings (such as zone 1)

Also, balancing generation in different geographic locations of island is considered during the process of determining the transmission REZs for Hawai'i island. Two different Transmission REZ options are developed on Hawai'i island, which are shown in Figure 5-10 and Figure 5-11.





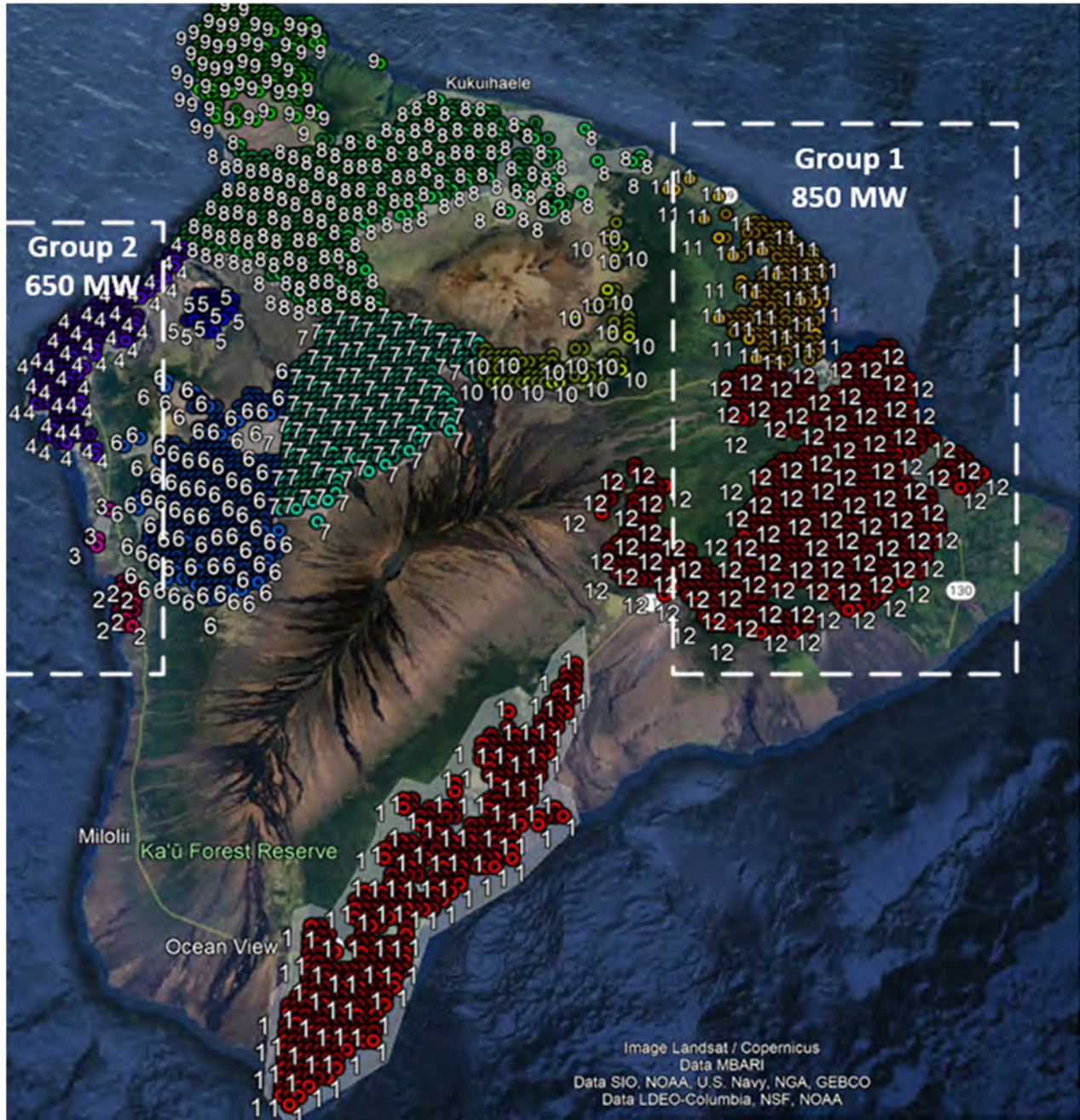

Figure 5-10: Hawai'i Island Transmission REZ – Option 1

In Option 1 (Figure 5-10), two REZs are planned on east and west side of Hawai'i island: Group 1 consists of 850 MW potential from Zone 11 and Zone 12, and Group 2 consists of 650 MW potential from Zone 2, 3 and 4.





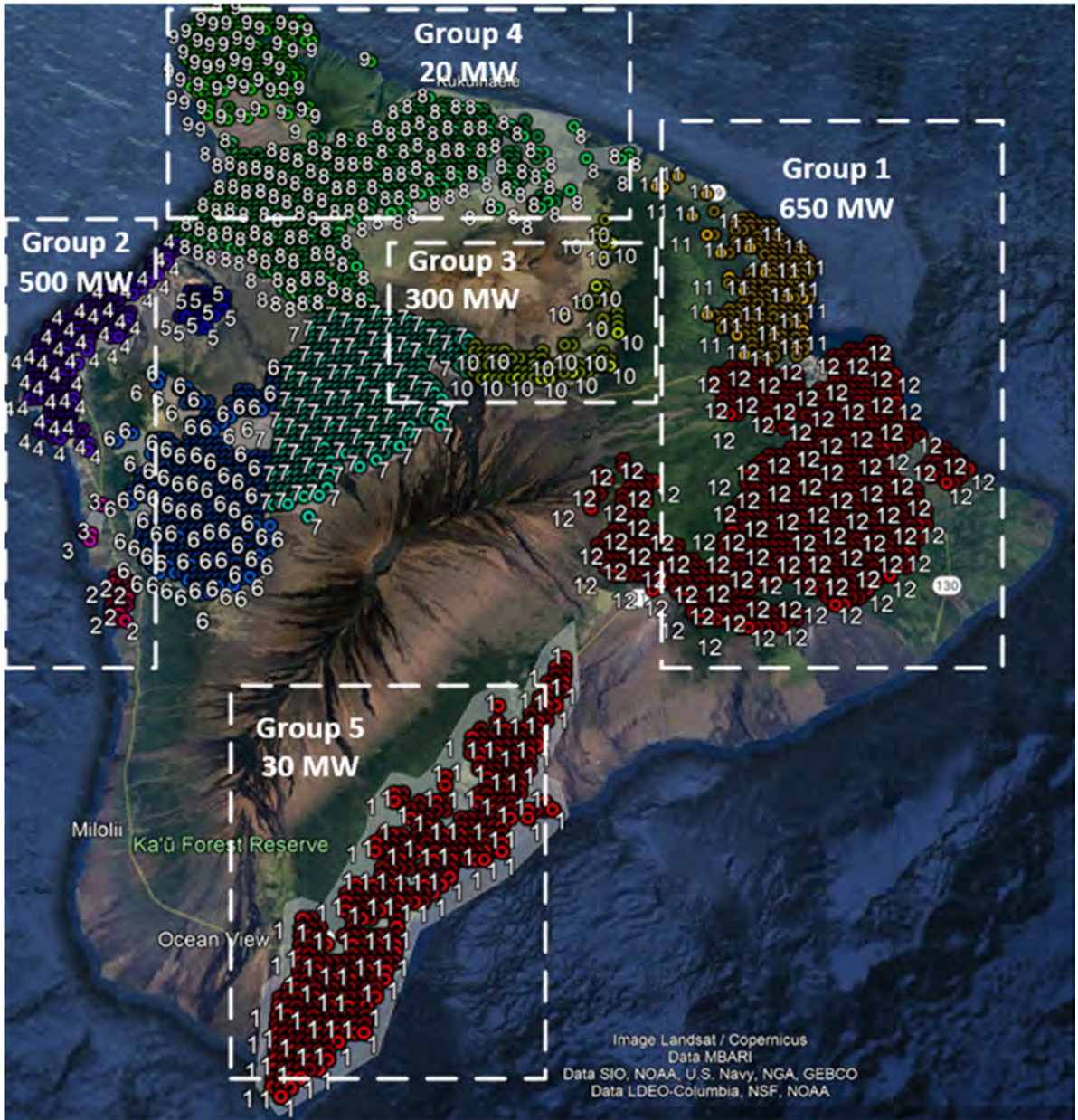

Figure 5-11: Hawai'i Island Transmission REZ – Option 2

In Option 2 (Figure 5-11), five REZs are planned on east, west, north, south side and central of Hawai'i island: Group 1 consists of 650 MW potential from Zone 11 and Zone 12, Group 2 consists of 500 MW potential from Zone 2, 3 and 4, Group 3 consists of 300 MW from Zone 7 and 10, Group 4 consists of 20 MW from Zone 8 and 9, and Group 5 has 30 MW from Zone 1.



## 6 Modeling Scenarios and Sensitivities

Scenarios and sensitivities prioritize cases that are meaningfully different than the reference portfolio. They are intended to test different customer behaviors and changes in policy, rather than specific programs or technologies. Although certain technologies will be selected in the reference portfolio in the Grid Needs Assessment, ultimately, the solution evaluation process will determine the specific resources that become part of the Hawaiian Electric's portfolio.

The scenarios and sensitivities have evolved throughout the IGP process, reflecting stakeholder feedback from the Stakeholder Council, SEOWG, and TAP. At the March 12, 2020 Stakeholder Council meeting, the Company shared the four sensitivities that it proposed, and an additional six sensitivities proposed by stakeholders. The four proposed by the Company included:

- Sensitivity #1: Value of Market DER ("DER Freeze")
  - Determine the system value of the forecasted market DER uptake by running a case where no incremental DERs are added beyond 2020 levels.
- Sensitivity #2: No Future Transmission Infrastructure
  - Determine the system value of expanding the DER uptake by limiting new transmission infrastructure and shifting the generation options to future DER resources
- Sensitivity #3: High Energy Efficiency
  - Understand the system value of increased efficiency, above what is assumed in the sales forecast
- Sensitivity #4: No State Investment Tax Credit
  - Understand the impact of no State ITC for PV on the future resource portfolio

The six sensitivities proposed by stakeholders included:

- Sensitivity #5: Non Grid-Participating Customer Storage
  - Determine the system value of existing net energy metering customers adopting storage and operating as a non-export load shift resource
- Sensitivity #6: Grid-Participating Customer Storage
  - Determine the system value of additional distributed storage that is able to charge from / export to the grid and be capable of providing grid services
- Sensitivity #7: Customer Controlled EV Charging
  - Understand the system value of customers using behind the meter storage to charge their electric vehicles
- Sensitivity #8: Grid-Participating, Managed EV Charging
  - Understand the system value of managing EV charging and moving that portion of load to other times of day
- Sensitivity #9: Offshore Wind Only
  - Understand the impact of limiting future renewable resource options to offshore wind on the future resource portfolio
- Sensitivity #10: Low Renewable Generation





- Understand the impact of low renewable generation from wind and PV resources for an extended period (1 week+)

Subsequently, the TAP's review of the inputs and assumptions led to their recommendation that the Company consider testing the sensitivity of models and resulting portfolios by running bookend scenarios that utilize the cumulative potential high and low load forecasts for each layer. To that end, the Company should also consider wider adoption forecast of customer technologies. The Company's March 2021 update to the I&A reflected the addition of bookend scenarios and changes to the customer adoption forecasts as described throughout this document. Considerable time was spent with stakeholders discussing the development and updates to the customer technology forecasts, for which stakeholders have made significant contributions in this area.

Through STWG meetings, stakeholders suggested that additional "freeze" cases should be considered, for example, EE freeze and EV freeze to approximate the value of those forecast layers compared to the load being served by other sources of generation. In response to Review Point Guidance, the Company also added a high fuel sensitivity.

This section describes the sensitivities that will be evaluated throughout the IGP process, with a clear explanation of the assumptions used for each sensitivity. In developing these revised sensitivities, the Company considered all of the stakeholder feedback received to date, while balancing where meaningful learnings can take place to help inform robust decision making.

---

## 6.1 RESOLVE MODELING SCENARIOS AND SENSITIVITIES

This section describes the process for developing scenario and sensitivity analyses in the Grid Needs Assessment. Scenario and sensitivity analyses can help inform and stress test the RESOLVE reference case to develop a more robust portfolio. Hawaiian Electric developed the following scenarios and sensitivities in collaboration with stakeholders in the STWG, Solution Evaluation and Optimization Working Group (SEOWG), Stakeholder Council, and Technical Advisory Panel.

### 6.1.1 Scenario and Sensitivity Development Process

The process for developing sensitivities and incorporating their results into the reference case is described below.

**Step 1:** Hawaiian Electric proposes sensitivities to inform the Grid Needs.

**Step 2:** Stakeholders in the SEOWG and STWG provide feedback and suggestions for each sensitivity. The SEOWG and more recently the STWG have been serving as the venue to solicit feedback and clarify the details for each of



the sensitivities.

**Step 3:** Hawaiian Electric incorporates feedback to refine each sensitivity. As part of this step, Hawaiian Electric will formulate meaningful scenarios for each of the sensitivities and develop them into modeling cases that can be analyzed in RESOLVE.

**Step 4:** The Technical Advisory Panel (TAP) provides independent review of the grid service needs assessment and sensitivities as the independent evaluator for the IGP process. Over the course its review, the TAP can recommend additional sensitivity analyses or feasibility checks as deemed prudent to facilitate its review.

**Step 5:** The Stakeholder Council and STWG reviews the grid service needs assessment and sensitivities. The Stakeholder Council and STWG members will have an advance opportunity to review and comment on the Grid Needs Assessment and sensitivity analyses prior to the review point filing.

### 6.1.2 Revised Sensitivities and Scenarios

Table 6.1 describes the original set of sensitivities proposed and the disposition of each.

Table 6.1 Original proposed sensitivities

Sensitivity Name	Disposition
1. DER Freeze	Modeled as part of the DER freeze scenarios in the DER Docket. An updated sensitivity will be run using revised forecasts and inputs and assumptions to help inform future program design.
2. No Future Transmission Infrastructure	This sensitivity will be combined with the offshore wind sensitivity, and also include lower renewable development potential estimates based on stakeholder feedback. The combination of these factors will be a new sensitivity called, Land Constrained, where development of onshore resources are limited by land constraints, including new transmission.
3. High Energy Efficiency	High energy efficiency will be incorporated as part of the bookend scenarios.
4. No State ITC for PV	No changes are being made for this sensitivity.
5. Non Grid-Participating Customer Storage	This scenario informs program design rather than resource plans. To that end, the DER Parties modeled this sensitivity as part of their "Load Shift Scenario in the DER docket. Additionally, the bookend analysis should capture any impacts this sensitivity would have on the load served by the Company.



Sensitivity Name	Disposition
6. Grid-Participating Customer Storage	See sensitivity #5 above. The Company also modeled a version of this sensitivity as part of the Company’s proposal for emergency demand response in the DER docket.
7. Customer Controlled EV Charging	The bookend analysis should capture any impacts this sensitivity would have on the load served by the Company.
8. Grid-Participating, Managed EV Charging	The bookend analysis should capture any impacts this sensitivity would have on the load served by the Company.
9. Offshore Wind Only	See sensitivity #2, above.
10. Low Renewable Generation	No changes are being made to this sensitivity.
11. Higher Customer Technology Adoption Bookend	The Company reviewed the various combinations of the updated forecast layers. As shown in Figure XX, the high and low customer adoption does not offer a significantly different demand than the base case. Therefore, the Company will run a high and low load case, as shown in Figure XX, instead of high and low customer adoption cases.
12. Lower Customer Technology Adoption Bookend	See sensitivity #11, above
13. High Load	The Company will proceed with a high load sensitivity based on the combination of forecast layers that result in the highest demand served by the Company.

Based on stakeholder discussions and to meet the intent and objective of sensitivities, the revised sensitivities are provided in Table 6.2.

Table 6.2: Table of Proposed Sensitivities

Sensitivity Name	Purpose
1. High Load Customer Technology Adoption Bookend	Understand the impact of customer adoption of technologies for DER, electric vehicles, energy efficiency, and time-of-use rates that lead to higher loads.
2. Low Load Customer Technology Adoption Bookend	Understand the impact of customer adoption of technologies for DER, electric vehicles, energy efficiency, and time-of-use rates that leads to lower loads.
3. DER Freeze	Understand the value of the distributed PV and BESS uptake in the Base forecast. Informative for program design and solution sourcing.



Sensitivity Name	Purpose
4. EV Freeze	Understand the value of the electric vehicles uptake in the Base forecast. Informative for program design and solution sourcing.
5. EE Freeze	Understand the value of the energy efficiency uptake in the Base forecast. Informative for program design and solution sourcing.
6. Land Constrained	Understand the impact of limited availability of land for future solar, onshore wind, and biomass development.
7. No State ITC for PV	Understand the impact of removing the state ITC for PV.
8. Low Renewable Generation	Understand the value of the resource portfolio during periods of low renewable production and additional forced outage combinations.
9. High Fuel Price	Understand the impact of higher fuel prices on the resource plan.

Table 6.3 provides a high level mapping of the various forecast layers being used for each of the scenario and sensitivity analyses.

Table 6.3: Forecast Layer Mapping of Modeling Scenarios and Sensitivities

No	Modeling Case	DER Forecast	EV Forecast	EE Forecast	TOU Load Shape	Fuel Price Forecast	Resource Cost Forecast	Resource Potential
1	Base	Base Forecast	Base Forecast	Base Forecast	Managed EV Charging	Base Forecast	Base Forecast	NREL Alt-1
2	High Load Customer Technology Adoption Bookend	Low Forecast	High Forecast	Low Forecast	Unmanaged EV Charging	Base Forecast	Base Forecast	NREL Alt-1
3	Low Load Customer Technology Adoption Bookend	High Forecast	Low Forecast	High Forecast	Managed EV Charging	Base Forecast	Base Forecast	NREL Alt-1
4	DER Freeze	DER Freeze	Base Forecast	Base Forecast	Managed EV Charging	Base Forecast	Base Forecast	NREL Alt-1
5	EV Freeze	Base Forecast	EV Freeze	Base Forecast	Managed EV Charging	Base Forecast	Base Forecast	NREL Alt-1



No	Modeling Case	DER Forecast	EV Forecast	EE Forecast	TOU Load Shape	Fuel Price Forecast	Resource Cost Forecast	Resource Potential
6	EE Freeze	Base Forecast	Base Forecast	EE Freeze	Managed EV Charging	Base Forecast	Base Forecast	NREL Alt-1
7	Land Constrained	Base Forecast	Base Forecast	Base Forecast	Managed EV Charging	Base Forecast	Base Forecast	Land Constrained Resource Potential
8	No State ITC for PV	No State ITC Forecast	Base Forecast	Base Forecast	Managed EV Charging	Base Forecast	No State ITC applied to PV resources	NREL Alt-1
9	Low Renewable Generation	Base Forecast	Base Forecast	Base Forecast	Managed EV Charging	Base Forecast	Base Forecast	NREL Alt-1
10	High Fuel Price	Base Forecast	Base Forecast	Base Forecast	Managed EV Charging	EIA High Fuel Price Forecast	Base Forecast	NREL Alt-1

*Sensitivity #2, #3: Bookends for Customer Technology Adoption*

Bookends will be evaluated as a scenario around the reference forecast, to establish a plausible set of assumptions for each of the layers within the load forecast that define a cumulative high forecast and cumulative low load forecast for customer technology adoption. These high and low bookends include the evaluation of higher and lower adoption of distributed energy resources, electric vehicles, energy efficiency, and time-of-use (“TOU”) rates that are purposefully combined to create proper high and low load bookends, which all combinations of the load layers would reside within. While the base forecast provided in the inputs workbooks represent the best estimate of those assumptions, the results of the bookends will be useful to directionally inform how the resource plan and system costs will change as load increases or decreases.

*Sensitivity #4: DER Freeze*

The purpose of this sensitivity is to determine the value of the base case DER uptake that is already assumed in the reference portfolio by evaluating a case where no incremental DER is added beyond 2020 levels. RESOLVE will be allowed to build grid-scale resources to meet future RPS and grid needs. Compared to the reference case, this will provide the value of the base DER forecast and a lower bound on the value of DER in the portfolio. This sensitivity can be used to determine the appropriate mechanism for solution sourcing and program design.



#### *Sensitivity #5: EV Freeze*

The purpose of this sensitivity is to determine the value of the base case EV uptake that is already assumed in the reference portfolio by evaluating a case where no incremental EV is added beyond 2021 levels. RESOLVE will be allowed to build grid-scale resources to meet future RPS and grid needs. Compared to the reference case, this will provide the value of the base EV forecast and a lower bound on the value of EV in the portfolio. This sensitivity can be used to determine the appropriate mechanism for solution sourcing and program design.

#### *Sensitivity #6: EE Freeze*

The purpose of this sensitivity is to determine the value of the base case EE uptake that is already assumed in the reference portfolio by evaluating a case where no incremental EE is added beyond 2021 levels. RESOLVE will be allowed to build grid-scale resources to meet future RPS and grid needs. Compared to the reference case, this will provide the value of the base EE forecast and a lower bound on the value of EE in the portfolio. This sensitivity can be used to determine the appropriate mechanism for solution sourcing and program design.

#### *Sensitivity #7: Land Constrained*

The purpose of this sensitivity is to understand the impact of limited land availability to develop future solar, onshore wind, and biomass resources. Biomass will be removed as a resource option in RESOLVE and the land availability for development of wind, solar and new transmission lines will be limited based on stakeholder feedback. This sensitivity will use a lessor resource potential than the PV-Alt-1 case from the NREL resource potential study. RPS and grid needs will be met by developing offshore resources or additional DER above the base forecast through a DER aggregator.

#### *Sensitivity #8: No State ITC for PV*

The purpose of this sensitivity is to understand the impact of not having the State investment tax credit as part of the resource cost assumption for PV. This sensitivity will compare the resulting resource plan without state tax credits for PV against the reference case.

#### *Sensitivity #9: Low Renewable Generation*

The purpose of this sensitivity is to understand how periods of low energy production from wind and PV resources impact the resilience and reliability of the resource portfolio. Low PV and wind generation as well as increased forced outages of thermal generation will be examined as a stress test of the base case portfolio. Low PV and wind profiles will be defined using historical production as well as production profiles developed through NREL's System Advisory Model and data provided in NREL's National Solar Radiation Database.



*Sensitivity #10: High Fuel Price*

The purpose of this sensitivity is to understand the impact of a higher fuel forecast on the resource portfolio. RESOLVE will be allowed to optimize the retirement of the thermal generating units compared to the base case where a fixed removal from service schedule is assumed.



## 7 Thermal Generating Unit Portfolios

Hawaiian Electric’s thermal generating unit capacity is provided by a mix of utility-owned generation and independent power producers (IPPs). Key inputs to characterize the operation of the utility-owned generation include the minimum and maximum capacity, heat rate coefficients, planned maintenance outages, forced outage rates, and maintenance outage rates.

### Minimum and Maximum Capacity

The minimum and maximum capacity of a generating unit define its dispatchable range.

### Heat Rate Coefficients

The heat rate coefficients define the heat input function  $y = cx^2 + bx + a$  where  $y$  is the amount of fuel consumed to produce at the megawatt level  $x$  for one hour.

### Maintenance Outages

Maintenance outages can be defined as discrete occurrences with a start date and duration or can be defined as a percentage of the year that the unit will be out of service on maintenance. Maintenance outages can remove an entire unit from service or reduce the generating unit’s capacity that is available for service.

### Forced Outages

Forced outages are unexpected and unplanned generating unit outages and are defined as a percentage of the year that the unit may experience an outage based on historical data.

## *O’ahu*

Table 7.1: O’ahu Minimum and Maximum Capacity for Thermal Resources

Unit	Operating Minimum (Net MW)	Normal Top Load (Net MW)	Fuel Type
Kahe 1	23.2	82.6	LSFO
Kahe 2	23.3	82.4	LSFO
Kahe 3	23.1	86.1	LSFO
Kahe 4	23.1	85.4	LSFO
Kahe 5	50.4	134.9	LSFO
Kahe 6	50.4	134.7	LSFO
Waiau 3	23.5	47.1	LSFO
Waiau 4	23.5	46.5	LSFO
Waiau 5	23.4	54.4	LSFO
Waiau 6	23.5	53.7	LSFO





Unit	Operating Minimum (Net MW)	Normal Top Load (Net MW)	Fuel Type
Waiau 7	23.1	82.9	LSFO
Waiau 9	5.9	52.9	Diesel
Campbell Industrial Park	41.2	129.0	Diesel
H-Power			
AES	63.0	180.0	Coal
Airport DSG	4.0	8.0	Biodiesel
Schofield 2	4.0	8.1	ULSD / Biodiesel
Schofield 3	4.0	8.1	
Schofield 4	4.0	8.1	ULSD / Biodiesel
Schofield 5	4.0	8.1	ULSD / Biodiesel
Schofield 6	4.0	8.1	ULSD / Biodiesel

Unit	A Coefficient (MMBTU/hr)	B Coefficient (MMBTU/hr-MW)	C Coefficient (MMBTU/hr-MW^2)
Kahe 1	72.1042	9.1921	0.0022
Kahe 2	72.0121	8.3600	0.0118
Kahe 3	73.2636	8.1711	0.0167
Kahe 4	116.5162	6.5015	0.0264
Kahe 5	113.3406	7.9454	0.0106
Kahe 6	59.8050	9.4934	0.0031
Waiau 3	60.8508	8.5429	0.0309
Waiau 4	25.8219	10.3352	0.0272
Waiau 5	37.8539	10.2088	0.0019
Waiau 6	33.4800	10.0324	0.0143
Waiau 7	101.1916	7.4411	0.0174
Waiau 8	78.0588	8.2162	0.0117
Waiau 9	206.3054	7.0804	0.0249
Waiau 10	190.6694	8.0059	0.0184
Campbell Industrial Park	271.1301	8.6971	0.0050
H-Power	1	1	1
AES	258.7479	14.9713	0.0051



Unit	A Coefficient (MMBTU/hr)	B Coefficient (MMBTU/hr-MW)	C Coefficient (MMBTU/hr-MW <sup>2</sup> )
Kalaeloa Energy Partners	299.0258	4.4067	0.0093
Airport DSG	0.0000	10.2090	0.0000
Schofield 1	8.5503	6.8097	
Schofield 2	8.4677	6.7967	0.0614
Schofield 3	8.5584	6.7376	
Schofield 4	8.5071	6.6227	0.0814
Schofield 5	8.4171	6.8237	0.0550
Schofield 6	7.6438	7.0152	0.0513

Table 7.3: O’ahu Forced Outage Rates for Thermal Resources (1 of 4)

Year	Waiau 3	Waiau 4	Waiau 5	Waiau 6	Waiau 7	Waiau 8	Waiau 9	Waiau 10
%								
2021	7	7	4.5	4.5	4.5	4.5	4	4
2022	7	7	4.5	4.5	4.5	4.5	4	4
2023	7	7	4.5	4.5	4.5	4.5	4	4
2024	7	7	4.5	4.5	4.5	4.5	4	4
2025	9	9	5	5	4.5	4.5	4	4
2026	9	9	5	5	4.5	4.5	4	4
2027	9	9	5	5	4.5	4.5	4	4
2028	9	9	5	5	4.5	4.5	4	4
2029	9	9	5	5	4.5	4.5	4	4
2030	9	9	6	6	5.5	5.5	4	4
2031	9	9	6	6	5.5	5.5	4	4
2032	9	9	6	6	5.5	5.5	4	4
2033	9	9	6	6	5.5	5.5	4	4
2034	9	9	6	6	5.5	5.5	4	4
2035	9	9	6	6	5.5	5.5	4	4
2036	9	9	6	6	5.5	5.5	4	4
2037	9	9	6	6	5.5	5.5	4	4
2038	9	9	6	6	5.5	5.5	4	4
2039	9	9	6	6	5.5	5.5	4	4
2040	9	9	6	6	5.5	5.5	4	4
2041	9	9	6	6	5.5	5.5	4	4
2042	9	9	6	6	5.5	5.5	4	4
2043	9	9	6	6	5.5	5.5	4	4



Integrated Grid Planning Inputs and Assumptions | August 2021 Update

2044	9	9	6	6	5.5	5.5	4	4
2046	9	9	6	6	5.5	5.5	4	4
2048	9	9	6	6	5.5	5.5	4	4
2050	9	9	6	6	5.5	5.5	4	4

Year	Kahe 1	Kahe 2	Kahe 3	Kahe 4	Kahe 5	Kahe 6	CIP CT-1
%							
2021	4.5	4.5	4.5	4.5	5	5	3
2022	4.5	4.5	4.5	4.5	5	5	3
2023	4.5	4.5	4.5	4.5	5	5	3
2024	4.5	4.5	4.5	4.5	5	5	3
2025	4.5	4.5	4.5	4.5	5	5	3
2026	4.5	4.5	4.5	4.5	5	5	3
2027	4.5	4.5	4.5	4.5	5	5	3
2028	4.5	4.5	4.5	4.5	5	5	3
2029	4.5	4.5	4.5	4.5	5	5	3
2030	5.5	5.5	5	5	5	5	3
2031	5.5	5.5	5	5	5	5	3
2032	5.5	5.5	5	5	5	5	3
2033	5.5	5.5	5	5	5	5	3
2034	5.5	5.5	5	5	5	5	3
2035	5.5	5.5	5	5	5	5	3
2036	5.5	5.5	5	5	5	5	3
2037	5.5	5.5	5	5	5	5	3
2038	5.5	5.5	5	5	5	5	3
2039	5.5	5.5	5	5	5	5	3
2040	5.5	5.5	5	5	5	5	3
2041	5.5	5.5	5	5	5	5	3
2042	5.5	5.5	5	5	5	5	3
2043	5.5	5.5	5	5	5	5	3
2044	5.5	5.5	5	5	5	5	3
2045	5.5	5.5	5	5	5	5	3



Integrated Grid Planning Inputs and Assumptions | August 2021 Update

2046	5.5	5.5	5	5	5	5	3
2047	5.5	5.5	5	5	5	5	
2048	5.5	5.5	5	5	5	5	3
2049	5.5	5.5	5	5	5	5	3
2050	5.5	5.5	5	5	5	5	3

Year	Airport DSG	Schofield 1	Schofield 2	Schofield 3	Schofield 4	Schofield 5	Schofield 6
2021	5	2	2	2	2	2	2
2022	5	2	2	2	2	2	2
2023	5	2	2	2	2	2	2
2024	5	2	2	2	2	2	2
2025	5	2	2	2	2	2	2
2026	5	2	2	2	2	2	2
2027	5	2	2	2	2	2	2
2028	5	2	2	2	2	2	2
2029	5	2	2	2	2	2	2
2030	5	2	2	2	2	2	2
2031	5	2	2	2	2	2	2
2032	5	2	2	2	2	2	2
2033	5	2	2	2	2	2	2
2034	5	2	2	2	2	2	2
2035	5	2	2	2	2	2	2
2036	5	2	2	2	2	2	2
2037	5	2	2	2	2	2	2
2038	5	2	2	2	2	2	2
2039	5	2	2	2	2	2	2
2040	5	2	2	2	2	2	2
2041	5	2	2	2	2	2	2
2042	5	2	2	2	2	2	2
2043	5	2	2	2	2	2	2
2044	5	2	2	2	2	2	2
2045	5	2	2	2	2	2	2
2046	5	2	2	2	2	2	2
2047	5	2	2	2	2	2	2



2048	5	2	2	2	2	2	2
2050	5	2	2	2	2	2	2

Table 7.6: O’ahu Forced Outage Rates for Thermal Resources (4 of 4)

Year	H-POWER	Kalaeloa	AES
%			
2021	3	1.5	1.5
2022	3	1.5	1.5
2023	3	1.5	
2024	3	1.5	
2025	3	1.5	
2026	3	1.5	
2027	3	1.5	
2028	3	1.5	
2029	3	1.5	
2030	3	1.5	
2031	3	1.5	
2032	3	1.5	
2033	3	1.5	
2034	3	1.5	
2035	3	1.5	
2036	3	1.5	
2037	3	1.5	
2038	3	1.5	
2039	3	1.5	
2040	3	1.5	
2041	3	1.5	
2042	3	1.5	
2043	3	1.5	
2044	3	1.5	
2045	3	1.5	
2046	3	1.5	
2047	3	1.5	
2048	3	1.5	
2049	3	1.5	



Year	H-POWER	Kalaeloa	AES
%			
2050	3	1.5	

Table 7.7: O’ahu Maintenance Outage Rates for Thermal Resources (1 of 3)

Year	Waiau 3	Waiau 4	Waiau 5	Waiau 6	Waiau 7	Waiau 8	Waiau 9	Waiau 10
%								
2021	1.92	1.92	5.75	5.75	7.67	7.67	3.84	15.34
2022	13.42	1.92	21.10	13.42	3.84	3.84	3.84	3.84
2023	1.92	13.42	3.84	3.84	13.42	13.42	3.84	3.84
2024	3.84	3.84	5.75	5.75	7.67	7.67	3.84	3.84
2025	13.42	1.92	13.42	13.42	1.92	1.92	3.84	3.84
2026	0.00	13.42	0.00	0.00	17.26	13.42	26.85	3.84
2027	3.84	3.84	5.75	5.75	5.75	5.75	3.84	26.85
2028	13.42	1.92	13.42	21.10	3.84	3.84	3.84	3.84
2029	1.92	13.42	1.92	1.92	13.42	21.10	3.84	3.84
2030	1.92	1.92	3.84	3.84	5.75	5.75	3.84	3.84
2031	13.42	1.92	21.10	13.42	1.92	1.92	3.84	3.84
2032	1.92	13.42	1.92	1.92	13.42	13.42	15.34	3.84
2033	1.92	1.92	5.75	5.75	5.75	5.75	3.84	15.34
2034	13.42	1.92	13.42	13.42	5.75	5.75	3.84	3.84
2035	0.00	13.42	0.00	0.00	17.26	13.42	3.84	3.84
2036	1.92	1.92	5.75	5.75	5.75	5.75	3.84	3.84
2037	13.42	0.00	13.42	21.10	1.92	1.92	3.84	3.84
2038	0.00	13.42	1.92	1.92	13.42	21.10	26.85	3.84
2039	1.92	1.92	5.75	5.75	3.84	3.84	3.84	26.85
2040	13.42	1.92	13.42	13.42	3.84	3.84	3.84	3.84
2041	1.92	13.42	5.75	5.75	13.42	13.42	3.84	3.84
2042	1.92	1.92	5.75	5.75	5.75	5.75	5.75	5.75
2043	1.92	1.92	5.75	5.75	5.75	5.75	5.75	5.75
2044	1.92	1.92	5.75	5.75	5.75	5.75	5.75	5.75
2045	1.92	1.92	5.75	5.75	5.75	5.75	5.75	5.75
2046	1.92	1.92	5.75	5.75	5.75	5.75	5.75	5.75
2047	1.92	1.92	5.75	5.75	5.75	5.75	5.75	5.75
2048	1.92	1.92	5.75	5.75	5.75	5.75	5.75	5.75
2049	1.92	1.92	5.75	5.75	5.75	5.75	5.75	5.75



Year	Waiau 3	Waiau 4	Waiau 5	Waiau 6	Waiau 7	Waiau 8	Waiau 9	Waiau 10
%								
2050	1.92	1.92	5.75	5.75	5.75	5.75	5.75	5.75

Table 7.8: O’ahu Maintenance Outage Rates for Thermal Resources (2 of 3)

Year	Kahe 1	Kahe 2	Kahe 3	Kahe 4	Kahe 5	Kahe 6	CIP CT-1
%							
2021	21.10	5.75	5.75	5.75	5.75	5.75	3.84
2022	3.84	17.26	3.84	13.42	13.42	3.84	3.84
2023	3.84	5.75	13.42	5.75	3.84	13.42	3.84
2024	13.42	7.67	7.67	7.67	5.75	5.75	15.34
2025	1.92	13.42	3.84	13.42	19.18	1.92	3.84
2026	0.00	0.00	17.26	0.00	0.00	23.01	3.84
2027	13.42	7.67	7.67	7.67	5.75	5.75	3.84
2028	1.92	13.42	1.92	21.10	13.42	3.84	3.84
2029	3.84	3.84	13.42	3.84	1.92	13.42	3.84
2030	21.10	5.75	5.75	5.75	5.75	5.75	19.18
2031	3.84	17.26	1.92	13.42	13.42	1.92	3.84
2032	3.84	3.84	21.10	3.84	3.84	13.42	3.84
2033	13.42	7.67	7.67	7.67	7.67	7.67	3.84
2034	5.75	13.42	5.75	13.42	13.42	3.84	3.84
2035	0.00	0.00	13.42	1.92	1.92	23.01	3.84
2036	13.42	7.67	7.67	7.67	7.67	5.75	15.34
2037	1.92	13.42	1.92	21.10	13.42	1.92	3.84
2038	3.84	3.84	13.42	1.92	1.92	13.42	3.84
2039	21.10	5.75	5.75	5.75	5.75	5.75	3.84
2040	5.75	17.26	5.75	13.42	13.42	3.84	3.84
2041	3.84	3.84	13.42	3.84	3.84	13.42	3.84
2042	7.67	7.67	7.67	7.67	7.67	7.67	5.75
2043	7.67	7.67	7.67	7.67	7.67	7.67	5.75
2044	7.67	7.67	7.67	7.67	7.67	7.67	5.75
2045	7.67	7.67	7.67	7.67	7.67	7.67	5.75
2046	7.67	7.67	7.67	7.67	7.67	7.67	5.75
2047	7.67	7.67	7.67	7.67	7.67	7.67	5.75
2048	7.67	7.67	7.67	7.67	7.67	7.67	5.75
2049	7.67	7.67	7.67	7.67	7.67	7.67	5.75



Year	Kahe 1	Kahe 2	Kahe 3	Kahe 4	Kahe 5	Kahe 6	CIP CT-1
%							
2050	7.67	7.67	7.67	7.67	7.67	7.67	5.75

Table 7.9: O’ahu Maintenance Outage Rates for Thermal Resources (3 of 3)

Year	Airport DSG	Schofield 1	Schofield 2	Schofield 3	Schofield 4	Schofield 5	Schofield 6
%							
2021	1.92	1.90	1.90	1.90	1.90	1.90	1.90
2022	1.92	1.90	1.90	1.90	1.90	1.90	1.90
2023	1.92	1.90	1.90	1.90	1.90	1.90	1.90
2024	1.92	1.90	1.90	1.90	1.90	1.90	1.90
2025	1.92	1.90	1.90	1.90	1.90	1.90	1.90
2026	1.92	1.90	1.90	1.90	1.90	1.90	1.90
2027	1.92	1.90	1.90	1.90	1.90	1.90	1.90
2028	1.92	1.90	1.90	1.90	1.90	1.90	1.90
2029	1.92	1.90	1.90	1.90	1.90	1.90	1.90
2030	1.92	1.90	1.90	1.90	1.90	1.90	1.90
2031	1.92	1.90	1.90	1.90	1.90	1.90	1.90
2032	1.92	1.90	1.90	1.90	1.90	1.90	1.90
2033	1.92	1.90	1.90	1.90	1.90	1.90	1.90
2034	1.92	1.90	1.90	1.90	1.90	1.90	1.90
2035	1.92	1.90	1.90	1.90	1.90	1.90	1.90
2036	1.92	1.90	1.90	1.90	1.90	1.90	1.90
2037	1.92	1.90	1.90	1.90	1.90	1.90	1.90
2038	1.92	1.90	1.90	1.90	1.90	1.90	1.90
2039	1.92	1.90	1.90	1.90	1.90	1.90	1.90
2040	1.92	1.90	1.90	1.90	1.90	1.90	1.90
2041	1.92	1.90	1.90	1.90	1.90	1.90	1.90
2042	1.92	1.90	1.90	1.90	1.90	1.90	1.90
2043	1.92	1.90	1.90	1.90	1.90	1.90	1.90
2044	1.92	1.90	1.90	1.90	1.90	1.90	1.90
2045	1.92	1.90	1.90	1.90	1.90	1.90	1.90
2046	1.92	1.90	1.90	1.90	1.90	1.90	1.90
2047	1.92	1.90	1.90	1.90	1.90	1.90	1.90
2048	1.92	1.90	1.90	1.90	1.90	1.90	1.90
2049	1.92	1.90	1.90	1.90	1.90	1.90	1.90





2050 1.92 1.90 1.90 1.90 1.90 1.90 1.90

*Hawai'i Island*

Table 7.10: Hawai'i Island Minimum and Maximum Capacity for Thermal Resources

Unit	Operating Minimum (Net MW)	Normal Top Load (Net MW)	Fuel Type
PGV (2024)	20	46	Geothermal
PGV (2021, off-peak)	22.0	38.0	Geothermal
PGV (2021, on-peak)	33.9	38.0	Geothermal
Hill 5	4.0	14.2	IFO
Hill 6	8.0	20.2	IFO
Kanoelehua CT1	0.5	10.5	Diesel
Kanoelehua D11	2.0	2.0	ULSD
Kanoelehua D15	0.8	2.5	ULSD
Kanoelehua D16	0.8	2.5	ULSD
Kanoelehua D17	0.8	2.5	ULSD
Kapua D27	1.3	1.3	ULSD
Keahole CT2	5.0	13.8	Diesel
Keahole D21	0.8	2.5	ULSD
Keahole D22	0.8	2.5	ULSD
Keahole D23	0.8	2.5	ULSD
Ouli D25	1.3	1.3	ULSD
Panaewa D24	1.3	1.3	ULSD
Puna	6.0	15.7	IFO
Puna CT3	7.0	20.0	Diesel
Punaluu D26	1.3	1.3	ULSD
Waimea D12	0.8	2.5	ULSD
Waimea D13	0.8	2.5	ULSD
Waimea D14	0.8	2.5	ULSD
Keahole CT4	7.0	20.0	Diesel
Keahole CT5	7.0	20.0	Diesel
Keahole ST7	1.5	13.5	-
HEP CT1	5.0	20.8	Naphtha
HEP CT2	5.0	20.8	Naphtha
HEP ST	3.3	19.0	-



Unit	A Coefficient (MMBTU/hr)	B Coefficient (MMBTU/hr-MW)	C Coefficient (MMBTU/hr-MW <sup>2</sup> )
Hill 5	24.6229	8699.0000	0.2033
Kanoelehua CT1	74.0422	9150.1300	0.1272
Kanoelehua D15	7.6830	4326.1600	1.2637
Kanoelehua D17	7.6830	4326.1800	1.2637
Keahole CT2	56.9838	8864.6600	0.0040
Keahole D22	7.6834	4326.1400	1.2637
Ouli D25	2.8000	3200.0400	3.2800
Puna	41.8152	7738.1000	0.2001
Punaluu D26	2.8000	3200.0200	3.2800
Waimea D13	7.6830	4326.1700	1.2637
Keahole CT4	49.3842	7680.7600	0.0310
Keahole ST7	59.8609	20348.8000	0.0000
HEP CT2	56.5930	7544.0000	0.0504

Table 7.12: Hawai'i Island Forced Outage Rates for Thermal Resources (1 of 4)

Year	Hill 5	Hill 6	Puna Steam	Kanoelehua D11	Waimea D12	Waimea D13	Waimea D14	Kanoelehua D15
%								
2021	1.78	1.38	1.58	17.31	19.44	12.04	14.85	0.50
2022	1.78	1.38	1.58	17.31	19.44	12.04	14.85	0.50
2023	1.78	1.38	1.58	17.31	19.44	12.04	14.85	0.50



Integrated Grid Planning Inputs and Assumptions | August 2021 Update

<b>2024</b>	1.78	1.38	1.58	17.31	19.44	12.04	14.85	0.50
<b>2026</b>	1.78	1.38	1.58	17.31	19.44	12.04	14.85	0.50
<b>2028</b>	1.78	1.38	1.58	17.31	19.44	12.04	14.85	0.50
<b>2030</b>	1.78	1.38	1.58	17.31	19.44	12.04	14.85	0.50
<b>2032</b>	1.78	1.38	1.58	17.31	19.44	12.04	14.85	0.50
<b>2034</b>	1.78	1.38	1.58	17.31	19.44	12.04	14.85	0.50
<b>2036</b>	1.78	1.38	1.58	17.31	19.44	12.04	14.85	0.50
<b>2038</b>	1.78	1.38	1.58	17.31	19.44	12.04	14.85	0.50
<b>2040</b>	1.78	1.38	1.58	17.31	19.44	12.04	14.85	0.50
<b>2042</b>	1.78	1.38	1.58	17.31	19.44	12.04	14.85	0.50
<b>2044</b>	1.78	1.38	1.58	17.31	19.44	12.04	14.85	0.50
<b>2046</b>	1.78	1.38	1.58	17.31	19.44	12.04	14.85	0.50
<b>2048</b>	1.78	1.38	1.58	17.31	19.44	12.04	14.85	0.50
<b>2050</b>	1.78	1.38	1.58	17.31	19.44	12.04	14.85	0.50

Table 7.13: Hawai'i Island Forced Outage Rates for Thermal Resources (2 of 4)

Year	Kanoelehua D16	Kanoelehua D17	Keahole D21	Keahole D22	Keahole D23	Panaewa D24	Ouli D25	Punaluu D26
<b>2021</b>	17.65	7.09	6.73	8.33	7.99	4.14	1.65	6.40
<b>2022</b>	17.65	7.09	6.73	8.33	7.99	4.14	1.65	6.40
<b>2023</b>	17.65	7.09	6.73	8.33	7.99	4.14	1.65	6.40
<b>2024</b>	17.65	7.09	6.73	8.33	7.99	4.14	1.65	6.40
<b>2025</b>	17.65	7.09	6.73	8.33	7.99	4.14	1.65	6.40



2026	17.65	7.09	6.73	8.33	7.99	4.14	1.65	6.40
2028	17.65	7.09	6.73	8.33	7.99	4.14	1.65	6.40
2030	17.65	7.09	6.73	8.33	7.99	4.14	1.65	6.40
2032	17.65	7.09	6.73	8.33	7.99	4.14	1.65	6.40
2034	17.65	7.09	6.73	8.33	7.99	4.14	1.65	6.40
2036	17.65	7.09	6.73	8.33	7.99	4.14	1.65	6.40
2038	17.65	7.09	6.73	8.33	7.99	4.14	1.65	6.40
2040	17.65	7.09	6.73	8.33	7.99	4.14	1.65	6.40
2042	17.65	7.09	6.73	8.33	7.99	4.14	1.65	6.40
2044	17.65	7.09	6.73	8.33	7.99	4.14	1.65	6.40
2046	17.65	7.09	6.73	8.33	7.99	4.14	1.65	6.40
2048	17.65	7.09	6.73	8.33	7.99	4.14	1.65	6.40
2050	17.65	7.09	6.73	8.33	7.99	4.14	1.65	6.40

Table 7.14: Hawai'i Island Forced Outage Rates for Thermal Resources (3 of 4)

Year	Kapua D27	Kanoelehua CT1	Keahole CT2	Puna CT3	Keahole CT4	Keahole CT5	Keahole ST	HEP CT1
2021	0.61	0.94	4.18	1.81	4.68	6.30	2.93	2.05
2022	0.61	0.94	4.18	1.81	4.68	6.30	2.93	2.05
2023	0.61	0.94	4.18	1.81	4.68	6.30	2.93	2.05
2024	0.61	0.94	4.18	1.81	4.68	6.30	2.93	2.05
2025	0.61	0.94	4.18	1.81	4.68	6.30	2.93	2.05
2026	0.61	0.94	4.18	1.81	4.68	6.30	2.93	2.05
2027	0.61	0.94	4.18	1.81	4.68	6.30	2.93	2.05



Integrated Grid Planning Inputs and Assumptions | August 2021 Update

2028	0.61	0.94	4.18	1.81	4.68	6.30	2.93	2.05
2030	0.61	0.94	4.18	1.81	4.68	6.30	2.93	2.05
2032	0.61	0.94	4.18	1.81	4.68	6.30	2.93	2.05
2034	0.61	0.94	4.18	1.81	4.68	6.30	2.93	2.05
2036	0.61	0.94	4.18	1.81	4.68	6.30	2.93	2.05
2038	0.61	0.94	4.18	1.81	4.68	6.30	2.93	2.05
2040	0.61	0.94	4.18	1.81	4.68	6.30	2.93	2.05
2042	0.61	0.94	4.18	1.81	4.68	6.30	2.93	2.05
2044	0.61	0.94	4.18	1.81	4.68	6.30	2.93	2.05
2046	0.61	0.94	4.18	1.81	4.68	6.30	2.93	2.05
2048	0.61	0.94	4.18	1.81	4.68	6.30	2.93	2.05
2050	0.61	0.94	4.18	1.81	4.68	6.30	2.93	2.05

Table 7.15: Hawai'i Island Forced Outage Rates for Thermal Resources (4 of 4)

Year	HEP CT2	HEP ST	PGV
%			
2021	4.22	2.52	9.22
2022	4.22	2.52	9.22
2023	4.22	2.52	9.22
2024	4.22	2.52	9.22
2025	4.22	2.52	9.22
2026	4.22	2.52	9.22
2027	4.22	2.52	9.22
2028	4.22	2.52	9.22
2029	4.22	2.52	9.22



<b>2030</b>	4.22	2.52	9.22
<b>2032</b>	4.22	2.52	9.22
<b>2034</b>	4.22	2.52	9.22
<b>2036</b>	4.22	2.52	9.22
<b>2038</b>	4.22	2.52	9.22
<b>2040</b>	4.22	2.52	9.22
<b>2042</b>	4.22	2.52	9.22
<b>2044</b>	4.22	2.52	9.22
<b>2046</b>	4.22	2.52	9.22
<b>2048</b>	4.22	2.52	9.22
<b>2050</b>	4.22	2.52	9.22

Table 7.16: Hawai'i Island Maintenance Outage Rates for Thermal Resources (1 of 4)

Year	Hill 5	Hill 6	Puna Steam	Kanoelehua D11	Waimea D12	Waimea D13	Waimea D14	Kanoelehua D15
%								
<b>2021</b>	5.33	9.83	10.77	4.76	0.17	0.32	0.12	1.04
<b>2022</b>	5.33	9.83	10.77	4.76	0.17	0.32	0.12	1.04
<b>2023</b>	5.33	9.83	10.77	4.76	0.17	0.32	0.12	1.04
<b>2024</b>	5.33	9.83	10.77	4.76	0.17	0.32	0.12	1.04
<b>2025</b>	5.33	9.83	10.77	4.76	0.17	0.32	0.12	1.04
<b>2026</b>	5.33	9.83	10.77	4.76	0.17	0.32	0.12	1.04
<b>2027</b>	5.33	9.83	10.77	4.76	0.17	0.32	0.12	1.04
<b>2028</b>	5.33	9.83	10.77	4.76	0.17	0.32	0.12	1.04
<b>2029</b>	5.33	9.83	10.77	4.76	0.17	0.32	0.12	1.04
<b>2030</b>	5.33	9.83	10.77	4.76	0.17	0.32	0.12	1.04
<b>2031</b>	5.33	9.83	10.77	4.76	0.17	0.32	0.12	1.04



2032	5.33	9.83	10.77	4.76	0.17	0.32	0.12	1.04
2034	5.33	9.83	10.77	4.76	0.17	0.32	0.12	1.04
2036	5.33	9.83	10.77	4.76	0.17	0.32	0.12	1.04
2038	5.33	9.83	10.77	4.76	0.17	0.32	0.12	1.04
2040	5.33	9.83	10.77	4.76	0.17	0.32	0.12	1.04
2042	5.33	9.83	10.77	4.76	0.17	0.32	0.12	1.04
2044	5.33	9.83	10.77	4.76	0.17	0.32	0.12	1.04
2046	5.33	9.83	10.77	4.76	0.17	0.32	0.12	1.04
2048	5.33	9.83	10.77	4.76	0.17	0.32	0.12	1.04
2050	5.33	9.83	10.77	4.76	0.17	0.32	0.12	1.04

Table 7.17: Hawai'i Island Maintenance Outage Rates for Thermal Resources (2 of 4)

Year									
%									
2021	0.42	0.99	1.11	0.93	0.79	0.72	0.22	0.17	
2022	0.42	0.99	1.11	0.93	0.79	0.72	0.22	0.17	
2023	0.42	0.99	1.11	0.93	0.79	0.72	0.22	0.17	
2024	0.42	0.99	1.11	0.93	0.79	0.72	0.22	0.17	
2025	0.42	0.99	1.11	0.93	0.79	0.72	0.22	0.17	
2026	0.42	0.99	1.11	0.93	0.79	0.72	0.22	0.17	
2027	0.42	0.99	1.11	0.93	0.79	0.72	0.22	0.17	
2028	0.42	0.99	1.11	0.93	0.79	0.72	0.22	0.17	
2029	0.42	0.99	1.11	0.93	0.79	0.72	0.22	0.17	
2030	0.42	0.99	1.11	0.93	0.79	0.72	0.22	0.17	
2031	0.42	0.99	1.11	0.93	0.79	0.72	0.22	0.17	



2032	0.42	0.99	1.11	0.93	0.79	0.72	0.22	0.17
2034	0.42	0.99	1.11	0.93	0.79	0.72	0.22	0.17
2036	0.42	0.99	1.11	0.93	0.79	0.72	0.22	0.17
2038	0.42	0.99	1.11	0.93	0.79	0.72	0.22	0.17
2040	0.42	0.99	1.11	0.93	0.79	0.72	0.22	0.17
2042	0.42	0.99	1.11	0.93	0.79	0.72	0.22	0.17
2044	0.42	0.99	1.11	0.93	0.79	0.72	0.22	0.17
2046	0.42	0.99	1.11	0.93	0.79	0.72	0.22	0.17
2048	0.42	0.99	1.11	0.93	0.79	0.72	0.22	0.17
2050	0.42	0.99	1.11	0.93	0.79	0.72	0.22	0.17

Table 7.18: Hawai'i Island Maintenance Outage Rates for Thermal Resources (3 of 4)

Year	Kapua D27	Kanoelehua CT1	Keahole CT2	Puna CT3	Keahole CT4	Keahole CT5	Keahole ST	HEP CT1
2021	0.29	2.64	1.79	2.65	2.96	3.09	1.09	2.46
2022	0.29	2.64	1.79	2.65	2.96	3.09	1.09	2.46
2023	0.29	2.64	1.79	2.65	2.96	3.09	1.09	2.46
2024	0.29	2.64	1.79	2.65	2.96	3.09	1.09	2.46
2025	0.29	2.64	1.79	2.65	2.96	3.09	1.09	2.46
2026	0.29	2.64	1.79	2.65	2.96	3.09	1.09	2.46
2027	0.29	2.64	1.79	2.65	2.96	3.09	1.09	2.46
2028	0.29	2.64	1.79	2.65	2.96	3.09	1.09	2.46
2029	0.29	2.64	1.79	2.65	2.96	3.09	1.09	2.46
2030	0.29	2.64	1.79	2.65	2.96	3.09	1.09	2.46
2031	0.29	2.64	1.79	2.65	2.96	3.09	1.09	2.46





2032	0.29	2.64	1.79	2.65	2.96	3.09	1.09	2.46
2034	0.29	2.64	1.79	2.65	2.96	3.09	1.09	2.46
2036	0.29	2.64	1.79	2.65	2.96	3.09	1.09	2.46
2038	0.29	2.64	1.79	2.65	2.96	3.09	1.09	2.46
2040	0.29	2.64	1.79	2.65	2.96	3.09	1.09	2.46
2042	0.29	2.64	1.79	2.65	2.96	3.09	1.09	2.46
2044	0.29	2.64	1.79	2.65	2.96	3.09	1.09	2.46
2046	0.29	2.64	1.79	2.65	2.96	3.09	1.09	2.46
2048	0.29	2.64	1.79	2.65	2.96	3.09	1.09	2.46
2050	0.29	2.64	1.79	2.65	2.96	3.09	1.09	2.46

Table 7.19: Hawai'i Island Maintenance Outage Rates for Thermal Resources (4 of 4)

Year	HEP CT2	HEP ST	PGV
%			
2021	2.93	1.07	3.84
2022	2.93	1.07	3.84
2023	2.93	1.07	3.84
2024	2.93	1.07	3.84
2025	2.93	1.07	3.84
2026	2.93	1.07	3.84
2027	2.93	1.07	3.84
2028	2.93	1.07	3.84
2029	2.93	1.07	3.84
2030	2.93	1.07	3.84
2031	2.93	1.07	3.84



2032	2.93	1.07	3.84
2033	2.93	1.07	3.84
2034	2.93	1.07	3.84
2035	2.93	1.07	3.84
2036	2.93	1.07	3.84
2037	2.93	1.07	3.84
2038	2.93	1.07	3.84
2039	2.93	1.07	3.84
2040	2.93	1.07	3.84
2041	2.93	1.07	3.84
2042	2.93	1.07	3.84
2043	2.93	1.07	3.84
2044	2.93	1.07	3.84
2045	2.93	1.07	3.84
2046	2.93	1.07	3.84
2047	2.93	1.07	3.84
2048	2.93	1.07	3.84
2049	2.93	1.07	3.84
2050	2.93	1.07	3.84

*Maui*

Table 7.20: Maui Minimum and Maximum Capacity for Thermal Resources

Unit <sup>89</sup>	Operating Minimum (Net MW)	Normal Top Load (Net MW)	Fuel Type
Kahului 1	2.26	4.71	IFO
Kahului 2	2.28	4.76	IFO
Kahului 3	3.00	11.50	IFO
Kahului 4	3.00	11.50	IFO
Maalaea 1	2.50	2.50	ULSD
Maalaea 2	2.50	2.50	ULSD
Maalaea 3	2.50	2.50	ULSD
Maalaea 4	1.86	5.51	Diesel
Maalaea 5	1.86	5.51	Diesel

<sup>89</sup> Kahului 1-4 units plan to retire in 24.



Maalaea 7	1.86	5.51	Diesel
Maalaea 9	1.86	5.48	Diesel
Maalaea 11	7.87	12.34	Diesel
Maalaea 13	7.87	12.34	Diesel
Maalaea X2	2.50	2.50	ULSD
Maalaea 15	3.73	13.38	-
Maalaea 17	5.93	21.47	Diesel
Maalaea 19	5.93	21.47	Diesel
Hana 2	0.00	0.97	ULSD

Table 7.21: Maui Heat Rate Coefficients for Thermal Resources

Unit	A Coefficient (MMBTU/hr)	B Coefficient (MMBTU/hr-MW)	C Coefficient (MMBTU/hr-MW <sup>2</sup> )	Average Heat Rate (BTU/KWH) <sup>90</sup>
Kahului 1	10.5570	12.0740	0.2260	
Kahului 2	8.1530	12.7150	0.2130	
Kahului 3	20.6320	11.1090	0.0270	
Kahului 4	30.2160	8.4170	0.2860	
Maalaea 1	0.0000	10.2878	0.0000	
Maalaea 2	0.0000	10.2878	0.0000	
Maalaea 3	0.0000	10.2878	0.0000	
Maalaea 4	12.4800	4.1590	0.7290	
Maalaea 5	12.4800	4.1590	0.7290	
Maalaea 6	12.4800	4.1590	0.7290	
Maalaea 7	12.4800	4.1590	0.7290	

<sup>90</sup> Hana 1 and 2 are primarily used as backup generation only for line maintenance and repair work in Hana. Therefore, they are modeled using an average heat rate, which is based on the maximum monthly usage over a 5-year historical period.



<b>Maalaea 9</b>	10.8880	4.7170	0.5900	
<b>Maalaea 11</b>	11.6310	6.7910	0.1320	
<b>Maalaea 13</b>	11.6310	6.7910	0.1320	
<b>Maalaea X2</b>	0.0000	10.2878	0.0000	
<b>Maalaea 15</b>	28.5852	20758.1000	0.1072	
<b>Maalaea 17</b>	48.5120	8439.0000	0.0120	
<b>Maalaea 19</b>	48.5120	8439.0000	0.0120	
<b>Hana 2</b>	-	-	-	11532.0000

Table 7.22: Maui Forced Outage Rates for Thermal Resources (1 of 3)

Year	Kahului 1	Kahului 2	Kahului 3	Kahului 4	Maalaea 1	Maalaea 2	Maalaea 3	Maalaea 4
2021			0.08	0.34	3.93	3.93	3.93	1.45
2022			0.08	0.34	3.93	3.93	3.93	1.45
2023								
2024					3.93	3.93	3.93	1.45
2025								
2026					3.93	3.93	3.93	1.45
2027								
2028					3.93	3.93	3.93	1.45
2029								
2030					3.93	3.93	3.93	1.45
2031								
2032					3.93	3.93	3.93	1.45
2033								
2034					3.93	3.93	3.93	1.45
2035								
2036					3.93	3.93	3.93	1.45



2037					3.93	3.93	3.93	1.45
2038					3.93	3.93	3.93	1.45
2039					3.93	3.93	3.93	1.45
2040					3.93	3.93	3.93	1.45
2041					3.93	3.93	3.93	1.45
2042					3.93	3.93	3.93	1.45
2043					3.93	3.93	3.93	1.45
2044					3.93	3.93	3.93	1.45
2045					3.93	3.93	3.93	1.45
2046					3.93	3.93	3.93	1.45
2047					3.93	3.93	3.93	1.45
2048					3.93	3.93	3.93	1.45
2049					3.93	3.93	3.93	1.45
2050					3.93	3.93	3.93	1.45

Table 7.23: Maui Forced Outage Rates for Thermal Resources (2 of 3)

Year	Maalaea 5	Maalaea 6	Maalaea 7	Maalaea 8	Maalaea 9	Maalaea 10	Maalaea 11	Maalaea 12
%								
2021	1.45	1.45	1.45	2.36	2.36	0.63	0.63	0.63
2022	1.45	1.45	1.45	2.36	2.36	0.63	0.63	0.63
2023	1.45	1.45	1.45	2.36	2.36	0.63	0.63	0.63
2024	1.45	1.45	1.45	2.36	2.36	0.63	0.63	0.63
2025	1.45	1.45	1.45	2.36	2.36	0.63	0.63	0.63
2026	1.45	1.45	1.45	2.36	2.36	0.63	0.63	0.63
2027	1.45	1.45	1.45	2.36	2.36	0.63	0.63	0.63
2028	1.45	1.45	1.45	2.36	2.36	0.63	0.63	0.63
2029	1.45	1.45	1.45	2.36	2.36	0.63	0.63	0.63
2030	1.45	1.45	1.45	2.36	2.36	0.63	0.63	0.63
2031	1.45	1.45	1.45	2.36	2.36	0.63	0.63	0.63
2032	1.45	1.45	1.45	2.36	2.36	0.63	0.63	0.63
2033	1.45	1.45	1.45	2.36	2.36	0.63	0.63	0.63
2034	1.45	1.45	1.45	2.36	2.36	0.63	0.63	0.63
2035	1.45	1.45	1.45	2.36	2.36	0.63	0.63	0.63
2036	1.45	1.45	1.45	2.36	2.36	0.63	0.63	0.63
2037	1.45	1.45	1.45	2.36	2.36	0.63	0.63	0.63
2038	1.45	1.45	1.45	2.36	2.36	0.63	0.63	0.63



2040	1.45	1.45	1.45	2.36	2.36	0.63	0.63	0.63
2042	1.45	1.45	1.45	2.36	2.36	0.63	0.63	0.63
2044	1.45	1.45	1.45	2.36	2.36	0.63	0.63	0.63
2046	1.45	1.45	1.45	2.36	2.36	0.63	0.63	0.63
2048	1.45	1.45	1.45	2.36	2.36	0.63	0.63	0.63
2050	1.45	1.45	1.45	2.36	2.36	0.63	0.63	0.63

Table 7.24: Maui Forced Outage Rates for Thermal Resources (3 of 3)

Year %	Maalaea 13	Maalaea X1	Maalaea X2	Maalaea 14	Maalaea 15	Maalaea 16	Maalaea 17	Maalaea 18	Maalaea 19
2021	0.63	3.93	3.93	0.16	0.41	0.16	0.49	0.30	0.49
2022	0.63	3.93	3.93	0.16	0.41	0.16	0.49	0.30	0.49
2023	0.63	3.93	3.93	0.16	0.41	0.16	0.49	0.30	0.49
2024	0.63	3.93	3.93	0.16	0.41	0.16	0.49	0.30	0.49
2025	0.63	3.93	3.93	0.16	0.41	0.16	0.49	0.30	0.49
2026	0.63	3.93	3.93	0.16	0.41	0.16	0.49	0.30	0.49
2027	0.63	3.93	3.93	0.16	0.41	0.16	0.49	0.30	0.49
2028	0.63	3.93	3.93	0.16	0.41	0.16	0.49	0.30	0.49
2029	0.63	3.93	3.93	0.16	0.41	0.16	0.49	0.30	0.49
2030	0.63	3.93	3.93	0.16	0.41	0.16	0.49	0.30	0.49
2031	0.63	3.93	3.93	0.16	0.41	0.16	0.49	0.30	0.49
2032	0.63	3.93	3.93	0.16	0.41	0.16	0.49	0.30	0.49
2033	0.63	3.93	3.93	0.16	0.41	0.16	0.49	0.30	0.49
2034	0.63	3.93	3.93	0.16	0.41	0.16	0.49	0.30	0.49
2035	0.63	3.93	3.93	0.16	0.41	0.16	0.49	0.30	0.49
2036	0.63	3.93	3.93	0.16	0.41	0.16	0.49	0.30	0.49
2037	0.63	3.93	3.93	0.16	0.41	0.16	0.49	0.30	0.49
2038	0.63	3.93	3.93	0.16	0.41	0.16	0.49	0.30	0.49
2039	0.63	3.93	3.93	0.16	0.41	0.16	0.49	0.30	0.49
2040	0.63	3.93	3.93	0.16	0.41	0.16	0.49	0.30	0.49



2042	0.63	3.93	3.93	0.16	0.41	0.16	0.49	0.30	0.49
2044	0.63	3.93	3.93	0.16	0.41	0.16	0.49	0.30	0.49
2046	0.63	3.93	3.93	0.16	0.41	0.16	0.49	0.30	0.49
2048	0.63	3.93	3.93	0.16	0.41	0.16	0.49	0.30	0.49
2050	0.63	3.93	3.93	0.16	0.41	0.16	0.49	0.30	0.49

Table 7.25: Maui Maintenance Outage Rates for Thermal Resources (1 of 3)

Year	Kahului 1	Kahului 2	Kahului 3	Kahului 4	Maalaea 1	Maalaea 2	Maalaea 3	Maalaea 4
2021			12.35	10.98	2.4	2.4	2.4	2.63
2022			10.98	10.98	2.4	2.4	2.4	2.63
2023								
2024					2.4	2.4	2.4	2.63
2025								
2026					2.4	7.88	2.4	2.63
2027								
2028					2.4	2.4	2.4	2.63
2029								
2030					2.4	2.4	5.96	2.63
2031								
2032					2.4	2.4	2.4	2.63
2033								
2034					2.4	2.4	2.4	2.63
2035								
2036					2.4	7.88	2.4	2.63
2037								
2038					2.4	2.4	2.4	2.63
2039								
2040					2.4	2.4	2.4	2.63
2041								
2042					2.4	2.4	2.4	2.63



2044					2.4	2.4	2.4	2.63
2045					2.4	2.4	2.4	2.63
2046					2.4	2.4	2.4	2.63
2047								
2048					2.4	2.4	2.4	2.63
2049								
2050					2.4	2.4	2.4	2.63

Year	Maalaea 5	Maalaea 6	Maalaea 7	Maalaea 8	Maalaea 9	Maalaea 10	Maalaea 11	Maalaea 12
%								
2021	2.63	10.3	2.63	1.24	1.24	2.54	18.98	25.28
2022	2.63	2.63	2.63	1.24	1.24	25.28	2.54	2.54
2023	2.63	19.62	2.63	1.24	1.24	2.54	2.54	2.54
2024	19.62	2.63	2.63	1.24	1.24	2.54	19.52	17.61
2025	2.63	2.63	2.63	1.24	1.24	17.61	2.54	2.54
2026	2.63	2.63	2.63	1.24	1.24	2.54	2.54	2.54
2027	2.63	2.63	2.63	1.24	1.24	2.54	19.52	17.61
2028	2.63	2.63	2.63	1.24	1.24	17.61	2.54	2.54
2029	2.63	2.63	19.62	1.24	1.24	2.54	2.54	2.54
2030	2.63	2.63	2.63	1.24	1.24	2.54	19.52	17.61
2031	2.63	2.63	2.63	16.3	18.22	17.61	2.54	2.54
2032	2.63	2.63	2.63	1.24	1.24	2.54	2.54	17.61
2033	2.63	2.63	2.63	1.24	1.24	17.61	19.52	2.54
2034	2.63	2.63	2.63	1.24	1.24	2.54	2.54	2.54
2035	2.63	2.63	2.63	1.24	1.24	2.54	2.54	17.61
2036	2.63	2.63	2.63	1.24	1.24	17.61	19.52	2.54
2037	2.63	2.63	2.63	1.24	1.24	2.54	2.54	2.54
2038	2.63	19.62	2.63	1.24	1.24	2.54	19.52	17.61
2039	2.63	2.63	2.63	1.24	1.24	17.61	2.54	2.54
2040	19.62	2.63	2.63	1.24	1.24	2.54	2.54	2.54
2041	2.63	2.63	2.63	1.24	1.24	2.54	17.61	17.61
2042	2.63	2.63	2.63	1.24	1.24	17.61	2.54	2.54
2043	2.63	2.63	2.63	1.24	1.24	2.54	2.54	2.54
2044	2.63	2.63	19.62	16.3	18.22	2.54	17.61	17.61





2046	2.63	2.63	2.63	1.24	1.24	17.61	2.54	2.54
2048	2.63	2.63	2.63	1.24	1.24	17.61	2.54	2.54
2050	2.63	2.63	2.63	1.24	1.24	17.61	2.54	2.54

Table 7.27: Maui Maintenance Outage Rates for Thermal Resources (3 of 3)

Year	Maalaea 13	Maalaea X1	Maalaea X2	Maalaea 14	Maalaea 15	Maalaea 16	Maalaea 17	Maalaea 18	Maalaea 19
2021	2.54	2.4	2.4	5.65	4.35	6.2	6.34	5.2	4.42
2022	25.28	2.4	2.4	5.65	12.02	5.65	4.42	5.2	4.42
2023	2.54	2.4	2.4	11.41	4.35	12.78	4.42	5.2	4.42
2024	2.54	2.4	2.4	7.3	4.35	5.65	4.42	5.2	4.42
2025	2.54	2.4	2.4	5.65	4.35	5.65	4.7	5.2	4.42
2026	17.61	2.4	2.4	5.65	13.94	5.65	4.42	5.2	4.42
2027	2.54	2.4	2.4	5.65	4.35	8.12	4.42	14.51	6.07
2028	2.54	5.69	5.69	9.22	4.35	12.78	6.34	5.2	4.42
2029	17.61	2.4	2.4	5.65	4.35	5.65	4.42	5.2	4.42
2030	2.54	2.4	2.4	6.48	4.35	5.65	4.42	5.2	7.98
2031	2.54	2.4	2.4	9.22	13.94	5.65	4.42	5.2	4.42
2032	17.61	2.4	2.4	5.65	4.35	5.65	4.42	14.51	4.42
2033	2.54	2.4	2.4	5.65	4.35	9.22	4.42	5.2	5.24
2034	2.54	2.4	2.4	5.65	4.35	6.48	4.42	5.2	4.42
2035	17.61	2.4	2.4	5.65	4.35	5.65	10.18	5.2	6.07
2036	2.54	2.4	2.4	8.12	13.94	5.65	4.42	5.2	4.42
2037	17.61	2.4	2.4	9.22	4.35	5.65	4.42	14.51	4.42
2038	2.54	5.69	4.04	5.65	4.35	9.22	4.42	5.2	4.42
2039	2.54	2.4	2.4	5.65	4.35	7.3	4.42	5.2	4.42
2040	17.61	2.4	2.4	5.65	4.35	5.65	7.98	5.2	5.24
2041	2.54	2.4	2.4	5.65	13.94	5.65	4.42	5.2	4.42
2042	2.54	2.4	2.4	9.22	4.35	5.65	4.42	12.87	4.42
2043	17.61	2.4	2.4	5.65	4.35	9.22	4.42	5.2	4.42
2044	2.54	2.4	2.4	5.65	4.35	5.65	4.42	5.2	4.42
2045	2.54	2.4	2.4	5.65	4.35	5.65	4.42	5.2	4.42
2046	2.54	2.4	2.4	5.65	4.35	5.65	4.42	5.2	4.42



2047	2.54	2.4	2.4	5.65	4.35	5.65	4.42	5.2	4.42
2048	2.54	2.4	2.4	5.65	4.35	5.65	4.42	5.2	4.42
2049	2.54	2.4	2.4	5.65	4.35	5.65	4.42	5.2	4.42
2050	2.54	2.4	2.4	5.65	4.35	5.65	4.42	5.2	4.42

*Moloka'i*

Table 7.28: Moloka'i Minimum and Maximum Capacity for Thermal Resources

Unit	Operating Minimum (Net MW)	Normal Top Load (Net MW)	Fuel Type
Palaau 01	0.31	1.25	ULSD
Palaau 02	0.31	1.25	ULSD
Palaau 03	0.25	0.97	ULSD
Palaau 04	0.25	0.97	ULSD
Palaau 05	0.25	0.97	ULSD
Palaau 06	0.25	0.97	ULSD
Palaau 07	0.66	2.20	ULSD
Palaau 08	0.66	2.20	ULSD
Palaau 09	0.66	2.20	ULSD
Palaau GT1	1.1	2.20	ULSD

Table 7.29: Moloka'i Heat Rate Coefficients for Thermal Resources

Unit	A Coefficient (MMBTU/hr)	B Coefficient (MMBTU/hr-MW)	C Coefficient (MMBTU/hr-MW <sup>2</sup> )
Palaau 01	1.3894	9.6947	-0.8835
Palaau 02	0.8831	10.4922	-1.7433
Palaau 03	5.4111	-4.6487	10.2493
Palaau 04	4.5017	1.8072	5.8410
Palaau 05	1.3975	9.3826	-0.3959
Palaau 06	1.5392	8.5616	0.1192
Palaau 07	3.1052	6.6925	0.8483
Palaau 08	2.0900	8.2860	0.2125
Palaau 09	2.1250	8.0170	0.3328
Palaau GT1	0.0000	18.8310	0.0000



Table 7.30: Moloka'i Forced Outage Rates for Thermal Resources

Year	Palaau 01	Palaau 02	Palaau 03	Palaau 04	Palaau 05	Palaau 06	Palaau 07	Palaau 08	Palaau 09	Palaau GT1
%										
2021	2.69	2.69	0.45	0.45	0.45	0.45	0.36	0.36	0.36	0
2022	2.69	2.69	0.45	0.45	0.45	0.45	0.36	0.36	0.36	0
2023	2.69	2.69	0.45	0.45	0.45	0.45	0.36	0.36	0.36	0
2024	2.69	2.69	0.45	0.45	0.45	0.45	0.36	0.36	0.36	0
2025	2.69	2.69	0.45	0.45	0.45	0.45	0.36	0.36	0.36	0
2026	2.69	2.69	0.45	0.45	0.45	0.45	0.36	0.36	0.36	0
2027	2.69	2.69	0.45	0.45	0.45	0.45	0.36	0.36	0.36	0
2028	2.69	2.69	0.45	0.45	0.45	0.45	0.36	0.36	0.36	0
2029	2.69	2.69	0.45	0.45	0.45	0.45	0.36	0.36	0.36	0
2030	2.69	2.69	0.45	0.45	0.45	0.45	0.36	0.36	0.36	0
2031	2.69	2.69	0.45	0.45	0.45	0.45	0.36	0.36	0.36	0
2032	2.69	2.69	0.45	0.45	0.45	0.45	0.36	0.36	0.36	0
2033	2.69	2.69	0.45	0.45	0.45	0.45	0.36	0.36	0.36	0
2034	2.69	2.69	0.45	0.45	0.45	0.45	0.36	0.36	0.36	0
2035	2.69	2.69	0.45	0.45	0.45	0.45	0.36	0.36	0.36	0
2036	2.69	2.69	0.45	0.45	0.45	0.45	0.36	0.36	0.36	0
2037	2.69	2.69	0.45	0.45	0.45	0.45	0.36	0.36	0.36	0
2038	2.69	2.69	0.45	0.45	0.45	0.45	0.36	0.36	0.36	0
2039	2.69	2.69	0.45	0.45	0.45	0.45	0.36	0.36	0.36	0
2040	2.69	2.69	0.45	0.45	0.45	0.45	0.36	0.36	0.36	0
2041	2.69	2.69	0.45	0.45	0.45	0.45	0.36	0.36	0.36	0
2042	2.69	2.69	0.45	0.45	0.45	0.45	0.36	0.36	0.36	0
2043	2.69	2.69	0.45	0.45	0.45	0.45	0.36	0.36	0.36	0
2044	2.69	2.69	0.45	0.45	0.45	0.45	0.36	0.36	0.36	0
2045	2.69	2.69	0.45	0.45	0.45	0.45	0.36	0.36	0.36	0
2046	2.69	2.69	0.45	0.45	0.45	0.45	0.36	0.36	0.36	0
2047	2.69	2.69	0.45	0.45	0.45	0.45	0.36	0.36	0.36	0
2048	2.69	2.69	0.45	0.45	0.45	0.45	0.36	0.36	0.36	0
2049	2.69	2.69	0.45	0.45	0.45	0.45	0.36	0.36	0.36	0
2050	2.69	2.69	0.45	0.45	0.45	0.45	0.36	0.36	0.36	0



Table 7.31: Moloka'i Maintenance Outage Rates for Thermal Resources

Year	Palaau 01	Palaau 02	Palaau 03	Palaau 04	Palaau 05	Palaau 06	Palaau 07	Palaau 08	Palaau 09	Palaau GT1
%										
2021	6.1	2.54	5.06	5.06	5.06	5.06	2.04	2.04	2.04	0
2022	2.54	13.77	5.06	5.06	5.06	5.06	2.04	2.04	13.27	1.64
2023	2.54	2.54	10.54	10.54	16.29	8.62	2.04	16.56	2.04	0
2024	8.02	2.54	5.06	5.06	5.06	10.54	16.56	2.04	2.04	0
2025	2.54	2.54	5.06	5.06	10.54	5.06	2.04	5.6	5.6	1.37
2026	2.54	8.02	5.06	8.62	5.06	5.06	5.6	2.04	2.04	0
2027	6.1	2.54	8.62	5.06	5.06	8.62	2.04	2.04	2.04	0
2028	2.54	2.54	5.06	5.06	8.62	5.06	2.04	5.6	5.6	0
2029	2.54	6.1	5.06	14.38	5.06	5.06	5.6	2.04	2.04	0
2030	8.02	2.54	10.54	5.06	5.06	10.54	2.04	2.04	2.04	1.37
2031	2.54	2.54	5.06	5.06	10.54	5.06	2.04	5.6	5.6	0
2032	2.54	8.02	5.06	8.62	5.06	5.06	5.6	2.04	2.04	0
2033	6.1	2.54	8.62	5.06	5.06	8.62	2.04	2.04	2.04	0
2034	2.54	2.54	5.06	5.06	8.62	5.06	2.04	5.6	5.6	0
2035	2.54	6.1	5.06	17.94	5.06	5.06	5.6	2.04	2.04	1.37
2036	11.58	2.54	10.54	5.06	5.06	14.1	2.04	2.04	2.04	0
2037	2.54	2.54	5.06	5.06	14.1	5.06	2.04	5.6	5.6	0
2038	2.54	8.02	5.06	8.62	5.06	5.06	5.6	2.04	2.04	0
2039	6.1	2.54	8.62	5.06	5.06	8.62	2.04	2.04	2.04	0
2040	2.54	2.54	5.06	5.06	8.62	5.06	2.04	5.6	5.6	1.37
2041	2.54	6.1	5.06	17.94	5.06	5.06	5.6	2.04	2.04	0
2042	11.58	2.54	10.54	5.06	5.06	10.54	2.04	2.04	2.04	0
2043	2.54	2.54	5.06	5.06	14.1	5.06	2.04	5.6	5.6	0
2044	2.54	8.02	5.06	8.62	5.06	5.06	5.6	2.04	2.04	0
2045	6.1	2.54	8.62	5.06	5.06	8.62	2.04	2.04	2.04	1.37
2046	2.54	2.54	5.06	5.06	5.06	5.06	2.04	2.04	2.04	0
2047	2.54	2.54	5.06	5.06	5.06	5.06	2.04	2.04	2.04	0
2048	2.54	2.54	5.06	5.06	5.06	5.06	2.04	2.04	2.04	0
2049	2.54	2.54	5.06	5.06	5.06	5.06	2.04	2.04	2.04	0
2050	2.54	2.54	5.06	5.06	5.06	5.06	2.04	2.04	2.04	0



Lānaʻi

Table 7.32: Lānaʻi Minimum and Maximum Capacity for Thermal Resources

Unit	Operating Minimum (Net MW)	Normal Top Load (Net MW)	Fuel Type
LL 1	0.5	1.0	ULSD
LL 2	0.5	1.0	ULSD
LL 3	0.5	1.0	ULSD
LL 4	0.5	1.0	ULSD
LL 5	0.5	1.0	ULSD
LL 6	0.5	1.0	ULSD
LL 7	0.3	2.2	ULSD
LL 8	0.3	2.2	ULSD
CHP	0.83	0.83	ULSD

Table 7.33: Lānaʻi Heat Rate Coefficients for Thermal Resources

Unit	A Coefficient (MMBTU/hr)	B Coefficient (MMBTU/hr-MW)	C Coefficient (MMBTU/hr-MW <sup>2</sup> )
LL 1	1.9016	6.6910	1.9235
LL 2	1.9054	6.9548	2.1515
LL 3	0.9656	10.5671	-0.8720
LL 4	0.6577	11.5526	-1.6507
LL 5	1.2913	9.0183	0.3364
LL 6	0.9302	10.1353	-0.6496
LL 7	3.4169	6.6148	0.6626
LL 8	3.1015	7.1223	0.3705
CHP	0	11.380	0

Table 7.34: Lānaʻi Forced Outage Rates for Thermal Resources

Year	LL 1	LL 2	LL 3	LL 4	LL 5	LL 6	LL 7	LL 8	CHP
%									
2021	4.93	4.93	4.93	4.93	4.93	4.93	4.30	4.30	16.35
2022	4.93	4.93	4.93	4.93	4.93	4.93	4.30	4.30	16.35
2023	4.93	4.93	4.93	4.93	4.93	4.93	4.30	4.30	16.35
2024	4.93	4.93	4.93	4.93	4.93	4.93	4.30	4.30	16.35
2025	4.93	4.93	4.93	4.93	4.93	4.93	4.30	4.30	16.35



2026	4.93	4.93	4.93	4.93	4.93	4.93	4.30	4.30	16.35
2027	4.93	4.93	4.93	4.93	4.93	4.93	4.30	4.30	16.35
2028	4.93	4.93	4.93	4.93	4.93	4.93	4.30	4.30	16.35
2029	4.93	4.93	4.93	4.93	4.93	4.93	4.30	4.30	16.35
2030	4.93	4.93	4.93	4.93	4.93	4.93	4.30	4.30	16.35
2031	4.93	4.93	4.93	4.93	4.93	4.93	4.30	4.30	16.35
2032	4.93	4.93	4.93	4.93	4.93	4.93	4.30	4.30	16.35
2033	4.93	4.93	4.93	4.93	4.93	4.93	4.30	4.30	16.35
2034	4.93	4.93	4.93	4.93	4.93	4.93	4.30	4.30	16.35
2035	4.93	4.93	4.93	4.93	4.93	4.93	4.30	4.30	16.35
2036	4.93	4.93	4.93	4.93	4.93	4.93	4.30	4.30	16.35
2037	4.93	4.93	4.93	4.93	4.93	4.93	4.30	4.30	16.35
2038	4.93	4.93	4.93	4.93	4.93	4.93	4.30	4.30	16.35
2039	4.93	4.93	4.93	4.93	4.93	4.93	4.30	4.30	16.35
2040	4.93	4.93	4.93	4.93	4.93	4.93	4.30	4.30	16.35
2041	4.93	4.93	4.93	4.93	4.93	4.93	4.30	4.30	16.35
2042	4.93	4.93	4.93	4.93	4.93	4.93	4.30	4.30	16.35
2043	4.93	4.93	4.93	4.93	4.93	4.93	4.30	4.30	16.35
2044	4.93	4.93	4.93	4.93	4.93	4.93	4.30	4.30	16.35
2045	4.93	4.93	4.93	4.93	4.93	4.93	4.30	4.30	16.35
2046	4.93	4.93	4.93	4.93	4.93	4.93	4.30	4.30	16.35
2047	4.93	4.93	4.93	4.93	4.93	4.93	4.30	4.30	16.35
2048	4.93	4.93	4.93	4.93	4.93	4.93	4.30	4.30	16.35
2049	4.93	4.93	4.93	4.93	4.93	4.93	4.30	4.30	16.35
2050	4.93	4.93	4.93	4.93	4.93	4.93	4.30	4.30	16.35

Table 7.35: Lānaʻi Maintenance Outage Rates for Thermal Resources

Year	LL 1	LL 2	LL 3	LL 4	LL 5	LL 6	LL 7	LL 8	CHP
%									
2021	1.57	1.57	1.57	1.57	1.57	1.57	3.04	3.04	8.12
2022	1.57	1.57	1.57	1.57	1.57	1.57	3.04	3.04	8.12
2023	1.57	1.57	1.57	1.57	1.57	1.57	3.04	3.04	8.12
2024	1.57	1.57	1.57	1.57	1.57	1.57	3.04	3.04	8.12
2025	1.57	1.57	1.57	1.57	1.57	1.57	3.04	3.04	8.12
2026	1.57	1.57	1.57	1.57	1.57	1.57	3.04	3.04	8.12
2027	1.57	1.57	1.57	1.57	1.57	1.57	3.04%	3.04	8.12
2028	1.57	1.57	1.57	1.57	1.57	1.57	3.04	3.04	8.12



2029	1.57	1.57	1.57	1.57	1.57	1.57	3.04	3.04	8.12
2030	1.57	1.57	1.57	1.57	1.57	1.57	3.04	3.04	8.12
2031	1.57	1.57	1.57	1.57	1.57	1.57	3.04	3.04	8.12
2032	1.57	1.57	1.57	1.57	1.57	1.57	3.04	3.04	8.12
2033	1.57	1.57	1.57	1.57	1.57	1.57	3.04	3.04	8.12
2034	1.57	1.57	1.57	1.57	1.57	1.57	3.04	3.04	8.12
2035	1.57	1.57	1.57	1.57	1.57	1.57	3.04	3.04	8.12
2036	1.57	1.57	1.57	1.57	1.57	1.57	3.04	3.04	8.12
2037	1.57	1.57	1.57	1.57	1.57	1.57	3.04	3.04	8.12
2038	1.57	1.57	1.57	1.57	1.57	1.57	3.04	3.04	8.12
2039	1.57	1.57	1.57	1.57	1.57	1.57	3.04	3.04	8.12
2040	1.57	1.57	1.57	1.57	1.57	1.57	3.04	3.04	8.12
2041	1.57	1.57	1.57	1.57	1.57	1.57	3.04	3.04	8.12
2042	1.57	1.57	1.57	1.57	1.57	1.57	3.04	3.04	8.12
2043	1.57	1.57	1.57	1.57	1.57	1.57	3.04	3.04	8.12
2044	1.57	1.57	1.57	1.57	1.57	1.57	3.04	3.04	8.12
2045	1.57	1.57	1.57	1.57	1.57	1.57	3.04	3.04	8.12
2046	1.57	1.57	1.57	1.57	1.57	1.57	3.04	3.04	8.12
2047	1.57	1.57	1.57	1.57	1.57	1.57	3.04	3.04	8.12
2048	1.57	1.57	1.57	1.57	1.57	1.57	3.04	3.04	8.12
2049	1.57	1.57	1.57	1.57	1.57	1.57	3.04	3.04	8.12
2050	1.57	1.57	1.57	1.57	1.57	1.57	3.04	3.04	8.12



## 8 Thermal Generating Unit Removal from Service Schedules

The planned removal from service schedules for O’ahu, Hawai’i Island, and Maui are provided below. These schedules represent initial assumptions made on the timing for the removal of utility-owned, thermal generating units. This does not imply that the Company will retire these units in the years in which the model does not dispatch them. Actual retirement decisions are operational decisions that will be made at a later date based on a number of factors, including whether sufficient resources have been acquired and are in service, ancillary services provided by these generators have been sufficiently replaced, and after consideration for reliability and resilience factors, among others.

The planning analyses in the Grid Needs Assessment may deem it prudent to delay certain units’ removal to address shortfalls in grid services, including Energy Reserve Margin. The order in which units are removed may be further adjusted to account for flexibility needs and unit age.

Table 8.1: Planned Removal from Service Assumptions for O’ahu, Hawai’i Island, and Maui

Island	O’ahu	Hawai’i Island	Maui
<b>2024</b>	Waiau 3-4 Removed from Service		
<b>2025</b>		Puna Steam Removed from Service	
<b>2027</b>	Waiau 5-6 Removed from Service	Hill 5-6 Removed from Service	
<b>2029</b>	Kahe 1-2 Removed from Service		
<b>2030</b>			Maalaea 4-9 Removed from Service
<b>2033</b>	Waiau 7-8 Removed from Service		
<b>2037</b>	Kahe 3-4 Removed from Service		
<b>2046</b>	Kahe 5-6 Removed from Service		





## 9 Variable Renewable, Storage, and Grid Service Resource Portfolios

In addition to the thermal generating units, Hawaiian Electric has a diverse range of variable renewable resources including wind, solar, and hydro in its portfolio. Several upcoming projects will also add storage to the resource mix, paired with solar or as a standalone resource. The following resources are assumed to be online in the RESOLVE and PLEXOS models and are either existing resources that are currently online or have had an application submitted for approval. More information on the status of these new renewable energy projects can be found on the Renewable Project Status Board.<sup>91</sup> The year in service shown for the Stage 1 and Stage 2 RFP projects have been rounded to the nearest beginning of year. The planned resource portfolio will be updated for the projects resulting from the Community-Based Renewable Energy (CBRE) Phase 2 once they are known. Grid Services RFP projects noted below are assumed to be online at partial capacity in 2021 and ramp to their full capacity by 2023.

### O’ahu

Table 9.1: O’ahu Variable Renewable, Storage, and Grid Service Resources

Unit	Year in Service	Capacity (MW)	Storage Capacity (MWh)	Capacity Factor (%)
Kapolei Sustainable Energy Park	2012	1.0	-	21.9%
Kalaeloa Solar Two	2013	5.0	-	25.7%
Kalaeloa Renewable Energy Park	2014	5.0	-	20.5%
Kahuku Wind	2011	30.0	-	27.2%
Kawailoa Wind	2013	69.0	-	19.7%
West Loch	2019	20.0	-	25.1%
Lanikuhana Solar	2019	14.7	-	27.1%
Waipio PV	2019	45.9	-	27.1%
Kawailoa Solar	2019	49.0	-	27.1%
Na Pua Makani	2020	24.0	-	42.5%
Waianae Solar	2017	27.6	-	27.1%
Feed-In-Tariff Tier 1 and 2		24.8	-	19.3%
Feed-In-Tariff Tier 3		20.0	-	
Aloha Solar Energy Fund 1 & 2	2020	10.0	-	19.3%
Mauka FIT 1	2020	3.5	-	19.3%
Waihonu Solar	2016	6.5	-	19.3%

<sup>91</sup> See <https://www.hawaiianelectric.com/clean-energy-hawaii/our-clean-energy-portfolio/renewable-project-status-board>



CBRE Phase 1	2021	5.0	-	24.5%
<b>Stage 1</b>				
Hoohana Solar 1	2024	52.0		
AES West Oahu Solar	2023	12.5	50.0	25.2%
Mililani 1 Solar	2023	39.0	156.0	27.2%
Waiawa Solar Power	2023	36.0	144.0	27.9%
<b>Stage 2</b>				
Kupehau Solar	2022	60.0	240.0	21.2%
<b>Mountain View Solar</b>				
	2023	7.0	35.0	17.3%
<b>Mahi Solar</b>				
	2024	120.0	480.0	25.8%
<b>Grid Services RFP</b>				
<b>Load Reduce</b>				
	2021	26.3	-	-
<b>Load Build 3</b>				
	2023	60	-	-
<b>FFR 3</b>				
	2023	12	-	-
<b>Demand Response</b>				
Fast Demand Response (FDR)	2018	5.5	-	-
Residential Direct Load Control	2018	13.2		
Commercial Direct Load Control	2018	7.8	-	-
Small Business Direct Load Control				

*Hawai'i Island*

Unit	Year in Service	Capacity (MW)	Storage Capacity (MWh)	Capacity Factor (%)
Small Hydros		0.2	-	85.7%
Wailuku Hydro	1993	12.1	-	18.9%
HRD Wind	2006	10.5	-	42.4%
Tawhiri	2007	20.5		63.6%
SIA Wind		3.5	-	30.3%



Feed-In-Tariff		9.1		
Puueo Hydro	2005	3.3	-	54.8%
CBRE Phase 1	2022	1.0	-	16.9%
<b>Stage 1 RFP</b>				
Waikoloa Solar	2023	30.0	120.0	30.9%
<b>Stage 2 RFP</b>				
Puako Solar	2024	60.0	240.0	32.2%
		12.0	12.0	
<b>Grid Services RFP</b>				
FFR	2023	6.0		
Load Reduce	2023	4.0	-	-
Load Build		3.2		

*Maui*

Unit	Year in Service	Capacity (MW)	Storage Capacity (MWh)	Capacity Factor (%)
Feed-In-Tariff		6.75	-	17%
Kaheawa Wind Farm I	2006	30.0	-	43%
Kaheawa Wind Farm II	2012	21.0	-	47%
Auwahi Wind Farm	2012	21.0	-	51%
South Maui Renewable Resources	2018	2.9	-	29%
Kuia Solar	2018	2.9	-	29%
CBRE Phase 1	2021	0.025	-	28%
CBRE Phase 2	2026	33.475	-	-
<b>Stage 1 RFP</b>				
Kuihelani	2024	60.0	240.0	31%
Paeahu Solar	2023	15.0	60.0	31%
<b>Stage 2 RFP</b>				
Kahana Solar	2024	20.0	80.0	43%
Pulehu Solar	2023	40.0	160.0	31%
Waena BESS	2023	40.0	160.0	-
<b>Grid Services RFP</b>				



Load Build	2023	2.0	-	-
FFR1	2023	6.1	-	-
<u>Demand Response</u>				
Fast Demand Response	2021	4.9	-	-

*Moloka'i*

Table 9.4: Moloka'i Variable Renewable, Storage, and Grid Service Resources

Unit	Year in Service	Capacity (MW)	Storage Capacity (MWh)	Capacity Factor (%)
CBRE Phase 1	2021	0.25	-	27.60%
		2.50		

*Lāna'i*

Table 9.5: Lāna'i Variable Renewable, Storage, and Grid Service Resources

Unit	Year in Service	Capacity (MW)	Storage Capacity (MWh)	Capacity Factor (%)
Lanai Sustainability Research	2009	1.2	-	26.15%
CBRE Phase 2	2026	3.0	-	-



## 10 Location-Based Forecasts

To develop location-based circuit level load and DER technology forecasts, the Company has adopted LoadSEER as a key component to advancing the distribution planning methodology. On O‘ahu, LoadSEER is already being used to develop distribution-level circuit forecasts, and the Company targets deployment on Maui and Hawai‘i Island in early 2022. This electric load forecasting software uses the Company’s corporate load forecasts and a multitude of other geospatial inputs to create forecasts at the circuit and transformer level. The Company’s use of LoadSEER is discussed in the Distribution Planning Methodology<sup>92</sup> developed in collaboration with stakeholder and customer engagement through the Distribution Planning Working Group.

---

### 10.1 STAGES OF THE DISTRIBUTION PLANNING PROCESS

The Distribution Planning Methodology is comprised of four stages: forecast, analysis, solution options, and evaluation.

1. **Forecast Stage:** Develop circuit-level forecasts based on the corporate demand forecast.
2. **Analysis Stage:** Determine the adequacy of the distribution system.
3. **Solution Options Stage:** Identify the grid needs requirements.
4. **Evaluation Stage:** Evaluation of solutions.

---

<sup>92</sup> See

[https://www.hawaiielectric.com/documents/clean\\_energy\\_hawaii/integrated\\_grid\\_planning/stakeholder\\_engagement/working\\_groups/distribution\\_planning/20200602\\_dpwg\\_distribution\\_planning\\_methodology.pdf](https://www.hawaiielectric.com/documents/clean_energy_hawaii/integrated_grid_planning/stakeholder_engagement/working_groups/distribution_planning/20200602_dpwg_distribution_planning_methodology.pdf)





Figure 10-1 : Stages of the Distribution Planning Process

## 10.2 LOADSEER FORECASTING ENGINE

LoadSEER is an electric load forecasting software that creates circuit-level forecasts by combining historical SCADA and weather data along with forecasted new load, DER, EV, and EE spatially allocated throughout the system. LoadSEER spatially allocates these layers at the distribution level through an agent-based simulation that determines the likelihood that each of these types will be adopted at each service point. This process refines the system level forecast and provides location information such as customer consumption, historical DER adoption, census tract data, among others, with circuit-level forecasts. LoadSEER constrains the total amount that gets allocated for each of these layers by an incremental system level limit for each layer. The system level constraint is based on the corporate DER forecast. The resulting DER forecast allocation provides the feeder-level forecasted DER growth that is needed to calculate the adjusted DER forecast and thus the total anticipated DER by feeder.

As shown in Figure 10-2, LoadSEER is used in the Forecast and Analysis stages within the distribution planning process. As described above and presented in the June 4, 2021 IGP Technical Conference and June 17, 2021 Stakeholder Technical Working Group meetings, the Corporate forecast is used as an input to the LoadSEER circuit-forecasting process. The Corporate forecasted load, DER, EV, and EE layers are spatially allocated to the distribution circuits (see Figure 10-3). The hosting capacity analysis provided in the *Distribution DER Hosting Capacity Grid Needs* report disaggregated DER layers by residential and commercial for its analysis. System load layers used in LoadSEER are split by rate classes<sup>93</sup> R, DS, F, G, J, and P, and will be included in the process for the Grid Needs Review Point filing.

The resulting circuit level forecasts are the basis for distribution planning analyses. Currently the resulting circuit level forecasts are not used to inform the Corporate-level forecast. However, the circuit-level forecast is used as part of the hosting

<sup>93</sup> See <https://www.hawaiianelectric.com/billing-and-payment/rates-and-regulations/oahu-rates>



capacity analysis to determine the distribution grid needs to accommodate the corporate-level DER forecast.

A hosting capacity analysis was completed based on the 5-year forecasted DER, which is discussed in Section 11 and the Company’s *Distribution DER Hosting Capacity Grid Needs* report. The Distribution DER Hosting Capacity Grid Needs report explains how LoadSEER is used to allocate the Corporate DER forecast to the circuit level to perform the circuit level hosting capacity analysis. A circuit-level load forecast for all islands<sup>94</sup> will be provided on October 1, 2021 in the Grid Needs Review Point.

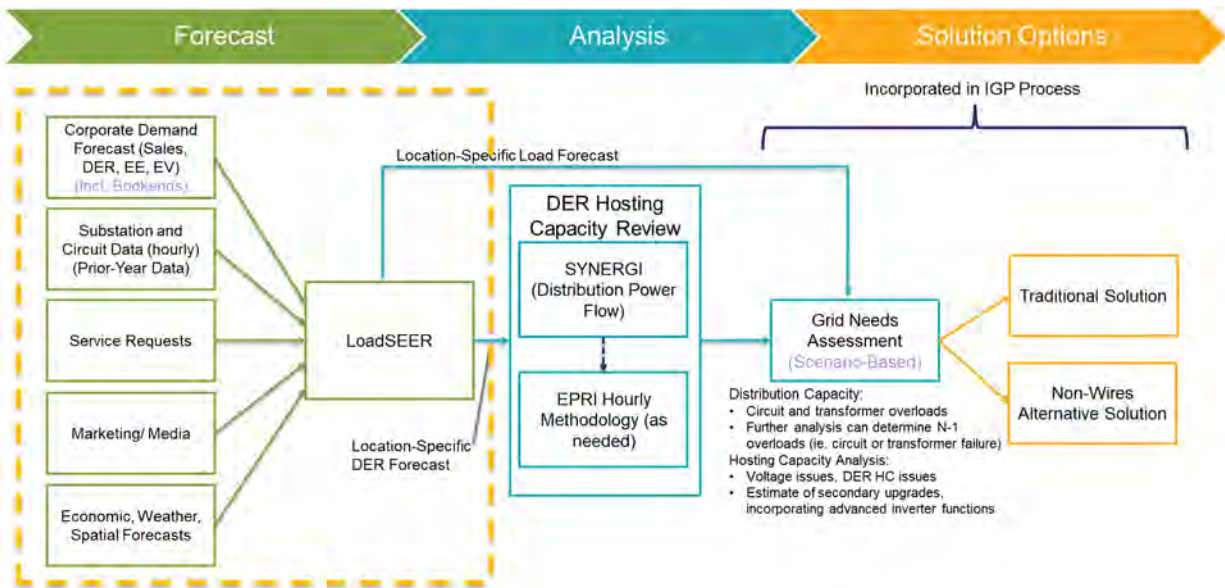

Figure 10-2: LoadSEER in Distribution Planning Process

<sup>94</sup> LoadSEER implemented on O’ahu only.



## LoadSEER: Disaggregation of Corporate Forecast

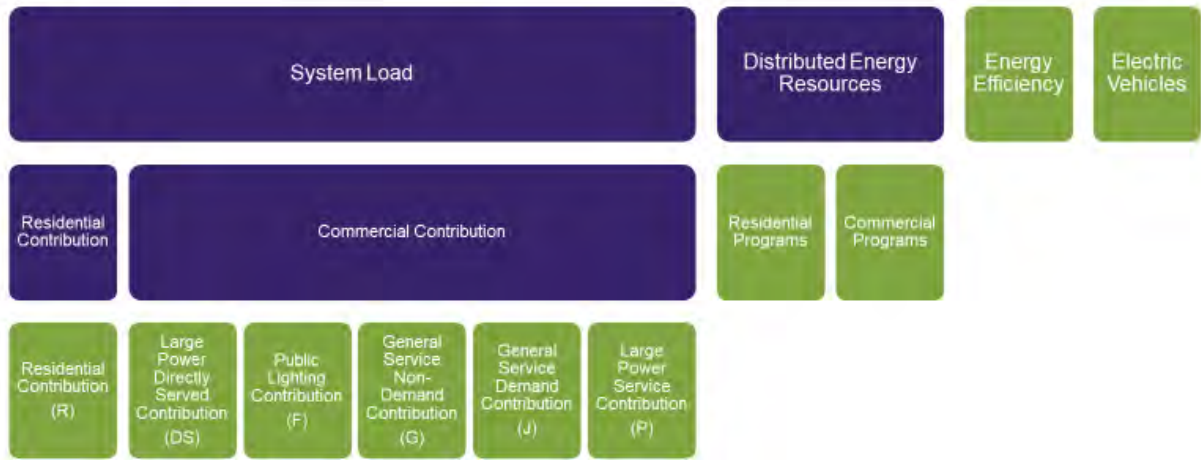

Figure 10-3: LoadSEER Layers





## 11 Hosting Capacity Analysis

Filed alongside this report is the Company's *Distribution DER Hosting Capacity Grid Needs* report, which is a wide-scale distribution-level analysis that focuses on hosting capacity grid needs identified for the next five years (year 2021 through 2025) driven by the anticipated increase in DER on distribution circuits based on the current market DER forecast provided the 2020 Integrated Grid Planning Inputs and Assumptions March 2021 Update.<sup>95</sup> The intent of the analysis is to update circuit hosting capacities and identify the grid needs at the local distribution level to accommodate the market DER forecast at the system level allocated down to the circuit level. The effort to complete the analysis was performed in parallel with ongoing stakeholder engagement and IGP working group discussions, as discussed in Section 2, and therefore does not reflect the latest forecast assumptions discussed in Section 4.1.1.

As a result of this analysis:

- 576 circuits do not require grid needs:
  - 511 circuits can accommodate the 5-year DER forecast with existing hosting capacity.
  - 65 circuits can accommodate the 5-year DER forecast through updated hosting capacity without modifications.
- 44 circuits require grid needs at the primary distribution circuit-level:
  - 32 circuits can accommodate through minimal investment (e.g., LTC setting changes).
  - 12 circuits require solutions/mitigations, which will serve as an input to the Grid Needs Assessment stage of the IGP process. Total estimated costs for traditional solutions on all islands is \$2.7 M.

Updated hosting capacities and implementation of the above mitigations and solutions will provide an increase of hosting capacity of 16 MW on O'ahu, 18 MW on Hawai'i Island, 37 MW on Maui Island, 0.02 MW on Lana'i, and 0.5 MW on Moloka'i.

Consistent with the *Non-Wires Opportunity Evaluation Methodology*<sup>96</sup>, cost estimates are developed for solutions that require significant upgrades. These estimates will be used as inputs to the Grid Needs Assessment stage of the IGP process to evaluate if they qualify as an NWA opportunity, and if so, be procured as part of

<sup>95</sup> See

[https://www.hawaiianelectric.com/documents/clean\\_energy\\_hawaii/integrated\\_grid\\_planning/stakeholder\\_engagement/working\\_groups/forecast\\_assumptions/20210330\\_wg\\_fa\\_deliverable\\_draft.pdf](https://www.hawaiianelectric.com/documents/clean_energy_hawaii/integrated_grid_planning/stakeholder_engagement/working_groups/forecast_assumptions/20210330_wg_fa_deliverable_draft.pdf)

<sup>96</sup> Hawaiian Electric, *Non-Wires Opportunity Evaluation Methodology* June 2020,

[https://www.hawaiianelectric.com/documents/clean\\_energy\\_hawaii/integrated\\_grid\\_planning/stakeholder\\_engagement/working\\_groups/distribution\\_planning/20200602\\_dpwg\\_non\\_wires\\_opportunity\\_evaluation\\_methodology.pdf](https://www.hawaiianelectric.com/documents/clean_energy_hawaii/integrated_grid_planning/stakeholder_engagement/working_groups/distribution_planning/20200602_dpwg_non_wires_opportunity_evaluation_methodology.pdf)



the overarching IGP process where a portfolio of solutions will be selected to address the identified grid needs.

As described in the June 2021 Work Plan<sup>97</sup>, the Company anticipates filing a Grid Needs Assessment update deliverable by October 1, 2021 that includes a refresh of the hosting capacity analysis using the updated forecast assumptions as well as additional modeling and analysis to identify grid needs driven by other DER forecast sensitivities, such as the high and low DER bookends currently being developed.

---

<sup>97</sup> Hawaiian Electric Updated Timeline and Stakeholder Engagement Plan filed on June 18, 2021 in Docket No. 2018-0165 at page 7.



# Appendix A: Nominal Resource Cost Forecasts (2020 – 2050)

Table 11.1: Capital and O&M Costs for Resource Options (Paired Grid-Scale PV, Standalone Grid-Scale PV, Commercial-Scale PV)

Year	Paired Grid-Scale PV (Single axis tracking)		Standalone Grid-Scale PV (Single axis tracking)		Commercial-Scale PV	
	Capital (\$/kW)	O&M (\$/kW-year)	Capital (\$/kW)	O&M (\$/kW-year)	Capital (\$/kW)	O&M (\$/kW-year)
2020	1,381	28	2,105	28	2,067	26
2021	1,343	28	2,048	28	2,004	25
2022	1,303	28	1,986	28	1,936	25
2023	1,348	28	2,056	28	1,984	25
2024	1,629	27	2,484	27	2,252	24
2025	1,579	27	2,408	27	2,153	24
2026	1,526	27	2,326	27	2,048	23
2027	1,539	27	2,346	27	2,021	22
2028	1,476	26	2,250	26	1,918	22
2029	1,409	26	2,148	26	1,808	21
2030	1,338	25	2,040	25	1,692	20
2031	1,357	26	2,069	26	1,712	21
2032	1,376	26	2,098	26	1,731	21
2033	1,396	27	2,128	27	1,750	21
2034	1,415	27	2,157	27	1,769	22
2035	1,435	28	2,187	28	1,789	22
2036	1,454	28	2,217	28	1,808	22
2037	1,474	29	2,247	29	1,827	23
2038	1,494	29	2,278	29	1,846	23
2039	1,514	30	2,309	30	1,864	23
2040	1,535	30	2,339	30	1,883	24
2041	1,555	31	2,370	31	1,902	24
2042	1,575	31	2,402	31	1,920	24
2043	1,596	32	2,433	32	1,938	25
2044	1,617	33	2,465	33	1,956	25
2045	1,637	33	2,496	33	1,974	26



Year	Paired Grid-Scale PV (Single axis tracking)		Standalone Grid-Scale PV (Single axis tracking)		Commercial-Scale PV	
	Capital (\$/kW)	O&M (\$/kW-year)	Capital (\$/kW)	O&M (\$/kW-year)	Capital (\$/kW)	O&M (\$/kW-year)
2046	1,658	34	2,528	34	1,991	26
2047	1,679	34	2,560	34	2,009	26
2048	1,700	35	2,592	35	2,026	27
2049	1,721	36	2,624	36	2,042	27
2050	1,743	36	2,657	36	2,059	27

Table 11.2: Capital and O&M Costs for Resource Options (Residential PV, Onshore Wind, Distributed Wind)

Year	Residential PV		Onshore Wind		Distributed Wind	
	Capital (\$/kW)	O&M (\$/kW-year)	Capital (\$/kW)	O&M (\$/kW-year)	Capital (\$/kW)	O&M (\$/kW-year)
2020	2,923	40	9,618	52	7,834	49
2021	2,766	39	9,530	52	7,761	50
2022	2,730	38	11,944	53	7,682	51
2023	2,749	36	11,807	54	8,005	51
2024	3,628	35	11,658	55	10,136	52
2025	3,400	33	11,496	55	9,995	53
2026	3,160	31	11,320	56	9,841	54
2027	3,028	30	11,597	57	9,676	54
2028	2,750	28	11,383	58	9,497	55
2029	2,457	26	11,152	59	9,304	56
2030	2,149	24	10,905	59	9,097	57
2031	2,175	24	11,047	60	9,216	57
2032	2,201	24	11,190	61	9,335	58



Year	Residential PV		Onshore Wind		Distributed Wind	
	Capital (\$/kW)	O&M (\$/kW-year)	Capital (\$/kW)	O&M (\$/kW-year)	Capital (\$/kW)	O&M (\$/kW-year)
2033	2,226	25	11,334	62	9,455	59
2034	2,252	25	11,478	63	9,576	60
2035	2,278	25	11,623	64	9,697	61
2036	2,303	26	11,768	65	9,818	62
2037	2,329	26	11,914	66	9,940	63
2038	2,355	27	12,061	67	10,063	64
2039	2,380	27	12,207	68	10,185	65
2040	2,406	27	12,354	69	10,308	66
2041	2,431	28	12,501	70	10,431	67
2042	2,456	28	12,649	71	10,554	68
2043	2,481	29	12,796	72	10,677	69
2044	2,506	29	12,943	73	10,800	70
2045	2,531	30	13,091	75	10,923	71
2046	2,555	30	13,238	76	11,046	72
2047	2,579	30	13,385	77	11,169	73
2048	2,603	31	13,532	78	11,291	74
2049	2,627	31	13,678	79	11,413	75
2050	2,651	32	13,823	80	11,535	76



Table 11.3: Capital and O&M Costs for Resource Options (Offshore Wind North, Offshore Wind East, Offshore Wind South)

Year	Offshore Wind North		Offshore Wind East		Offshore Wind South	
	Capital (\$/kW)	O&M (\$/kW-year)	Capital (\$/kW)	O&M (\$/kW-year)	Capital (\$/kW)	O&M (\$/kW-year)
2020	2,976	73	2,705	73	2,607	69
2021	2,863	68	2,597	69	2,501	65
2022	2,800	65	2,536	65	2,441	62
2023	2,764	63	2,501	63	2,406	60
2024	2,745	61	2,481	62	2,386	58
2025	2,738	60	2,472	60	2,377	57
2026	4,069	59	3,686	59	3,549	56
2027	4,082	58	3,695	58	3,557	55
2028	4,102	58	3,711	58	3,572	55
2029	4,129	57	3,734	57	3,593	54
2030	4,162	57	3,761	57	3,619	54
2031	4,200	57	3,794	57	3,649	54
2032	4,242	56	3,830	56	3,684	54
2033	4,288	56	3,871	56	3,722	54
2034	4,338	56	3,914	56	3,764	53
2035	4,391	56	3,961	56	3,808	53
2036	4,448	56	4,011	56	3,856	54
2037	4,508	56	4,063	56	3,906	54
2038	4,570	56	4,118	56	3,958	54
2039	4,635	56	4,176	57	4,014	54
2040	4,704	57	4,236	57	4,071	54
2041	4,774	57	4,299	57	4,131	54
2042	4,848	57	4,364	57	4,193	55
2043	4,923	57	4,431	57	4,257	55
2044	5,002	57	4,500	58	4,324	55
2045	5,083	58	4,572	58	4,393	55
2046	5,166	58	4,646	58	4,463	56
2047	5,252	58	4,722	59	4,537	56
2048	5,340	59	4,801	59	4,612	56
2049	5,431	59	4,882	59	4,689	57
2050	5,525	60	4,965	60	4,769	57



Table 11.4: Capital and O&M Costs for Resource Options (Grid-Scale Storage, Pumped Storage Hydro)

Year	Grid-Scale Storage			Pumped Storage Hydro		
	Balance of System (\$/kW)	Modules (\$/kWh)	O&M (\$/kW-year)	Capital (\$/kW)	O&M (\$/kW-year)	Var O&M (\$/MWH)
2020	365	393	41	2,852	36	1
2021	356	377	40	2,919	37	1
2022	347	360	38	2,987	38	1
2023	337	342	36	3,056	39	1
2024	327	322	34	3,127	39	1
2025	315	302	33	3,200	40	1
2026	322	295	32	3,274	41	1
2027	330	288	32	3,351	42	1
2028	337	280	31	3,429	43	1
2029	345	272	31	3,509	44	1
2030	352	263	30	3,590	45	1
2031	359	265	30	3,674	46	1
2032	366	267	31	3,759	47	1
2033	373	268	31	3,847	49	1
2034	380	270	31	3,936	50	1
2035	388	272	31	4,028	51	1
2036	395	274	32	4,122	52	1
2037	403	275	32	4,218	53	1
2038	410	277	32	4,316	55	1
2039	418	278	33	4,417	56	1
2040	426	280	33	4,519	57	1
2041	434	281	33	4,625	58	1
2042	443	282	34	4,732	60	1
2043	451	283	34	4,842	61	1
2044	460	284	34	4,955	63	1
2045	468	285	34	5,071	64	1
2046	477	286	35	5,189	66	1
2047	486	287	35	5,309	67	1
2048	495	287	35	5,433	69	1
2049	505	288	35	5,559	70	1
2050	514	288	36	5,689	72	1



Table 11.5: Capital and O&M Costs for Resource Options (Paired Grid-Scale Storage (2hrs), Paired Grid-Scale Storage (4hrs))

Year	Paired Grid-Scale Storage (2hr)		Paired Grid-Scale Storage (4hr)	
	Capital (\$/kW)	O&M (\$/kW-year)	Capital (\$/kW)	O&M (\$/kW-year)
2020	858	41	1,444	41
2021	827	40	1,389	40
2022	795	38	1,331	38
2023	802	36	1,339	36
2024	810	34	1,394	34
2025	753	33	1,301	33
2026	737	32	1,272	32
2027	722	32	1,182	32
2028	716	31	1,162	31
2029	708	31	1,141	31
2030	700	30	1,119	30
2031	709	30	1,131	30
2032	717	31	1,142	31
2033	726	31	1,154	31
2034	734	31	1,166	31
2035	743	31	1,177	31
2036	752	32	1,188	32
2037	760	32	1,200	32
2038	769	32	1,211	32
2039	778	33	1,222	33
2040	786	33	1,232	33
2041	795	33	1,243	33
2042	803	34	1,258	34
2043	812	34	1,272	34
2044	820	34	1,287	34
2045	829	34	1,301	34
2046	837	35	1,315	35
2047	846	35	1,328	35
2048	854	35	1,342	35
2049	862	35	1,355	35
2050	870	36	1,367	36





Table 11.6: Capital and O&M Costs for Resource Options (Paired Grid-Scale Storage (6hrs), Paired Grid-Scale Storage (8hrs), DER Aggregator)

Year	Paired Grid-Scale Storage (6hr)		Paired Grid-Scale Storage (8hr)		DER Aggregator – PV+Storage	
	Capital (\$/kW)	O&M (\$/kW-year)	Capital (\$/kW)	O&M (\$/kW-year)	Capital (\$/kW)	O&M (\$/kW-year)
2020	2,030	41	2,616	41	5,836	82
2021	1,951	40	2,513	40	5,578	79
2022	1,868	38	2,404	38	5,303	76
2023	1,875	36	2,412	36	5,354	73
2024	1,979	34	2,564	34	6,843	69
2025	1,849	33	2,397	33	6,480	66
2026	1,808	32	2,343	32	6,162	64
2027	1,693	32	2,215	32	5,968	61
2028	1,648	31	2,156	31	5,652	59
2029	1,600	31	2,092	31	5,320	56
2030	1,549	30	2,025	30	4,976	53
2031	1,568	30	2,048	30	5,032	54
2032	1,588	31	2,071	31	5,087	55
2033	1,607	31	2,093	31	5,143	56
2034	1,626	31	2,116	31	5,198	56
2035	1,645	31	2,138	31	5,253	57
2036	1,663	32	2,160	32	5,307	58
2037	1,682	32	2,181	32	5,362	58
2038	1,700	32	2,202	32	5,416	59
2039	1,718	33	2,222	33	5,470	60
2040	1,735	33	2,243	33	5,523	60
2041	1,753	33	2,262	33	5,576	61
2042	1,770	34	2,281	34	5,628	62
2043	1,786	34	2,300	34	5,680	62
2044	1,802	34	2,318	34	5,731	63
2045	1,818	34	2,336	34	5,781	64
2046	1,834	35	2,352	35	5,830	65
2047	1,848	35	2,368	35	5,879	65
2048	1,863	35	2,384	35	5,927	66
2049	1,876	35	2,398	35	5,974	67
2050	1,890	36	2,412	36	6,020	67



Table 11.7: Capital and O&M Costs for Resource Options (Synchronous Condenser, Geothermal, Municipal Solid Waste)

Year	Synchronous Condenser	Geothermal		Municipal Solid Waste (MSW)		
	Capital (\$/kVar)	Capital (\$/kW)	O&M (\$/kW-year)	Capital (\$/kW)	O&M (\$/kW-year)	Var O&M (\$/MWH)
2020	1,255	8,869	219	1,870	24	7
2021	1,272	8,989	223	1,908	24	8
2022	1,296	9,109	226	1,946	25	8
2023	1,299	9,230	230	1,979	26	8
2024	1,314	9,352	234	2,023	26	8
2025	1,340	9,475	238	2,071	27	8
2026	1,361	9,598	242	2,108	27	8
2027	1,372	9,722	246	2,146	28	9
2028	1,393	9,847	250	2,184	29	9
2029	1,416	9,972	254	2,222	29	9
2030	1,442	10,097	258	2,259	30	9
2031	1,470	10,281	264	2,298	31	10
2032	1,494	10,467	270	2,334	32	10
2033	1,519	10,658	276	2,368	32	10
2034	1,546	10,851	283	2,407	33	10
2035	1,574	11,048	290	2,446	34	10
2036	1,600	11,249	296	2,484	35	11
2037	1,628	11,453	303	2,523	35	11
2038	1,657	11,661	310	2,564	36	11
2039	1,689	11,873	317	2,607	37	11
2040	1,716	12,089	325	2,648	38	12
2041	1,747	12,309	332	2,688	39	12
2042	1,777	12,532	340	2,731	40	12
2043	1,809	12,760	348	2,776	41	13
2044	1,841	12,992	356	2,821	42	13
2045	1,875	13,228	364	2,869	43	13
2046	1,908	13,468	373	2,914	44	13
2047	1,942	13,712	382	2,959	45	14
2048	1,976	13,962	390	3,003	46	14
2049	2,007	14,215	400	3,049	47	14
2050	2,030	14,473	409	3,065	48	15



Table 11.8: Capital and O&M Costs for Resource Options (Biomass)

Year	Biomass			
	Capital (\$/kW)	O&M (\$/kW-year)	Var O&M (\$/MWH)	Fuel Cost (\$/MWH)
2020	5,985	182	6	4
2021	6,106	186	6	4
2022	6,228	190	6	4
2023	6,331	195	6	4
2024	6,475	199	6	4
2025	6,626	204	7	4
2026	6,745	209	7	4
2027	6,868	213	7	5
2028	6,990	218	7	5
2029	7,111	224	7	5
2030	7,227	229	7	5
2031	7,353	234	7	5
2032	7,468	239	8	5
2033	7,579	245	8	5
2034	7,703	251	8	5
2035	7,827	257	8	5
2036	7,948	263	8	6
2037	8,075	269	9	6
2038	8,206	275	9	6
2039	8,342	281	9	6
2040	8,474	288	9	6
2041	8,602	295	9	6
2042	8,741	301	10	6
2043	8,883	308	10	7
2044	9,027	316	10	7
2045	9,180	323	10	7
2046	9,326	331	11	7
2047	9,468	338	11	7
2048	9,610	346	11	7
2049	9,757	354	11	8
2050	9,808	362	12	8



Table 11.9: Capital and O&M Costs for Resource Options (Concentrated Solar, Combined Cycle)

Year	Concentrated Solar			Combined Cycle		
	Capital (\$/kW)	O&M (\$/kW-year)	Var O&M (\$/MWH)	Capital (\$/kW)	O&M (\$/kW-year)	Var O&M (\$/MWH)
2020	7,425	80	4	1,420	33	2
2021	7,284	81	4	1,445	34	2
2022	7,105	81	4	1,476	35	2
2023	7,344	81	4	1,493	35	2
2024	8,366	81	4	1,521	36	2
2025	8,231	80	4	1,557	37	2
2026	8,124	80	4	1,586	38	2
2027	8,044	79	4	1,609	39	2
2028	7,992	78	4	1,639	40	3
2029	7,968	78	4	1,670	41	3
2030	7,971	77	4	1,702	42	3
2031	8,000	79	5	1,735	43	3
2032	8,056	81	5	1,768	44	3
2033	8,137	83	5	1,797	45	3
2034	8,243	84	5	1,833	46	3
2035	8,372	86	5	1,867	47	3
2036	8,524	88	5	1,900	48	3
2037	8,697	90	5	1,935	49	3
2038	8,889	93	5	1,974	50	3
2039	9,099	95	5	2,010	51	3
2040	9,313	97	6	2,048	52	3
2041	9,532	99	6	2,086	54	3
2042	9,757	101	6	2,125	55	4
2043	9,986	104	6	2,166	56	4
2044	10,221	106	6	2,207	58	4
2045	10,461	109	6	2,250	59	4
2046	10,706	111	6	2,294	60	4
2047	10,957	114	7	2,337	62	4
2048	11,214	117	7	2,377	63	4
2049	11,476	119	7	2,421	65	4
2050	11,744	122	7	2,448	66	4



Table 11.10: Capital and O&M Costs for Resource Options (Combustion Turbine, Internal Combustion Engine)

Year	Combustion Turbine			Internal Combustion Engine		
	Capital (\$/kW)	O&M (\$/kW-year)	Var O&M (\$/MWH)	Capital (\$/kW)	O&M (\$/kW-year)	Var O&M (\$/MWH)
2020	1,255	25	6	2,648	37	28
2021	1,272	26	6	2,684	38	29
2022	1,296	27	6	2,734	39	29
2023	1,299	27	6	2,740	40	30
2024	1,314	28	7	2,773	41	31
2025	1,340	28	7	2,827	42	31
2026	1,361	29	7	2,872	43	32
2027	1,372	30	7	2,894	44	33
2028	1,393	30	7	2,939	45	34
2029	1,416	31	7	2,988	46	34
2030	1,442	32	8	3,042	47	35
2031	1,470	33	8	3,101	48	36
2032	1,494	33	8	3,153	49	37
2033	1,519	34	8	3,205	50	38
2034	1,546	35	8	3,262	51	39
2035	1,574	36	8	3,320	53	40
2036	1,600	37	9	3,375	54	40
2037	1,628	37	9	3,435	55	41
2038	1,657	38	9	3,496	56	42
2039	1,689	39	9	3,563	58	43
2040	1,716	40	9	3,621	59	44
2041	1,747	41	10	3,685	60	45
2042	1,777	42	10	3,750	62	46
2043	1,809	43	10	3,816	63	48
2044	1,841	44	10	3,883	65	49
2045	1,875	45	11	3,957	66	50
2046	1,908	46	11	4,026	68	51
2047	1,942	47	11	4,097	69	52
2048	1,976	48	11	4,168	71	53
2049	2,007	49	12	4,235	73	55
2050	2,030	51	12	4,284	74	56



# Appendix B: Distributed Energy Resource Forecasts (2020 – 2050)

Table 11.11: Cumulative Distributed PV Capacity (kW)

Year	O’ahu	Hawai’i Island	Maui	Moloka’i	Lāna’i	Consolidated
MW	A	B	C	D	E	F =A + B + C + D +E
2020	534,704	110,108	119,232	2,678	832.72	767,555
2021	578,150	118,086	129,449	2,836	868.72	829,389
2022	644,017	124,018	138,586	2,936	900.72	910,458
2023	681,381	130,519	147,329	3,100	1005.72	963,335
2024	701,907	134,421	152,758	3,152	1025.72	993,264
2025	723,234	138,801	158,260	3,200	1,050	1,024,545
2026	744,949	143,671	163,786	3,268	1,091	1,056,764
2027	766,577	148,742	169,165	3,400	1,179	1,089,063
2028	788,306	153,820	174,641	3,476	1,211	1,121,454
2029	809,690	159,053	180,120	3,548	1,260	1,153,671
2030	830,974	164,392	185,501	3,696	1,356	1,185,919
2031	851,110	169,563	190,787	3,776	1,405	1,216,641
2032	870,093	174,395	195,679	3,856	1,437	1,245,460
2033	887,886	179,126	200,340	3,928	1,469	1,272,749
2034	905,021	183,812	204,847	4,060	1,574	1,299,314
2035	921,457	188,390	209,200	4,116	1,602	1,324,765
2036	936,961	192,830	213,399	4,180	1,630	1,349,000
2037	951,843	197,150	217,465	4,244	1,731	1,372,433
2038	966,214	201,392	221,405	4,292	1,759	1,395,062
2039	980,005	205,496	224,746	4,416	1,787	1,416,450
2040	993,411	209,179	227,968	4,476	1,888	1,436,922
2041	1,006,467	213,179	231,325	4,520	1,916	1,457,407
2042	1,019,145	216,764	234,337	4,576	1,940	1,476,762
2043	1,031,362	220,530	237,470	4,616	1,964	1,495,942
2044	1,042,809	224,193	240,272	4,732	2,001	1,514,007
2045	1,053,934	227,449	242,917	4,768	2,085	1,531,153
2046	1,064,689	230,902	245,471	4,816	2,109	1,547,987
2047	1,075,171	233,953	248,174	4,848	2,146	1,564,292
2048	1,085,318	237,208	250,560	4,892	2,166	1,580,144



Year	O'ahu	Hawai'i Island	Maui	Moloka'i	Lāna'i	Consolidated
MW	A	B	C	D	E	F = A + B + C + D + E
2049	1,095,227	240,131	253,102	4,924	2,186	1,595,570
2050	1,104,843	243,258	255,327	4,952	2,266	1,610,646



Table 11.12: Cumulative Distributed BESS Capacity (kWh)

Year	O'ahu	Hawai'i Island	Maui	Moloka'i	Lāna'i	Consolidated
MW	A	B	C	D	E	F = A + B + C + D + E
2020	54,034	37,313	41,409	173	114.05	133,043
2021	99,912	50,066	65,335	443	251.3	216,007
2022	179,528	55,880	89,495	819.5	343.55	326,067
2023	252,823	70,465	107,323	1083.5	415.55	432,111
2024	284,230	76,961	117,759	1203.5	460.55	480,615
2025	317,754	84,230	128,263	1347.5	514.55	532,110
2026	352,482	92,294	138,731	1515.5	577.55	585,601
2027	387,489	100,626	148,874	1,684	640.55	639,314
2028	423,066	108,969	159,054	1,876	712.55	693,677
2029	458,478	117,597	169,152	2,092	793.55	748,112
2030	493,412	126,316	179,030	2,308	874.55	801,941
2031	526,663	134,728	188,609	2,512	955.55	853,467
2032	557,885	142,412	197,427	2,716	1027.55	901,468
2033	587,332	149,910	205,740	2,896	1099.55	946,977
2034	615,321	157,223	213,711	3,064	1171.55	990,491
2035	641,891	164,338	221,342	3,232	1234.55	1,032,037
2036	667,128	171,200	228,634	3,388	1297.55	1,071,648
2037	691,116	177,842	235,632	3,544	1360.55	1,109,495
2038	713,973	184,341	242,351	3,688	1423.55	1,145,776
2039	735,673	190,587	248,779	3,832	1,487	1,180,357
2040	756,521	196,611	254,943	3,976	1,550	1,213,601
2041	776,594	202,563	260,890	4,108	1,613	1,245,767
2042	795,830	208,305	266,589	4,240	1,667	1,276,631
2043	814,174	213,828	272,043	4,360	1,721	1,306,125
2044	831,671	219,163	277,280	4,480	1,775	1,334,369
2045	848,456	224,301	282,258	4,588	1,829	1,361,431
2046	864,549	229,250	287,034	4,696	1,883	1,387,412
2047	880,038	234,012	291,625	4,792	1,937	1,412,403
2048	894,914	238,598	296,032	4,888	1,982	1,436,413
2049	909,265	243,023	299,549	4,984	2,027	1,458,848
2050	923,096	247,272	303,603	5,068	2,072	1,481,111





# Appendix C: Forecast Methodologies

## 1. UNDERLYING FORECAST METHODOLOGIES

The sales forecasts were developed for each of the five islands and began with the development of the sales forecast by rate class (residential, commercial and street lighting) and by layer (underlying load forecast and adjusting layers – energy efficiency, distributed energy resources, and electrification of transportation). Key factors that affect sales in the future are identified such as the economic outlook, analysis of existing and proposed large customer loads, and impacts of customer-sited technologies such as energy efficiency measures, distributed energy resources and emerging technologies such as electric vehicles. This section focuses on the development of the underlying sales forecast which excludes impacts from previously installed and future DER, EE and EVs.

Multiple methods and models were analyzed to develop the underlying forecast as one model does not fit all. The methods are described below and were presented in the July 17, 2019 FAWG meeting, slides 10-12<sup>98</sup>. More than one model or method may be used to blend together a short term forecast with a long term forecast. Methods for the underlying layer include:

- Market analysis - a ground up forecast evaluating individual customers, particularly large commercial customers, forecasting individual projects or awareness of events that may merit a specific carve out if significant, i.e. new large projects or loss of large loads.
- Customer service - analysis of recent trends in customer counts, sales and use per customer and applies knowledge of local conditions such as construction activity, state of the visitor industry, trends in weather including impacts of storms and volcanic eruptions.
- Trending models – uses historical data series to project future sales or customer counts. Works well when historical data series has identifiable patterns and future trends aren't expected to vary from the past.
- Econometric models – relates sales or customers' use of electricity to macroeconomic variables such as personal income, jobs, population and visitor arrivals as well as other variables such as temperature, humidity or electricity price. Econometric models may also incorporate time series parameters such as lagged dependent variables or an autoregressive term. The quantification of the impact of changes in the economic and other variables on use is the strength of these models. The econometric model is specified in the following form:

<sup>98</sup> Available at, [https://www.hawaiianelectric.com/documents/clean\\_energy\\_hawaii/integrated\\_grid\\_planning/stakeholder\\_engagement/working\\_groups/forecast\\_assumptions/20190717\\_wg\\_fa\\_meeting\\_presentation\\_materials.pdf](https://www.hawaiianelectric.com/documents/clean_energy_hawaii/integrated_grid_planning/stakeholder_engagement/working_groups/forecast_assumptions/20190717_wg_fa_meeting_presentation_materials.pdf)



$$Y = \beta_0 + \sum_{i=1}^n (\beta_i x X_i)$$

where the dependent variable,  $Y$ , is kWh sales or use per customer and is related to the independent (explanatory) variables,  $X_i$ , which represent economic or other variables. Variables  $\beta_i$  represent the regression model coefficients. The constant variable  $\beta_0$  represents the Y-intercept.

Various models are evaluated for best fit and explanatory power however, it is important to assess if the models make sense. Is it reasonable to believe that electricity sales are related to the external variables in the model? Is the direction of the relationship plausible?

A description of the assumptions and models used to develop the underlying forecasts presented at the March 3, 2020 FAWG meeting and described in the response to PUC-HECO-IR-1<sup>99</sup> by rate class for O‘ahu, Hawai‘i, Maui, Moloka‘i and Lāna‘i are provided below under each island’s section.

Leading up to the March 3<sup>rd</sup> FAWG meeting, local economists were describing Hawai‘i’s economy as being on an expected slowing trend for the past several years even prior to the spread of the coronavirus (“COVID-19”). Immediately following the March 3<sup>rd</sup> meeting economic scenarios about the impact of COVID-19 were being developed with very limited information. The COVID-19 pandemic resulted in unprecedented disruptions to global travel, local resident behavior, economic activity and as a result, electricity consumption. State and county emergency orders beginning with stay-at-home orders and mandatory post-arrival travel quarantines in March 2020 basically shutdown the Hawai‘i economy, especially the tourism industry. Electricity usage was severely impacted, although in different ways depending on the sector. Several economic updates were issued in the following months by the University of Hawai‘i Economic Research Organization (“UHERO”), with the outlook rapidly changing as new emergency orders went into effect.

The Company’s updated forecast was informed by multiple types of data to provide numerous sources of insight into this unprecedented time. Customer information was analyzed including available customer-level consumption data from before and after the governments’ emergency orders went into effect, customers’ public announcements regarding closures and reopening plans, feedback from customers to their Hawaiian Electric account managers, distribution circuit data from before and after emergency orders went into effect, and customer billing data. Local economists, organizations and businesses in Hawai‘i discussed impacts to the local economy and their perspectives on recovery in multiple public forums. Information from other utilities on Covid-19 related impacts

<sup>99</sup> Available at,

[https://www.hawaiianelectric.com/documents/clean\\_energy\\_hawaii/integrated\\_grid\\_planning/stakeholder\\_engagement/working\\_groups/forecast\\_assumptions/dkt\\_20180165\\_20200702\\_HECO\\_response\\_to\\_PUC\\_IRs\\_1-2.pdf](https://www.hawaiianelectric.com/documents/clean_energy_hawaii/integrated_grid_planning/stakeholder_engagement/working_groups/forecast_assumptions/dkt_20180165_20200702_HECO_response_to_PUC_IRs_1-2.pdf)



to electricity consumption and methods for projecting recovery was also considered. The Company updated its underlying forecasts to account for the impacts of COVID-19 and anticipated recovery as presented in the August 31, 2020 FAWG meeting<sup>100</sup> and are also described for each island below.

## O‘ahu Underlying Forecast

Econometric methods were used for deriving the underlying sales for both the residential and commercial sectors. Historical recorded sales used in econometric models were adjusted to remove sales impact of DER, EE and EoT, which are treated as separate layers.

### Residential Sales

The residential econometric equation was specified using a monthly use per residential customer in kilowatt-hours (“kWh”). The monthly econometric model describes residential electricity use per customer as a function of temperature, humidity, electricity price and real personal income per capita as these variables were all found to have relationships with residential use per customer. In addition, a simple trend variable and a monthly dummy variable were included in the models. The trend variable which increases by 1 was used as a proxy for growth and the binary dummy variable representing January or August (1 if January or August; 0 otherwise) improves the model statistics. Additional details on each variable, dependent and independent, used in deriving the monthly use per residential customer including the name of the variable and the source of the information are shown below. The values of the variables fed into the econometric modeling tool and the output from the model are contained in the Excel file “Appendix C Att 1 HE Underlying Inputs and Predicted.xlsx”.<sup>101</sup>

The specification and evaluation of the hypothetical relationships was performed using a proprietary software package, MetrixND from Itron, Inc. MetrixND is a statistical analysis package which allows Hawaiian Electric to conduct analyses and statistical testing of econometric models. Many hypothetical relationships were considered, tested, and rejected until econometric equations for residential use per customer and commercial kWh sales were identified for use in Hawaiian Electric’s sales projections.

---

<sup>100</sup> Available at, [https://www.hawaiianelectric.com/documents/clean\\_energy\\_hawaii/integrated\\_grid\\_planning/stakeholder\\_engagement/working\\_groups/forecast\\_assumptions/20200831\\_wg\\_fa\\_meeting\\_presentation\\_materials\\_HECO.pdf](https://www.hawaiianelectric.com/documents/clean_energy_hawaii/integrated_grid_planning/stakeholder_engagement/working_groups/forecast_assumptions/20200831_wg_fa_meeting_presentation_materials_HECO.pdf)

<sup>101</sup> See <https://www.hawaiianelectric.com/clean-energy-hawaii/integrated-grid-planning/stakeholder-engagement/working-groups/forecast-assumptions-documents>



Table 11.13: O’ahu Residential Customer Econometric Sales Model Variables

Variables	Description	Source	Variable Labels
<i>Dependent Variable:</i>			
Monthly Residential Use Per Customer	Monthly residential recorded kWh sales divided by Monthly residential recorded customers	Hawaiian Electric’s monthly reports filed with the Commission	Res_rcd_adj divided by Res_Cust_rcd
<i>Weather Variables:</i>			
Cooling Degree Days	1999 – 2018 average + warming trend	Historical HNL airport data from NOAA, see FAWG presentation on August 27, 2019.	cdd_99_18add
Dewpoint Temperature	1999 – 2018 average	Historical HNL airport data from NOAA	dewpt_99_18
<i>Economic Variables:</i>			
Real Residential electricity price	Real Residential \$ (1982-84=100) per kWh	See FAWG presentation on August 27, 2019	Res_rprc_rcd
Real personal income per capita	Real personal income (1982-84=100) ÷ Resident population	UHERO updated forecast dated October 2019	ypc_r_hon = y_r_hon ÷ respop_hon
<i>Trend &amp; Dummy Variables:</i>			
Trend variable	Growth proxy	Trend variable that increases by 1 per month	mo_yr_time
Monthly dummy variables	January and August	Improves model statistics	m_1 and m_8



To arrive at sales per month, the monthly use per residential customer derived in MetrixND was multiplied by the number of residential customers. The number of customers per month was derived using a linear trend time series model based on historical residential customer data from January 1980 through December 2018. The trending model used the maximum data points available to incorporate historical trends since residential customer growth is relatively stable.

The resulting residential GWh underlying sales forecast is residential kWh use per customer  $\div 10^6 \times$  number of customers ( $\text{Res\_rcd\_adj} \div 10^6 \times \text{Res\_Cust\_rcd}$ ). An adjustment was made to include an extra day for leap year.

Commercial Sales

The econometric model used for underlying commercial sales was run for the combined rate schedules applied to small, medium and large commercial customers excluding street lighting rather than for individual rate schedules (Schedules G, J, P, DS and U) as it had stronger explanatory relationships since O’ahu commercial customers historically tend to transfer between commercial rate schedules on a regular basis (based on tariff requirements). The underlying commercial sales econometric equation was specified using monthly sales in kilowatt-hours. The monthly econometric model describes electricity sales as a function of temperature, humidity, electricity price and non-agricultural jobs as these variables were all found to have relationships with commercial sales. In addition, monthly binary dummy variables representing February, August or October (1 if February, August or October; 0 otherwise) and another dummy variable for months starting from January 2015 and onwards which reflect a change in the relationship between non-agricultural jobs and sales improve the model statistics. Additional details on each variable, dependent and independent, used in deriving the monthly sales including the name of the variable and the source of the information are shown below. The values of the variables fed into the econometric modeling tool (independent variables) and the output from the model are contained in the Excel file “Appendix C Att 1 HE Underlying Inputs and Predicted.xlsx”.<sup>102</sup>

Table 11.14: O’ahu Commercial Customer Econometric Sales Model Variables

Variable	Description	Source	Variable Labels
<i>Dependent Variable:</i>			
Commercial Sales	Commercial recorded kWh sales (1984 - 2018)	Hawaiian Electric’s monthly reports filed with the Commission	Com_rcd_adj

<sup>102</sup> See <https://www.hawaiianelectric.com/clean-energy-hawaii/integrated-grid-planning/stakeholder-engagement/working-groups/forecast-assumptions-documents>



<i>Weather Variables:</i>			
Cooling Degree Days	1999 – 2018 average + warming trend	Historical HNL airport data from NOAA see FAWG presentation on August 27, 2019	cdd_99_18add
Dewpoint Temperature	1999 – 2018 average	Historical HNL airport data from NOAA	dewpt_99_18
<i>Economic Variables:</i>			
Real commercial electricity price	Real commercial \$ (1982-84=100) per kWh	See FAWG presentation on August 27, 2019	Com_rprc_rcd
Non-Ag Jobs	Non-agricultural job counts	UHERO, October 2019	E_NF_Hon
<i>Trend Variable:</i>			
Trend variable	Growth proxy	Trend variable that increases by 1 per month	mo_yr_time
Monthly dummy variables	February, August, and October	Improves model statistics	m_2, m_8, m_10
Dummy variable	For all months starting in January 2015 and continuing through December 2050	Relationship between non-ag jobs and commercial kWh appeared to change beginning in 2015, addition of this variable improved model statistics.	d_15on

The resulting commercial GWh sales forecast is commercial kWh underlying sales forecast ÷ 10<sup>6</sup>. (Com\_rcd\_adj ÷ 10<sup>6</sup>). Adjustments were made to include an extra day for leap year and for known large projects.

Street Lighting Sales



Sales for street lighting are less sensitive to changes in economic and weather drivers than sales in other rate schedules and represent less than 0.5% of Hawaiian Electric’s sales. Consequently, an econometric or modeled approach to forecasting Schedule F sales was not developed. The average 2013 – 2018 growth rate in the underlying Schedule F kWh sales (excluding EE impacts) was applied as year-over-year growth for the forecast horizon. Additional growth was included for new unmetered pole attachments (e.g., third party telecom and network devices) based on market projections for number of attachments and existing attachments’ kWh use.

The resulting street lighting GWh sales forecast is the underlying street lighting commercial kWh underlying sales forecast  $\div 10^6$  ( $f\_rcd\_adj \div 10^6$ ). An adjustment was made to include an extra day for leap year.

The values of the underlying street lighting in kWh are contained in the Excel file “Appendix C Att 1 HE Underlying Inputs and Predicted.xlsx”.<sup>103</sup>

#### COVID-19 Update to the Underlying Sales for O’ahu

O’ahu’s stay-at-home orders went into effect on March 23, 2020. Under Mayor Caldwell’s Emergency Order No. 2020-02, “All persons may leave their residences only for Essential Activities, Essential Governmental Functions, or to operate Essential Businesses...” This order basically shutdown the O’ahu economy, especially the tourism industry. This unprecedented shutdown was a shock to Hawai’i’s economy that has never been experienced before. Electricity usage was severely impacted, although in different ways depending on the sector. The economic impact and uncertainty about the length of the shutdown added to the confusion. Several economic updates were issued in the following month or two by UHERO, rapidly changing as new emergency orders went into effect.

Hawaiian Electric’s econometric models were unable to incorporate the changes in the economic outlook because there had never been a period in history that could establish what the relationship between the economic shock and electricity use might be. Stay-at home orders basically shutdown hotels, office buildings, schools, retail and other building types where occupants could work from home or were not providing an essential service (including restaurants, bars, movie theaters, and most small businesses). On the other hand, residential usage increased as people were forced to stay home 24 hours a day.

The economic information and updates were rapidly changing and did not have as much detail as would normally be used in the sales forecast, in addition, customer behavior changed immediately and drastically in response to emergency orders and fears of the new unknown virus. As a result, a sales forecast update for the very near-term (2020 – 2021) was developed using more judgmental techniques

<sup>103</sup> See <https://www.hawaiianelectric.com/clean-energy-hawaii/integrated-grid-planning/stakeholder-engagement/working-groups/forecast-assumptions-documents>



to update the very near-term forecast, then blended with more traditional econometric models using updated economic outlooks (covering 2 – 5 years) as they became available.

For the very near-term forecast, current to 18 months ahead, the O‘ahu forecast was developed by analyzing very limited data for specific customers in Itron Inc.’s MV-Web billing system. Using available customer data for before and after the shutdown orders went into effect (only 3 – 4 weeks of post COVID data was available when the analysis was done), an estimate of the immediate impact (percentage change) was developed to use as a proxy for the commercial sectors by business types (e.g., hotel, office, retail, education). UHERO updates were used to estimate the length of time the lowest economic activity would continue and the how long it would take to see some recovery.

The residential sector was even more difficult to estimate because meter reads were stopped due to safety concerns for customers and meter readers. Residential customers’ bills were estimated from late March until mid-May 2020 using previous consumption patterns which were low relative to stay-at-home COVID usage. There was no billing data beyond anecdotal stories about how residential usage was affected by the stay-at-home orders. The Distribution Planning Department assisted in obtaining real time circuit level energy data from the Company’s PI system for specific residential areas. This data was used to derive a high-level impact factor to apply to total residential sales.

Information on data and trends in other jurisdictions were obtained from webinars, meetings, blogs, email blasts, and publications, primarily from EEI and other utilities. This information was used to help validate the projections the Company was developing for O‘ahu. Of particular interest were the trends from other utilities that had more granular data from widely deployed AMI meters. UHERO, DBEDT, and other economists discussed the local economy in multiple meetings with the State Legislature, business groups, and in the news which provided rapidly changing outlooks that influenced forecast assumptions.

In the longer run (2 – 5) years, UHERO provided an April 2020 economic outlook that was used to develop econometric models for the commercial sectors. The econometric relationship for the residential sector remained undeterminable, so a year-over-year percentage growth from the IGP forecast was used. After 5 years, the impact of the COVID pandemic had dissipated (assuming a vaccine was developed) and the more normal economic trends resumed. As a result, the IGP forecast was used for the long-term.

### **Hawai‘i Underlying Forecast**

For Hawai‘i Island the underlying forecast is developed by rate class - residential, small and medium commercial, large power and street lighting. Similar to O‘ahu, historical recorded sales used in the models were adjusted to remove sales impact of DER, EE and EoT.





## Residential Sales

The residential underlying sales forecast is developed using a combination of two forecast methods, the customer service method in the near term (2019-2020) and then an econometric model for the remainder of the forecast period. The customer service method allows for factors including knowledge of local economic conditions such as construction activity, the state of the visitor industry and a review of weather conditions as well as other island specific circumstances such as the volcano eruption on Hawai'i Island in 2018 to be considered in the analysis. At the time the underlying forecast was developed, actual Schedule R data was available through October 2019, which was used to inform the forecasts for 2019 and 2020.

The customer service method for residential sales examines historical and recent trends in customer count growth and underlying average use (kWh sales) per customer. In forecasting 2019 and 2020, this analysis also needed to take into consideration the residential customer losses that occurred in 2018 when homes were destroyed by the volcano eruption. October 2019 year-to-date year-over-year growth in customer count excluding eruption losses was used as the basis for projecting 2019 and 2020 residential customers. Similarly, careful analysis of underlying average use through October 2019 looking at both year-to-date and recent monthly trends in year-over-year changes was undertaken. This analysis included factoring in unusual circumstances from 2018 such as eruption losses, impacts of transfers from Schedule G to Schedule R and poor air quality in the summer as a result of the eruption as well as weather impacts in 2019. Forecasted 2019 and 2020 underlying average use was forecasted taking these factors into consideration. The forecasted number of customers multiplied by the forecasted average use per customer results in the forecasted residential underlying sales for 2019 and 2020.

The residential econometric equation is specified using adjusted residential class sales per month in megawatt-hours (MWh). The adjusted sales are the monthly residential MWh sales excluding the historical estimated impacts from each of the layers (DER, EE and EV) to result in underlying residential sales. This also includes impacts from significant transfers between rate classes, to reflect the accounts currently in the rate class.

The monthly econometric model describes residential electricity sales as a function of resident population, real personal income per capita, monthly visitor arrivals to the County, electricity price and weather variables (temperature humidity index and precipitation). In recognition of the climate differences between the Hilo and Kona sides of the island, the Hilo and Kona weather data is weighted based on historical sales by region and weighted weather variables are utilized in the model. For the forecast years, the weighting is a five-year historical average (2014-2018). These variables were all found to have relationships with residential sales. In addition, three sets of binary dummy variables were created – 1) monthly dummy variables representing individual months of the year, excluding February, used to account for seasonal variations, 2) a dummy variable



to account for the significant amount of air conditioner installs starting in June 2015 and 3) a monthly dummy variable from October 2017 onwards in recognition of the policy change in the timing of transferring customers from a temporary service under commercial rate Schedule G to the residential rate Schedule R.

The specification and evaluation of the hypothetical relationships was performed using a proprietary software package, MetrixND from Itron, Inc. Many hypothetical relationships were considered, tested, and rejected until econometric equations for residential use per customer and commercial kWh sales were identified for use in Hawaiian Electric’s sales projections.

Additional details on each variable, dependent and independent, used in deriving the monthly residential customer sales including the name of the variable and the source of the information are shown below. The values of the variables fed into the econometric modeling tool and the output from the model are contained in the Excel file “Appendix C Att 2 HL Underlying Inputs and Predicted.xlsx”.<sup>104</sup>

Table 11.15: Hawai’i Residential Econometric Sales Model Variables

Variable	Description	Source	Variable Labels
<i>Dependent Variable:</i>			
Residential Sales	Adjusted Schedule R Sales (MWh)	Hawaiian Electric’s monthly reports filed with the Commission	Adjusted R Sales (MWh)
<i>Economic Variables:</i>			
Monthly Resident Population	Resident Population, Hawai’i County. Allocated to monthly values using straight-line approach with annual values assumed to be in July of each year	UHERO, October 2019	Monthly Resident Population
Real Annual Income Per Capita	Real Personal Income (1982-84 = 100) ÷ Resident Population (Hawai’i County)	UHERO, October 2019	Annual Income Per Capita (\$82-84)

<sup>104</sup> <https://www.hawaiielectric.com/clean-energy-hawaii/integrated-grid-planning/stakeholder-engagement/working-groups/forecast-assumptions-documents>



Monthly Visitor Arrivals	Visitor Arrivals (Hawai'i County), allocated to monthly values using historical patterns	UHERO, October 2019	Monthly Visitor Arrivals
Real Monthly Residential Electricity Price, one-month lag	Real residential dollars per kwh (1982-84=100) (Hawai'i Island)	see FAWG presentation on August 27, 2019	R Electricity Price (\$82-84) (1-month lag)
<i>Weather Variables:</i>			
Monthly Weighted THI (temperature humidity index)	<p>Composite weather variable to incorporate both temperature and humidity.</p> <p>Wtd THI = 17.5 + (0.55 * Wtd Avg Temperature) + (0.20 * Wtd Dewpoint)</p> <p>Forecast uses 20-year average (1999-2018) of weighted average temperature and weighted dewpoint to calculate THI. Warming trend included in forecasted average temperatures.</p>	Historical airport weather data (Hilo and Kona) from NOAA	Weighted THI
Monthly Weighted Precipitation	Rainfall in inches	Historical airport weather data (Hilo and Kona) from NOAA	Weighted Precipitation



<i>Dummy Variables:</i>			
Monthly dummy variables	Dummy variable for each individual month to account for seasonal variation, excluding February	Improves model statistics	Dmy Jan, Dmy Mar...Dmy Dec
Dummy variable starting in June 2015	Proxy for impacts of increased a/c installs	Improves model statistics	Dmy 615-on
Dummy variable for Schedule G to Schedule R transfers	October 2017-on, proxy for policy change for transfer of temporary Schedule G (construction accounts) to Schedule R	The historical sales data series was adjusted for known transfers, but the dummy variable reflects the change in the transfer process and picks up additional effects	Dmy GtoR TFR

The resulting monthly sales from the econometric model are then summed to annual sales forecast values. The year-over-year growth rates from the annual sales are then applied to the 2020 customer service forecast to extend the forecast out to the full 30-year range. Adjustments are made to include an extra day in leap years.

Small and Medium Commercial Sales (Rate Schedules G and J)

The small/medium commercial underlying sales forecast is developed using a combination of two forecast methods, the customer service method in the near term (2019-2020) and then applying year over year growth rates from an econometric model for the remainder of the forecast period. The customer service method allows for factors including knowledge of local economic conditions such as construction activity, the state of the visitor industry and a review of weather conditions as well as other island specific circumstances such as the volcano eruption on Hawai'i Island in 2018 to be considered in the analysis. At the time the underlying forecast was developed, actual Schedule G/J data was available through October 2019, which was used to inform the forecasts for 2019 and 2020.



The customer service method for small/medium commercial sales examines historical and recent trends in customer count growth and underlying average use (kWh sales) per customer similar to the approach for residential sales. In forecasting 2019 and 2020, this analysis also needed to take into consideration the small commercial customer account losses that occurred in 2018 as a result of the volcano eruption and account transfers from Schedule G to Schedule R. Careful analysis of both customer counts underlying average use through October 2019 examining both year-to-date and recent monthly trends in year-over-year changes was undertaken. Forecasted 2019 and 2020 underlying average use was forecasted taking these factors into consideration. The forecasted number of customers multiplied by the forecasted average use per customer results in the forecasted small/medium commercial underlying sales for 2019 and 2020.

The Schedule G/J econometric equation is specified using adjusted small/medium commercial class sales per month in megawatt-hours (MWh). The adjusted sales are the monthly Schedule G/J MWh sales excluding the historical estimated impacts from each of the layers (DER, EE and EV) to result in underlying Schedule G/J sales. This also includes impacts from significant transfers between rate classes, to reflect the accounts currently in the rate class.

The monthly econometric model describes Schedule G/J electricity sales as a function of resident population, real personal income per capita, monthly visitor arrivals to the County and weather variables (cooling degree days and precipitation). In recognition of the climate differences between the Hilo and Kona sides of the island, the Hilo and Kona weather data is weighted based on historical sales by region and weighted weather variables are utilized in the model. For the forecast years, the weighting is a five-year historical average (2014-2018). These variables were all found to have relationships with Schedule G/J sales. In addition, three sets of binary dummy variables were created – 1) monthly dummy variables representing individual months of the year, excluding February, used to account for seasonal variations, 2) a monthly dummy variable from September 2001 to September 2002 as a proxy for 9/11 impacts and 3) a dummy variable in February of leap years to account for leap day.

Additional details on each variable, dependent and independent, used in deriving the monthly small/medium commercial sales including the name of the variable and the source of the information are shown below. The values of the variables fed into the econometric modeling tool and the output from the model are contained in the Excel file “Appendix C Att 2 HL Underlying Inputs and Forecast.xlsx ”.<sup>105</sup>

Table 11.16: Hawai'i Small and Medium Commercial Customer Econometric Sales Model Variables

Variable	Description	Source	Variable Labels
<i>Dependent Variable:</i>			

<sup>105</sup> See <https://www.hawaiianelectric.com/clean-energy-hawaii/integrated-grid-planning/stakeholder-engagement/working-groups/forecast-assumptions-documents>



Small/Medium Commercial Sales	Adjusted Schedule G/J Sales (MWh)	Hawaiian Electric's monthly reports filed with the Commission	Adjusted GJ Sales (MWh)
<i>Economic Variables:</i>			
Monthly Resident Population	Resident Population, Hawai'i County. Allocated to monthly values using straight-line approach with annual values assumed to be in July of each year	UHERO, October 2019	Monthly Resident Population
Real Annual Income Per Capita	Real Personal Income (1982-84 = 100) ÷ Resident Population (Hawai'i County)	UHERO, October 2019	Annual Income Per Capita (\$82-84)
Monthly Visitor Arrivals	Visitor Arrivals (Hawai'i County), allocated to monthly values using historical patterns	UHERO, October 2019	Monthly Visitor Arrivals
<i>Weather Variables:</i>			
Monthly Weighted CDD (cooling degree days)	Cooling degree days (CDD) are the difference between the daily mean temperature (F) and 65 degrees, which are summed over the month.  Forecast uses 20-year average (1999-2018) of	Historical airport weather data (Hilo and Kona) from NOAA	Weighted CDD



	cooling degree days. Warming trend included in forecasted CDD.		
Monthly Weighted Precipitation, one-month lag	Rainfall in inches lagged by one month	Historical airport weather data (Hilo and Kona) from NOAA	Weighted Precipitation
<i>Dummy Variables:</i>			
Monthly dummy variables	Dummy variable for each individual month to account for seasonal variation, excluding February	Improves model statistics	Dmy Jan, Dmy Mar...Dmy Dec
Dummy variable September 2001 through September 2002	Proxy for 9/11 impacts	Improves model statistics	Dmy 9/11
Dummy variable for leap day	Dummy variable for February in leap years (historical only)	Improves model statistics	Dmy leap day

The resulting monthly sales from the econometric model are then summed to annual sales forecast values. The year-over-year growth rates from the annual sales are then applied to the 2020 customer service forecast to extend the forecast out to the full 30-year range. Adjustments are made to include new projects and an extra day in leap years.

Large Power Sales (Rate Schedule P)

The large power (Schedule P) sales forecast is developed using a combination of two forecast methods, the market analysis method in the near term (2019-2021) and an econometric model for the remainder of the forecast (2022-2050). The market analysis method is based on an analysis of the market conditions influencing different rate schedules with special emphasis on customer-by-customer accounting of loads in Large Power Schedule P services. Market analysis is the primary accepted near-term forecasting method for Schedule P services for Hawai'i Island, because the small number of large power customers (less than 100) allows for in-depth customer-by-customer analysis by the Company's Commercial



Account Managers. The expected addition or loss of specific Schedule P customers is also accounted for.

The large power econometric equation is specified using adjusted annual large power class sales in megawatt-hours (MWh). The adjusted sales are the annual large power MWh sales excluding the historical estimated impacts from each of the layers (DER, EE and EV) to result in underlying large power sales. This also includes impacts from significant transfers between rate classes, to reflect the accounts currently in the rate class.

The annual econometric model describes large power electricity sales as a function of large power electricity sales lagged by one year, non-farm jobs and two sets of binary dummy variables – 1) a dummy variable in 2001 and 2002 to account for impacts to large power sales from 9/11 and the lingering economic impacts and 2) a dummy variable for years with a U.S. recession in at least six months of the year. These variables were all found to have relationships with large power sales.

Additional details on each variable, dependent and independent, used in deriving the annual large power sales including the name of the variable and the source of the information are shown below. The values of the variables fed into the econometric modeling tool and the output from the model are contained in the Excel file “Appendix C Att 2 HL Underlying Inputs and Forecast.xlsx”.<sup>106</sup>

Table 11.17: Hawai'i Large Power Customer Econometric Sales Model Variables

Variable	Description	Source	Variable Labels
<i>Dependent Variable:</i>			
Large Power Sales	Adjusted P Sales (MWh)	Hawaiian Electric's monthly reports filed with the Commission	Adjusted P Sales (MWh)
<i>Lagged Dependent Variable:</i>			
Lagged Dependent Variable	Adjusted Schedule P Sales with one-year lag		Lagged Dependant - Adjusted P Sales (MWh) (1-year lag)
<i>Economic Variables:</i>			

<sup>106</sup> See <https://www.hawaiianelectric.com/clean-energy-hawaii/integrated-grid-planning/stakeholder-engagement/working-groups/forecast-assumptions-documents>





Annual Non-Farm Jobs	Non-Farm Jobs, Hawai'i County	UHERO, October 2019	Annual Non-Farm Jobs
<i>Dummy Variables:</i>			
Dummy variable 2001-2002	Proxy for 9/11 impacts	Improves model statistics	Dmy 911
Dummy variable for recessions	Dummy variable for years with a U.S. recession in at least 6 months	Improves model statistics	Dmy Recession

The resulting year-over-year growth rates from the annual sales econometric model are then applied to the 2020 customer service forecast to extend the forecast out to the full 30 year range . Adjustments are made to include large new projects and an extra day in leap years.

Street Lighting Sales (Schedule F)

The Schedule F forecast is developed using the customer service method for the duration of the forecast. Schedule F makes up a small portion (0.2-0.3%) of total Hawai'i Island sales and is less sensitive to economic drivers than the other rate schedules.

The trend in average annual kWh sales for new Schedule F customers in recent history (2016-2019) and the average number of new customers was analyzed, and those averages were applied to determine annual incremental kWh sales. The annual incremental kWh sales are then applied as year-over-year growth for the forecast horizon.

COVID-19 Update to the Underlying Sales for Hawai'i Island

Hawai'i Island stay-at-home orders went into effect on March 25, 2020 in conjunction with Governor Ige's initial statewide stay at home orders effective through April 30, 2020. Similar to O'ahu this order shutdown the visitor industry, schools and all but essential businesses.

A sales forecast update for the very near-term (2020 – 2021) was developed within the first month of the stay at home orders. This forecast used more judgmental techniques to update the very near-term forecast. More traditional econometric models using updated economic outlooks were developed for the years 2022-2025 assuming that more traditional economic relationships would resume even though the economy was expected to remain below pre-pandemic levels. UHERO's forecast update as of May 8, 2020 was utilized in developing the forecast update.



The 2020 update for Hawai'i Island was developed within less than two weeks of the shutdown. To develop the update, an analysis was done of daily system load after the shutdown compared to the same day in the prior year as well as in the weeks prior to the shutdown. This provided an estimate of total sales reductions on a percentage basis that were occurring under the stay-at-home orders and served as the lower bound of the monthly forecast. Based on the fast and furious changes in economic outlooks and information that could be gathered from various news sources, a corporate assumption of visitor arrivals beginning to resume in August became another bound of the forecast in that some recovery in electric sales would begin in August. The assumptions by customer class as describe below were assumed to be in place from April to July, with incremental recovery in August through October and an additional increment of recovery in November through December.

To assist in forecasting the different customer classes, hourly circuit data was obtained for selected circuits on Hawai'i Island that would be representative of heavily impacted sectors such as hotels, airports, retail and residential. The year-over-year changes as well as comparisons to before the shutdown from selected circuits helped to inform assumptions for residential and commercial sales reductions.

For residential sales, Hawai'i Island is unique compared to other islands in having a higher percentage of visitors reporting accommodations as rental homes or staying with family and friends. Also, there is a higher portion of service jobs and fewer traditional office jobs, where working from home may not be an option. The analysis of selected circuits serving predominantly residential customers across the island showed a mix of increased and decreased electricity usage. This supported the assumption that no changes would be made to the residential sales forecast in 2020.

For both large power and small/medium commercial sales, circuit analysis provided some guidance to potential sales losses in certain business sectors. In addition, estimated sales reductions by business sector were informed by judgmental analysis of sectors most likely to be impacted by the shutdown, the degree to which they would be impacted and recognizing that large power customers would be impacted differently than medium and small commercial customers in the same sector. These estimated reductions by sector were applied to the Schedule P customer by customer forecast to estimate the overall Schedule P sales reductions by month. Small commercial (Schedule G) and medium commercial (Schedule J) sales were analyzed separately with estimated percentage reductions applied to 2019 sales for the impacted sectors to determine estimated total year-over-year percentage reductions. These reductions were used as a guideline for the "all-in" forecast reductions for Schedule G and Schedule J. No forecast changes were made to Street Lighting (Schedule F). The total resulting reduction in the "all-in" forecast for April through July was compared to the average overall daily year-over-year system load reductions that were seen in the first few weeks after the shutdown to assess the reasonableness of the reductions. These reductions were then scaled back in three month increments over the remainder of the year.



No changes were assumed to the layers, so underlying sales was derived by taking the revised “all-in” sales by

The 2021 forecast was developed by incorporating an analysis of the losses in underlying sales by rate class during the Great Recession (2009 vs 2007) while also looking at the corresponding forecasted economic impacts compared to the Great Recession economic impacts. This was used to inform the forecast reductions by rate class.

From 2022-2025, the economic forecast data from the May 8, 2020 UHERO forecast update was used to rerun the econometric models for all rate classes. The resulting growth rates in underlying sales from these updated forecasts were applied to the 2021 forecast update underlying sales in order to derive the 2022-2025 forecasts. For all rate schedules except Schedule P, the forecast rejoined the original IGP forecast in 2026. For Schedule P the forecast update included an assumption that several new projects would each be delayed by a year, so the return to the IGP forecast did not occur until 2028.

### **Maui Island Underlying Forecast**

For Maui Island, the underlying forecast is developed by rate class - residential, small and medium commercial, large power and street lighting. Maui Island also used historical recorded sales in the models adjusted to remove sales impact of DER, EE and EoT.

#### Residential Sales

The residential underlying sales forecast is developed using the customer service method in 2019 and an econometric model for the remainder of the forecast period. The customer service method allows for factors including 2019 year to date sales, knowledge of local economic conditions such as construction activity, the state of the visitor industry and a review of short-term weather trends and conditions. The residential sales forecast for 2019 included actual Schedule R sales through September 2019 and a use per customer model for October through December.

The residential econometric equation specified using a residential class use per customer per month in kilowatt-hours. The monthly econometric model describes residential electricity use per customer as a function of real personal income per capita, electricity price, visitor arrivals and average billed days along with temperature humidity index interaction terms, dummy variables and moving average error terms. The model includes two interaction terms, one between real personal income per capita and temperature humidity index and the another between electricity price and temperature humidity index. There are also six monthly dummy variables included in the model used to account for seasonal variations in residential use per customer. In addition, there is a dummy variable that is used to calibrate 1995 with the other years in the historical data There are



also three moving average error terms that are used to improve the fit of the model.

The specification and evaluation of the hypothetical relationships was performed using a proprietary software package, MetrixND from Itron, Inc. Many hypothetical relationships were considered, tested, and rejected until econometric equations for residential use per customer and commercial kWh sales were identified for use in Hawaiian Electric’s sales projections.

Additional details on each variable, dependent and independent, used in deriving the monthly use per residential customer including the name of the variable and the source of the information are shown below. The values of the variables fed into the econometric modeling tool and the output from the model are contained in the Excel file “Appendix C Att 3 Maui Underlying Inputs and Predicted.xlsx”.<sup>107</sup>

Table 11.18: Maui Residential Customer Econometric Sales Model Variables

Variable	Description	Source	Variable Labels
<i>Dependent Variable:</i>			
Use per Customer	Adjusted Underlying Residential Sales ÷ Monthly Total Residential Customer Count	Hawaiian Electric’s monthly reports filed with the Commission	Adjusted Billed R Use Per Customer kWh
<i>Economic Variables:</i>			
12-Month Moving Average Real Personal Income Per Capita	Real Personal Income (1982-84 = 100) ÷ Resident Population (Maui County)	UHERO, October 2019	Adjusted Billed R Use Per Customer kWh
6-Month Moving Average Real Residential Electricity Price	Real residential dollars per kwh (1982-84=100) (Maui Island)	Internal Records, see FAWG presentation on August 27, 2019	Maui Island R Electricity Price 82-84\$/kWh, 6 Month Moving Average

<sup>107</sup> See <https://www.hawaiianelectric.com/clean-energy-hawaii/integrated-grid-planning/stakeholder-engagement/working-groups/forecast-assumptions-documents>



Monthly Visitor Arrivals	Visitor Arrivals (Maui Island), allocated to monthly values using historical patterns	UHERO, October 2019	Maui County Visitor Arrivals
Average Billed Days	Monthly Average Number of Billed Days	Internal Records	Days
<i>Weather Interaction Variables*:</i>			
12-Month Moving Average Real Personal Income Per Capita × Monthly THI	See Variable Descriptions	UHERO and NOAA	Real Income Per Capita - THI Degree Days Interaction
6-Month Moving Average Real Residential Electricity Price × Monthly THI	See Variable Descriptions	Internal Records and NOAA	Maui Island R Electricity Price 82-84\$/kWh - THI Degree Day Interaction
<i>Dummy Variables:</i>			
Monthly Dummy Variables	Dummy variable for six months found to seasonally differ from the base case, excluding Apr, Jul, Sep - Dec	Improves model statistics	Jan...Mar, May, June, Aug
Dummy Variable for All of 1995	Calibration factor for 1995	Improves model statistics	1995

To arrive at sales per month, the monthly use per residential customer derived in MetrixND was multiplied by the number of residential customers. The resulting residential GWh underlying sales forecast is residential kWh use per customer ÷ 10<sup>6</sup> × number of customers (Res\_rcd\_adj ÷ 10<sup>6</sup> × Res\_Cust\_rcd). An adjustment was made to include an extra day for leap year.



Growth rates from the econometric model are applied to the 2019 forecast to extend the forecast out to the full 30 year range.

Small and Medium Commercial Sales

The Maui Island the small and medium commercial underlying sales forecast is developed using the customer service method in 2019 and an econometric model for the remainder of the forecast period. Similarly, the small and medium commercial sales forecast for 2019 included actual Schedule G and Schedule J sales through September 2019 and a monthly customer service model for October through December.

The econometric model used for underlying small and medium commercial sales was modeled together since there are a significant number of rate transfers between the two commercial rate schedules on a regular basis (based on tariff requirements). The underlying small and medium commercial sales econometric equation was specified using monthly sales in kilowatt-hours. The monthly econometric model describes electricity sales as a function of real personal income, temperature humidity index, precipitation, Itron’s Statistically Adjusted End-Use (“SAE”) model’s monthly energy intensity index, and average billed days along with several monthly dummy variables and moving average error terms. There are seven consecutive monthly dummy variables included in the model used to account for seasonal variations in monthly underlying sales. There are also six moving average error terms that are used to improve the fit of the model.

Additional details on each variable, dependent and independent, used in deriving the monthly small and medium commercial customer sales including the name of the variable and the source of the information are shown below. The values of the variables fed into the econometric modeling tool and the output from the model are also contained in the Excel file “Appendix C Att 3 Maui Underlying Inputs and Predicted.xlsx”.<sup>108</sup>

Table 11.19: Maui Small and Medium Commercial Customer Econometric Sales Model Variables

Variable	Description	Source	Variable Labels
<i>Dependent Variable:</i>			
Underlying Small and Medium Commercial Sales	Monthly Adjusted Underlying Small and Medium Commercial Sales	Hawaiian Electric’s monthly reports filed with the Commission	Adjusted Billed GJ Sales MWh
<i>Economic Variables:</i>			

<sup>108</sup> See <https://www.hawaiianelectric.com/clean-energy-hawaii/integrated-grid-planning/stakeholder-engagement/working-groups/forecast-assumptions-documents>



12-Month Moving Average Real Personal Income	Real Personal Income (1982-84 = 100)	UHERO, October 2019	Maui Island Personal Income Mil 82-84\$, 12 Month Moving Average
Itron SAE Monthly Commercial Energy Intensity	Energy Intensity Index to Calibrate Historical Energy Usage	Itron, 2019 SAE Pacific Region	Monthly Commercial Energy Intensity
Average Billed Days	Monthly Average Number of Billed Days	Internal Records	Days
<i>Weather Variables*:</i>			
Monthly THI (temperature humidity index)	<p>Composite weather variable to incorporate both temperature and humidity.</p> <p>Wtd THI = <math>17.5 + (0.55 * \text{Wtd Avg Temperature}) + (0.20 * \text{Wtd Dewpoint})</math></p> <p>Forecast uses 20-year average (1999-2018) of weighted average temperature and weighted dewpoint to calculate THI. Warming trend included in forecasted average temperatures.</p>	Historical Kahului airport weather data from NOAA	THI Degree Days



Monthly Precipitation	Current month's rainfall in inches	Historical Kahului airport weather data from NOAA	Precipitation
1-Month Lagged Monthly Precipitation	Previous month's rainfall in inches	Historical Kahului airport weather data from NOAA	Precipitation Lag 1 Month
<i>Interaction Variables*:</i>			
Itron SAE Monthly Energy Intensity multiplied by Dummy variable for October 2017 forward	Energy Intensity Index to Calibrate Historical Energy Usage × Dummy for the months of October 2017 forward	Itron, 2019 SAE Pacific Region	Monthly Commercial Energy Intensity - October 2017 Forward Interaction
<i>Dummy Variables:</i>			
Monthly Dummy Variables	Dummy variable for seven consecutive months found to seasonally differ from the base case, excluding Jan-Apr, Dec	Improves model statistics	May - Nov

Growth rates from the econometric model are applied to the 2019 forecast to extend the forecast out to the full 30 year range.

Large Commercial Sales

The large commercial sales forecast is developed using market analysis techniques for the first three years and an econometric model for the forecast period after 2021. The market analysis is developed through ground up forecasting of each customer in the rate class. Commercial Account Managers (“CAMs”) work with customers in the rate class to forecast customer usage; accounting for individual projects, renovations, expansions, and changes in customer equipment. Within the market analysis, CAMs forecast customers’ underlying load, additional DER equipment, and energy efficiencies independently. Engineering requests for service, news articles, and county permitting information is also used to help forecast potential additions of new large loads or loss of large loads. Rate transfers between large commercial rate schedules and small and medium rate





schedules along with impending future transfers are also factored into the market analysis forecast.

In 2022, growth rates from the econometric model for underlying large commercial sales is used to forecast the remainder of the forecast period. This model is specified using monthly adjusted sales as a factor of real personal income, average billed days, and Itron’s SAE commercial energy intensity index, temperature humidity index, and precipitation along with one structural break interaction term and several dummy variables and moving average error terms. The model includes one interaction terms, between a structural break dummy from October 2017 forward and Itron’s SAE commercial energy intensity index. There are also six monthly dummy variables included in the model used to account for seasonal variations in large commercial sales. There are six moving average error terms that are used to improve the fit of the model.

Additional details on each variable, dependent and independent, used in deriving the monthly large commercial sales including the name of the variable and the source of the information are shown below. The values of the variables fed into the econometric modeling tool and the output from the model are also contained in the Excel file “Appendix C Att 3 Maui Underlying Inputs and Predicted.xlsx”.<sup>109</sup>

Table 11.20: Maui Large Power Customer Econometric Sales Model Variables

Variable	Description	Source	Variable Labels
<i>Dependent Variable:</i>			
Underlying Large Commercial Sales	Monthly Adjusted Underlying Large Commercial Sales	Hawaiian Electric’s monthly reports filed with the Commission	Adjusted Billed P Sales MWh
<i>Economic Variables:</i>			
12-Month Moving Average Real Personal Income	12-Month Moving Average Real Personal Income (1982-84 = 100) (Maui County)	UHERO, October 2019	Maui Island Personal Income Mil 82-84\$, 12 Month Moving Average
Itron SAE Monthly Commercial Energy Intensity	Energy Intensity Index to Calibrate	Itron, 2019 SAE Pacific Region	Monthly Commercial Energy Intensity

<sup>109</sup> See <https://www.hawaiianelectric.com/clean-energy-hawaii/integrated-grid-planning/stakeholder-engagement/working-groups/forecast-assumptions-documents>



	Historical Energy Usage		
Average Billed Days	Monthly Average Number of Billed Days	Hawaiian Electric's monthly reports filed with the Commission	Days
<i>Weather Variables*:</i>			
Maui Temperature-Humidity Cooling Degree Days	Annual sum of daily temperature-humidity index in excess of 85	Historical Kahului airport weather data from NOAA	THI Degree Days
Monthly Precipitation	Current month's rainfall in inches	Historical Kahului airport weather data from NOAA	Precipitation
<i>Structural Break Interaction Variables*:</i>			
Itron SAE Monthly Energy Intensity multiplied by Dummy variable for October 2017 forward	Energy Intensity Index to Calibrate Historical Energy Usage × Dummy for the months of October 2017 forward	Itron, 2019 SAE Pacific Region	Monthly Commercial Energy Intensity - October 2017 Forward Interaction
<i>Dummy Variables:</i>			
Monthly Dummy Variables	Dummy variable for six months found to seasonally differ from the base case, excluding Jan, Mar-May, Sep, Dec	Improves model statistics	Feb, Jun... Aug, Oct, Nov

Street Lighting Sales (Schedule F)



The Schedule F forecast is developed using the customer service method for 2019 to 2023 and a trending model for the remaining duration of the forecast period. Schedule F makes up a small portion (0.4-0.6%) of total Maui Island sales and is less sensitive to economic drivers than the other rate schedules. While historical schedule F sales have been relatively flat, the customer service portion of the forecast reflects a significant decline in sales, as the planned replacement of existing streetlight fixtures with LED fixtures are executed. The customer service approach takes into consideration the information and replacement schedule provided by the engineering department tasked with the conversion. Schedule F sales are expected to decrease to less than half of the historical level during the years of the customer service portion of the forecast. Thereafter, growth rates from the linear trend model that accounts for monthly seasonality are applied to forecast the remaining years of the forecast period.

#### COVID-19 Update to the Underlying Sales

Stay-at-home orders went into effect on March 25, 2020 in conjunction with Governor Ige's initial statewide stay at home orders effective through April 30, 2020. Similar to the other islands this order shutdown the visitor industry, schools and all but essential businesses.

For the very near term, 2020-2021, the commercial forecast was developed using several sources of information. Where available, customer data from before and after the shutdown orders went into effect, customer announcements regarding closures, and feedback from customers to their Hawaiian Electric account managers were analyzed to produce an estimate of the immediate impact (percent change). The impacts were used as a proxy for the commercial sectors by business types (e.g., hotel, office, retail, education). UHERO updates were used to estimate the length of time the lowest economic activity would continue and how long it would take to see recovery.

The residential sector was initially difficult to estimate because meter reads were halted due to safety concerns for customers and meter readers. Residential customers' bills were estimated from late March until mid-May 2020 using prior consumption, which was low relative to residential usage under the stay-at-home order. Real time circuit level energy data for a sample of residential areas was used to help derive a high-level impact factor to apply to total residential sales. As billing data became available, the initial forecast was refined and updated.

In the longer run (2022-2025), the economic outlook from UHERO was used to update econometric models. For 2022, results from the econometric models were averaged with the 2021 forecast in order to smooth the transition from the near-term forecast and the econometric models. Following 2025, the forecast transitions to the previously developed IGP forecast. Smoothing of the transition was performed by applying adjustment factors of 0.985-0.995 to the underlying sales from 2026-2028.



## Lānaʻi Island Underlying Forecast

The Lānaʻi underlying forecast is developed by rate class - residential, small and medium commercial, large power and street lighting. Lānaʻi also used historical recorded sales in the models adjusted to remove sales impact of DER, EE and EoT.

### Residential Sales

The residential underlying sales forecast is developed using the customer service method for 2019 to 2022 and an econometric model for the remainder of the forecast period. The customer service method allows for factors including 2019 year to date sales, knowledge of local economic conditions such as construction activity, the state of the visitor industry and a review of short-term weather trends and conditions. The residential sales forecast for 2019 included actual Schedule R sales through September 2019 and a use per customer model for October through December. This portion of the forecast was primarily derived from an analysis on forecasted customer count and average use per customer trends.

The residential econometric equation is specified using a residential class annual sales model in megawatt-hours. The annual econometric model describes adjusted underlying residential electricity sales as a function of customer counts, previous year’s real electricity price, a dummy variable for 2007, and a 1-year lagged dependent variable.

Additional details on each variable, dependent and independent, used in deriving the monthly use per residential customer including the name of the variable and the source of the information are shown below. The values of the variables fed into the econometric modeling tool and the output from the model are contained in the Excel file “Appendix C Att 4 Lanai Underlying Inputs and Predicted.xlsx”.<sup>110</sup>

Table 11.21: Lānaʻi Residential Customer Econometric Sales Model Variables

Variable	Description	Source	Variable Labels
<i>Dependent Variable:</i>			
Annual Adjusted Underlying Sales	Adjusted underlying residential sales	Internal Records	Adjusted Billed R Sales MWh
<i>Economic Variables:</i>			
Annual Residential	Number of customers in the	Hawaiian Electric’s monthly	Residential class customer count

<sup>110</sup> See <https://www.hawaiianelectric.com/clean-energy-hawaii/integrated-grid-planning/stakeholder-engagement/working-groups/forecast-assumptions-documents>



Customer Counts	residential rate class by year	reports filed with the Commission	
I-Year Lagged Real Residential Electricity Price	Average annual real residential dollars per kwh from previous year (1982-84=100) (Lāna'i)	Internal Records, see FAWG presentation on August 27, 2019	Real residential electricity price lag one year
I-Year Lagged Dependent	Adjusted underlying residential sales from previous year (MWH)	Internal Records	Lagged Dependent
<i>Dummy Variables:</i>			
2007 Calibration Dummy Variable	Binary variable coded as 1 for year 2007 and 0 for all other years	Calibrates 2007 and improves model statistics	Dummy 2007

Growth rates from the econometric model are applied to the 2022 forecast to extend the forecast out to the full 30 year range.

Small and Medium Commercial Sales

The Lāna'i small and medium commercial underlying sales forecast is developed using the customer service method in 2019 through 2021 and a trending model for the remainder of the forecast period. Similarly, the small and medium commercial sales forecast for 2019 included actual Schedule G and Schedule J sales through September 2019 and a monthly customer service model for October through December. The opening of The Lodge at Koele has stimulated and supported growth in small and medium commercial sales in 2019 and expected to continue for a portion of 2020. The customer service model assumed a leveling-off in growth for 2021 sales to the 5-Year (2014-2018) historical average growth rate for the small and medium commercial sectors.

After 2021, the trending model used growth rates from a damped exponential smoothing function to forecast the small and medium commercial sales to 2050.

Large Commercial Sales

The large commercial sales forecast is developed using market analysis techniques for the first three years and the customer service method for the forecast period



after 2021. The market analysis is developed through ground up forecasting of each customer in the rate class. CAMs develop sales forecast with customers in the rate class to forecast underlying usage and sales to account for individual projects, renovations, expansions, and changes in customer equipment. Like the market analysis for Maui Island, CAMs forecast Lānaʻi customers' underlying load, additional DER equipment, and energy efficiencies independent and alongside the underlying sales. Engineering request, news articles, and county permitting information is also used to help forecast potential additions or loss of large loads. Rate transfers between large commercial rate schedules and small and medium rate schedules along with impending future transfers are also factored into the market analysis forecast. With the launch of Sensei Lānaʻi, A Four Seasons Resort (formerly The Lodge at Koele), sales for the large commercial sector on Lānaʻi are expected to increase substantially in the near term. This expected growth is captured in the market analysis portion of the forecast.

For 2022 forward, the customer service method is used to forecast underlying sales in the large commercial sector for Lānaʻi. In 2022 with Sensei Lānaʻi fully operational, growth in the sector is expected to level off. A growth rate of 0.2% annual increase in underlying sales was applied to carry the market analysis forecast out to 2050.

#### Street Lighting Sales (Schedule F)

The Schedule F forecast is developed using the customer service method for 2019 to 2023 and a trending model for the remaining duration of the forecast period. Schedule F makes up a small portion (0.4-0.6%) of total Lānaʻi. The customer service portion of the forecast reflects a significant decline in sales, as the planned replacement of existing streetlight fixtures with LED fixtures are executed. The customer service approach takes into consideration the information and replacement schedule provided by the engineering department tasked with the conversion. Schedule F sales are expected to decrease to less than half of the historical level (114-137 MWh annually) during the years of the customer service portion of the forecast. Thereafter, sales are expected to remain flat at 42 MWh annually for the remainder of the forecast.

#### **Molokaʻi Island Underlying Forecast**

The Molokaʻi underlying forecast is developed by rate class - residential, small and medium commercial, large power and street lighting. Molokaʻi also used historical recorded sales in the models adjusted to remove sales impact of DER, EE and EoT.

#### Residential Sales

The residential underlying sales forecast is developed using the customer service method for 2019 to 2023 and an econometric model for the remainder of the forecast period. The customer service method allows for factors including 2019 year to date sales, knowledge of local economic conditions such as construction



activity, the state of the visitor industry and a review of short-term weather trends and conditions. The residential sales forecast for 2019 included actual Schedule R sales through September 2019 and a use per customer derived forecast for October through December. The customer service portion of the forecast was primarily derived from an analysis on forecasted customer count and use per customer trends.

The residential econometric equation is specified using a residential class annual sales model in megawatt-hours. The annual econometric model describes adjusted underlying residential electricity sales as a function of real personal income, real electricity price, the annual sum of cooling degree days from Maui’s temperature-humidity index, and a 1-year lagged dependent variable.

Additional details on each variable, dependent and independent, used in deriving the monthly use per residential customer including the name of the variable and the source of the information are shown below. The values of the variables fed into the econometric modeling tool and the output from the model are contained in the Excel file “Appendix C Att 5 Molokai Underlying Inputs and Predicted.xlsx”.<sup>111</sup>

Table 11.22: Moloka’i Residential Customer Econometric Sales Model Variables

Variable	Description	Source	Variable Labels
<i>Dependent Variable:</i>			
Annual Adjusted Underlying Sales	Adjusted underlying residential sales	Hawaiian Electric’s monthly reports filed with the Commission	Adjusted Billed R Sales MWh
<i>Economic Variables:</i>			
Real Personal Income	Real Personal Income (1982-84 = 100)	UHERO, October 2019	Molokai Personal Income Mil 82-84\$
Real Residential Electricity Price	Average annual real residential dollars per kwh from previous year (1982-84=100) (Moloka’i)	Internal Records, see FAWG presentation on August 27, 2019	Molokai R Electricity Price 82-84cents/kWh
I-Year Lagged Dependent	Adjusted underlying residential sales from previous year (MWH)	Internal Records	Lagged Dependent

<sup>111</sup> See <https://www.hawaiianelectric.com/clean-energy-hawaii/integrated-grid-planning/stakeholder-engagement/working-groups/forecast-assumptions-documents>



<i>Weather Variables*:</i>			
Maui Temperature-Humidity Cooling Degree Days	Annual sum of daily temperature-humidity index in excess of 85	Historical Kahului airport weather data from NOAA	THI Degree Days

Growth rates from the econometric model are applied to the 2020 forecast to extend the forecast out to the full 30 year range.

Small and Medium Commercial Sales

The Moloka'i small and medium commercial underlying sales forecast is developed using the customer service method for the entire forecast period. Actual sales through September 2019 were used, with a monthly forecast for October through December of 2019 and an annual growth model thereafter. Without the advent of large changes in load for the small and medium commercial sector in the foreseeable future, a growth rate of 0.2% was assumed for 2020 to 2050.

Large Commercial Sales

The large commercial sales forecast is developed using market analysis techniques for the first three years and a trending model for the forecast period after 2021. The market analysis is developed through ground up forecasting of each customer in the rate class. CAMs develop sales forecast with customers in the rate class to forecast underlying usage and sales to account for individual projects, renovations, expansions, and changes in customer equipment. CAMs forecast Moloka'i customers' underlying load, additional DER equipment, and energy efficiencies independent and alongside the underlying sales. Engineering request, news articles, and county permitting information is also used to help forecast potential additions or loss of large loads. Rate transfers between large commercial rate schedules and small and medium rate schedules along with impending future transfers are also factored into the market analysis forecast.

For 2022 forward, the trend analysis is used to forecast underlying sales in the large commercial sector for Moloka'i. The 5-year average growth rate of 0.18% annual increase in underlying sale was applied to carry the market analysis forecast out to 2050.

Street Lighting Sales (Schedule F)

The Schedule F forecast is developed using the customer service method for 2019 to 2023 and a trending model for the remaining duration of the forecast period. Schedule F makes up a small portion (1.3-2.0%) of total Moloka'i. The customer service portion of the forecast reflects a significant decline in sales, as the planned replacement of existing streetlight fixtures with LED fixtures are executed. The





customer service approach takes into consideration the information and replacement schedule provided by the engineering department tasked with the conversion. Schedule F sales are expected to decrease to less than half of the historical level (450-560 MWh annually) during the years of the customer service portion of the forecast. Thereafter, sales are expected to remain flat at 240 MWh annually for the remainder of the forecast.

#### COVID-19 Update to the Underlying Sales for Lānaʻi and Molokaʻi

The unique character of each island has to be considered when choosing methods for forecasting the impact of a major disruption such as the Covid-19 pandemic. The impact of Covid to 2020 sales has varied significantly among the islands. The most likely explanation is the relative dependency of each island's economy on tourism. Molokaʻi, being the least tourism dependent, exhibited little to no impact in total kWh sales from the Covid shutdowns. Maui and Lānaʻi, being the most dependent on tourism, experienced the largest impacts to total kWh sales.

On Lānaʻi, the Pulama Lānaʻi resorts are the most significant driver of the island's electricity consumption. The forecast for Lānaʻi assumes that the resorts would resume operation as soon as travel to the island was allowed without post-travel quarantine. Therefore, Covid-19 impacts to the Lānaʻi underlying forecast were limited to 2020 with no change to the forecast thereafter.

On Molokaʻi, the forecast for 2020 was updated to include an increase in residential kWh sales and reduction to commercial sales due to stay-at-home orders. The Covid-19 impacts in the forecast for Molokaʻi were limited to 2020 with no change to the forecast thereafter.



## Appendix D: Sales Forecasts (2020 – 2050)

Table 11.23: O’ahu Sales Forecast

Year	Underlying	Distributed Energy Resources (PV and BESS)	Energy Efficiency	Electric Vehicles	Customer Level Sales Forecast
GWH	A	B	C	D	E = A + B + C + D
2020	8,106	(936)	(1,396)	30	5,805
2021	8,690	(991)	(1,509)	38	6,228
2022	8,936	(1,093)	(1,613)	49	6,279
2023	9,094	(1,179)	(1,703)	61	6,274
2024	9,276	(1,226)	(1,793)	75	6,332
2025	9,456	(1,255)	(1,887)	92	6,407
2026	9,638	(1,287)	(1,980)	111	6,482
2027	9,745	(1,319)	(2,067)	134	6,493
2028	9,873	(1,355)	(2,153)	159	6,524
2029	9,988	(1,384)	(2,232)	187	6,561
2030	10,133	(1,415)	(2,307)	221	6,632
2031	10,237	(1,445)	(2,383)	257	6,666
2032	10,345	(1,478)	(2,462)	297	6,702
2033	10,447	(1,500)	(2,530)	342	6,759
2034	10,533	(1,524)	(2,595)	392	6,805
2035	10,617	(1,547)	(2,654)	447	6,863
2036	10,731	(1,571)	(2,713)	501	6,948
2037	10,792	(1,587)	(2,760)	561	7,007
2038	10,875	(1,605)	(2,809)	624	7,085
2039	10,972	(1,622)	(2,860)	700	7,190
2040	11,110	(1,642)	(2,917)	789	7,341
2041	11,152	(1,653)	(2,963)	892	7,427
2042	11,232	(1,668)	(3,012)	1,006	7,557
2043	11,322	(1,682)	(3,057)	1,120	7,703
2044	11,443	(1,699)	(3,105)	1,238	7,877
2045	11,499	(1,707)	(3,142)	1,366	8,016
2046	11,582	(1,717)	(3,183)	1,497	8,179
2047	11,662	(1,728)	(3,223)	1,631	8,343
2048	11,773	(1,742)	(3,266)	1,760	8,525



Integrated Grid Planning Inputs and Assumptions | August 2021 Update

2049	11,823	(1,747)	(3,297)	1,871	8,650
2050	11,905	(1,756)	(3,332)	1,964	8,781



Table 11.24: Hawai'i Island Sales Forecast

Year	Underlying	Distributed Energy Resources (PV and BESS)	Energy Efficiency	Electric Vehicles	Customer Level Sales Forecast
GWH	A	B	C	D	E = A + B + C + D
2020	1,345	(179)	(185)	2	983
2021	1,373	(195)	(204)	3	978
2022	1,410	(205)	(221)	4	987
2023	1,433	(214)	(237)	5	986
2024	1,456	(222)	(253)	6	988
2025	1,471	(228)	(268)	10	986
2026	1,483	(234)	(284)	15	980
2027	1,496	(241)	(300)	19	974
2028	1,516	(249)	(316)	25	976
2029	1,524	(256)	(331)	32	969
2030	1,535	(263)	(345)	39	967
2031	1,547	(271)	(359)	47	964
2032	1,561	(278)	(374)	56	965
2033	1,566	(284)	(387)	66	961
2034	1,575	(291)	(400)	77	963
2035	1,584	(297)	(411)	93	970
2036	1,598	(304)	(422)	107	979
2037	1,603	(308)	(431)	121	985
2038	1,612	(314)	(440)	137	994
2039	1,621	(319)	(450)	154	1,005
2040	1,634	(325)	(461)	172	1,020
2041	1,637	(329)	(469)	192	1,031
2042	1,646	(334)	(478)	214	1,048
2043	1,654	(338)	(486)	238	1,068
2044	1,666	(343)	(495)	262	1,090
2045	1,670	(346)	(501)	288	1,110
2046	1,678	(350)	(509)	315	1,134
2047	1,685	(354)	(516)	345	1,160
2048	1,698	(358)	(524)	374	1,190
2049	1,700	(361)	(529)	404	1,214
2050	1,708	(364)	(535)	435	1,244



Table 11.25: Maui Sales Forecast

Year	Underlying	Distributed Energy Resources (PV and BESS)	Energy Efficiency	Electric Vehicles	Customer Level Sales Forecast
GWH	A	B	C	D	E = A + B + C + D
2020	1,343	(202)	(219)	3	925
2021	1,409	(222)	(238)	4	953
2022	1,415	(237)	(255)	6	928
2023	1,425	(252)	(270)	8	911
2024	1,453	(263)	(285)	10	914
2025	1,474	(271)	(300)	14	917
2026	1,499	(280)	(315)	20	924
2027	1,521	(288)	(329)	28	932
2028	1,542	(297)	(344)	37	938
2029	1,556	(304)	(358)	46	939
2030	1,572	(312)	(371)	56	945
2031	1,586	(320)	(384)	70	952
2032	1,606	(329)	(397)	87	967
2033	1,620	(335)	(409)	107	982
2034	1,635	(341)	(421)	127	1,000
2035	1,649	(347)	(431)	147	1,018
2036	1,668	(354)	(440)	168	1,042
2037	1,678	(359)	(448)	189	1,060
2038	1,693	(364)	(456)	211	1,083
2039	1,707	(369)	(464)	233	1,107
2040	1,726	(374)	(473)	255	1,134
2041	1,733	(377)	(480)	277	1,153
2042	1,746	(381)	(486)	299	1,178
2043	1,760	(384)	(493)	319	1,203
2044	1,778	(389)	(500)	338	1,228
2045	1,787	(390)	(505)	357	1,248
2046	1,800	(393)	(510)	375	1,271
2047	1,813	(396)	(516)	392	1,294
2048	1,832	(399)	(521)	410	1,320
2049	1,839	(401)	(525)	426	1,339
2050	1,852	(403)	(529)	443	1,363



Table 11.26: Moloka'i Sales Forecast

Year	Underlying	Distributed Energy Resources (PV and BESS)	Energy Efficiency	Electric Vehicles	Customer Level Sales Forecast
GWH	A	B	C	D	E =A + B + C + D
2020	35.6	(4.6)	(2.7)	0.1	28.4
2021	36.2	(5.1)	(2.8)	0.1	28.4
2022	36.0	(5.3)	(2.9)	0.1	27.9
2023	36.0	(5.5)	(2.9)	0.1	27.6
2024	36.1	(5.7)	(3.0)	0.1	27.4
2025	36.0	(5.8)	(3.1)	0.1	27.2
2026	36.1	(5.8)	(3.2)	0.1	27.1
2027	36.2	(6.0)	(3.3)	0.2	27.0
2028	36.3	(6.2)	(3.4)	0.2	26.9
2029	36.3	(6.3)	(3.5)	0.2	26.7
2030	36.4	(6.5)	(3.6)	0.3	26.6
2031	36.5	(6.6)	(3.7)	0.3	26.5
2032	36.7	(6.8)	(3.7)	0.3	26.5
2033	36.8	(6.9)	(3.8)	0.4	26.5
2034	37.0	(7.0)	(3.9)	0.5	26.5
2035	37.1	(7.2)	(4.0)	0.5	26.5
2036	37.3	(7.3)	(4.0)	0.6	26.7
2037	37.4	(7.3)	(4.1)	0.7	26.7
2038	37.5	(7.4)	(4.1)	0.8	26.8
2039	37.6	(7.5)	(4.2)	0.9	26.9
2040	37.8	(7.7)	(4.2)	1.1	27.0
2041	37.8	(7.7)	(4.3)	1.3	27.1
2042	37.9	(7.8)	(4.3)	1.4	27.3
2043	38.1	(7.8)	(4.4)	1.7	27.5
2044	38.3	(7.9)	(4.4)	1.9	27.7
2045	38.3	(8.0)	(4.5)	2.1	27.9
2046	38.4	(8.1)	(4.5)	2.3	28.1
2047	38.5	(8.1)	(4.6)	2.6	28.4
2048	38.8	(8.2)	(4.6)	2.8	28.8
2049	38.8	(8.2)	(4.7)	3.0	29.0
2050	38.9	(8.2)	(4.7)	3.2	29.3



Table 11.27: Lānaʻi Sales Forecast

Year	Underlying	Distributed Energy Resources (PV and BESS)	Energy Efficiency	Electric Vehicles	Customer Level Sales Forecast
GWH	A	B	C	D	E =A + B + C + D
2020	34.3	(1.4)	(1.1)	0.1	31.9
2021	40.0	(1.4)	(1.2)	0.1	37.5
2022	40.1	(1.5)	(1.3)	0.1	37.4
2023	40.2	(1.6)	(1.4)	0.1	37.3
2024	40.6	(1.7)	(1.5)	0.1	37.5
2025	40.8	(1.7)	(1.6)	0.1	37.6
2026	41.1	(1.8)	(1.7)	0.1	37.8
2027	41.4	(1.9)	(1.8)	0.1	37.9
2028	41.9	(2.0)	(1.9)	0.1	38.2
2029	42.0	(2.0)	(1.9)	0.1	38.2
2030	42.2	(2.1)	(2.0)	0.2	38.2
2031	42.4	(2.2)	(2.1)	0.2	38.2
2032	42.7	(2.3)	(2.2)	0.2	38.4
2033	42.8	(2.4)	(2.3)	0.3	38.4
2034	43.0	(2.5)	(2.4)	0.3	38.4
2035	43.1	(2.6)	(2.4)	0.4	38.5
2036	43.4	(2.6)	(2.5)	0.4	38.8
2037	43.5	(2.7)	(2.6)	0.5	38.7
2038	43.6	(2.8)	(2.6)	0.5	38.8
2039	43.8	(2.8)	(2.7)	0.6	38.9
2040	44.1	(2.9)	(2.8)	0.7	39.1
2041	44.1	(3.0)	(2.8)	0.8	39.1
2042	44.3	(3.0)	(2.9)	0.9	39.3
2043	44.4	(3.1)	(2.9)	1.0	39.5
2044	44.7	(3.1)	(3.0)	1.1	39.8
2045	44.7	(3.2)	(3.0)	1.3	39.8
2046	44.9	(3.3)	(3.1)	1.4	40.0
2047	45.1	(3.3)	(3.2)	1.6	40.2
2048	45.3	(3.3)	(3.2)	1.7	40.5
2049	45.4	(3.3)	(3.3)	1.8	40.6
2050	45.6	(3.4)	(3.3)	1.9	40.8



## Appendix E: Peak Forecasts (2020 – 2050)

Table 11.28: O’ahu Peak Forecast (MW)

Year	Underlying	Distributed Energy Resources (PV and BESS)	Energy Efficiency	Electric Vehicles	Peak Forecast
MW	A	B	C	D	E = A + B + C + D
2020	1,330	(5)	(258)	6	1,072
2021	1,405	(13)	(282)	8	1,117
2022	1,496	(30)	(297)	9	1,178
2023	1,517	(47)	(310)	11	1,170
2024	1,552	(58)	(335)	13	1,173
2025	1,579	(60)	(339)	16	1,196
2026	1,569	(66)	(351)	19	1,171
2027	1,589	(75)	(366)	23	1,173
2028	1,590	(69)	(381)	29	1,169
2029	1,617	(91)	(388)	33	1,171
2030	1,642	(95)	(402)	39	1,184
2031	1,667	(97)	(414)	46	1,202
2032	1,683	(99)	(424)	54	1,214
2033	1,703	(95)	(434)	62	1,236
2034	1,712	(101)	(440)	72	1,243
2035	1,718	(104)	(448)	82	1,248
2036	1,738	(106)	(455)	94	1,271
2037	1,762	(117)	(465)	106	1,286
2038	1,780	(120)	(476)	121	1,305
2039	1,792	(121)	(483)	135	1,323
2040	1,736	(87)	(454)	145	1,339
2041	1,747	(90)	(466)	177	1,369
2042	1,639	(43)	(437)	237	1,396
2043	1,852	(140)	(508)	223	1,427
2044	1,800	(97)	(474)	241	1,470
2045	1,702	(43)	(452)	286	1,493
2046	1,682	(43)	(459)	359	1,538
2047	1,704	(49)	(464)	392	1,582
2048	1,707	(46)	(469)	424	1,615





Integrated Grid Planning Inputs and Assumptions | August 2021 Update

2049	1,712	(52)	(473)	453	1,640
2050	1,721	(51)	(477)	473	1,666



Table 11.29: Hawai'i Island Peak Forecast (MW)

Year	Underlying	Distributed Energy Resources (PV and BESS)	Energy Efficiency	Electric Vehicles	Peak Forecast
MW	A	B	C	D	E=A + B + C + D
2020	221.6	(0.8)	(29.5)	0.4	191.8
2021	218.8	(2.8)	(36.8)	0.6	179.8
2022	219.8	(4.2)	(35.7)	0.8	180.8
2023	228.1	(6.1)	(43.0)	1.1	180.1
2024	224.2	(6.6)	(41.0)	1.5	178.1
2025	229.5	(10.0)	(42.6)	2.1	178.9
2026	229.4	(7.2)	(45.8)	3.2	179.6
2027	234.2	(12.2)	(47.8)	4.2	178.3
2028	234.5	(10.4)	(50.7)	5.0	178.5
2029	250.1	(21.0)	(58.1)	7.1	178.1
2030	236.8	(12.5)	(55.5)	8.7	177.5
2031	241.1	(17.9)	(57.0)	10.3	176.5
2032	239.3	(12.1)	(60.7)	11.5	178.1
2033	243.8	(15.5)	(62.3)	15.3	181.2
2034	233.6	(3.2)	(68.9)	17.5	178.9
2035	243.0	(9.0)	(74.7)	21.3	180.6
2036	247.4	(23.4)	(67.1)	23.6	180.6
2037	240.2	(3.3)	(72.8)	26.0	190.2
2038	240.1	(3.3)	(74.0)	27.8	190.5
2039	240.4	(5.4)	(76.1)	35.4	194.3
2040	249.9	(10.8)	(84.2)	39.6	194.5
2041	252.3	(22.2)	(75.7)	42.2	196.6
2042	255.4	(29.3)	(77.6)	48.1	196.6
2043	247.7	(3.4)	(82.2)	51.5	213.6
2044	246.4	(5.8)	(82.7)	60.2	218.1
2045	247.2	(3.4)	(85.3)	64.5	223.1
2046	257.2	(12.5)	(93.5)	73.1	224.3
2047	218.1	(2.8)	(73.1)	88.0	230.1
2048	253.4	(3.5)	(89.0)	81.1	242.1
2049	253.1	(9.1)	(93.6)	91.2	241.6
2050	256.5	(3.8)	(99.6)	99.3	252.4



Table 11.30: Maui Peak Forecast (MW)

Year	Underlying	Distributed Energy Resources (PV and BESS)	Energy Efficiency	Electric Vehicles	Peak Forecast
MW	A	B	C	D	E = A + B + C + D
2020	229.7	(1.7)	(34.1)	0.1	194.0
2021	237.2	(3.2)	(38.5)	0.2	195.7
2022	236.9	(8.5)	(41.5)	0.6	187.5
2023	238.0	(12.4)	(42.4)	1.0	184.2
2024	242.4	(16.2)	(44.7)	1.5	183.0
2025	246.7	(18.0)	(47.3)	2.2	183.6
2026	250.8	(20.0)	(52.1)	3.6	182.3
2027	250.2	(15.6)	(55.8)	5.5	184.3
2028	252.5	(16.2)	(59.2)	7.2	184.3
2029	259.5	(26.6)	(56.6)	8.7	185.0
2030	261.1	(29.2)	(58.1)	11.4	185.2
2031	254.0	(22.9)	(58.0)	13.1	186.2
2032	246.6	(11.3)	(59.8)	16.3	191.8
2033	250.0	(11.5)	(61.6)	21.0	197.9
2034	252.8	(11.8)	(63.1)	26.4	204.2
2035	231.7	(3.8)	(58.9)	36.4	205.4
2036	267.3	(21.6)	(76.7)	38.7	207.7
2037	257.2	(13.0)	(66.5)	37.8	215.5
2038	260.4	(13.3)	(67.5)	40.2	219.8
2039	263.0	(13.6)	(68.9)	46.5	226.9
2040	241.4	(3.9)	(64.6)	63.3	236.2
2041	243.6	(5.8)	(64.3)	69.1	242.6
2042	245.8	(11.8)	(65.1)	75.1	244.0
2043	273.2	(14.8)	(72.5)	64.0	249.9
2044	291.3	(29.5)	(81.4)	75.3	255.7
2045	255.4	(4.1)	(67.7)	77.8	261.4
2046	252.2	(4.1)	(68.7)	93.8	273.2
2047	254.5	(6.0)	(69.4)	98.1	277.1
2048	287.3	(16.0)	(76.9)	82.0	276.3
2049	258.8	(16.7)	(70.7)	107.7	279.2
2050	260.3	(16.8)	(71.2)	111.5	283.8



Table 11.31: Moloka'i Peak Forecast (MW)

Year	Underlying	Distributed Energy Resources (PV and BESS)	Energy Efficiency	Electric Vehicles	Peak Forecast
MW	A	B	C	D	E = A + B + C + D
2020	5.7	(0.0)	0.0	0.0	5.7
2021	5.7	(0.0)	(0.0)	0.0	5.6
2022	5.7	(0.0)	(0.1)	0.0	5.6
2023	5.7	(0.1)	(0.1)	0.0	5.5
2024	5.7	(0.1)	(0.1)	0.0	5.6
2025	5.8	(0.1)	(0.1)	0.0	5.6
2026	5.8	(0.1)	(0.1)	0.0	5.6
2027	5.7	(0.1)	(0.2)	0.0	5.5
2028	5.8	(0.1)	(0.1)	0.0	5.5
2029	5.8	(0.2)	(0.2)	0.0	5.6
2030	5.8	(0.1)	(0.2)	0.0	5.6
2031	5.9	(0.2)	(0.2)	0.1	5.6
2032	5.9	(0.2)	(0.2)	0.1	5.6
2033	5.9	(0.2)	(0.3)	0.1	5.6
2034	5.8	(0.2)	(0.2)	0.1	5.6
2035	6.1	(0.2)	(0.3)	0.1	5.7
2036	6.1	(0.3)	(0.2)	0.1	5.7
2037	6.0	(0.2)	(0.2)	0.2	5.7
2038	6.1	(0.2)	(0.2)	0.2	5.9
2039	6.1	(0.2)	(0.2)	0.2	5.9
2040	6.1	(0.2)	(0.2)	0.2	5.9
2041	6.1	(0.3)	(0.2)	0.3	5.9
2042	6.2	(0.3)	(0.2)	0.3	6.0
2043	6.2	(0.3)	(0.2)	0.4	6.1
2044	6.4	(0.3)	(0.3)	0.5	6.2
2045	6.3	(0.3)	(0.2)	0.5	6.3
2046	6.3	(0.3)	(0.2)	0.5	6.4
2047	6.4	(0.3)	(0.2)	0.6	6.5
2048	6.4	(0.3)	(0.2)	0.6	6.5
2049	6.4	(0.3)	(0.2)	0.7	6.6
2050	6.5	(0.3)	(0.2)	0.8	6.7



Table 11.32: Lānaʻi Peak Forecast (MW)

Year	Underlying	Distributed Energy Resources (PV and BESS)	Energy Efficiency	Electric Vehicles	Peak Forecast
MW	A	B	C	D	E = A + B + C + D
2020	5.9	-	-	-	5.9
2021	6.3	-	-	-	6.3
2022	6.3	-	-	-	6.3
2023	6.5	-	(0.1)	-	6.4
2024	6.5	-	(0.1)	-	6.4
2025	6.5	-	(0.1)	-	6.4
2026	6.5	-	(0.1)	-	6.4
2027	6.6	-	(0.1)	-	6.5
2028	6.7	-	(0.2)	-	6.5
2029	6.8	(0.1)	(0.2)	-	6.5
2030	6.8	(0.1)	(0.2)	-	6.6
2031	6.8	(0.1)	(0.2)	-	6.5
2032	6.8	(0.1)	(0.2)	-	6.5
2033	6.8	(0.1)	(0.2)	-	6.5
2034	6.9	(0.1)	(0.3)	0.1	6.6
2035	7.0	(0.1)	(0.3)	0.1	6.7
2036	7.0	(0.1)	(0.2)	0.1	6.7
2037	7.0	(0.1)	(0.3)	0.1	6.7
2038	7.0	(0.1)	(0.3)	0.1	6.7
2039	7.1	(0.1)	(0.3)	0.1	6.8
2040	7.2	(0.1)	(0.3)	0.1	6.9
2041	7.2	(0.1)	(0.3)	0.2	6.9
2042	7.2	(0.2)	(0.3)	0.2	6.9
2043	7.3	(0.2)	(0.3)	0.2	7.0
2044	7.2	(0.1)	(0.4)	0.2	7.0
2045	7.3	(0.2)	(0.4)	0.3	7.0
2046	7.4	(0.2)	(0.4)	0.3	7.1
2047	7.5	(0.2)	(0.4)	0.3	7.2
2048	7.4	(0.2)	(0.4)	0.3	7.2
2049	7.3	(0.2)	(0.4)	0.3	7.1
2050	7.5	(0.2)	(0.4)	0.4	7.3



# **Hawaiian Electric**

## **Distribution DER Hosting Capacity Grid Needs**

August 2021 Update

# Table of Contents

1.	Introduction.....	6
2.	Total Anticipated DER By Circuit.....	10
2.1.	Aggregate Executed DER .....	10
2.2.	Adjusted DER Growth By Circuit.....	11
2.2.1.	DER Forecast Allocation In LoadSEER .....	12
2.2.2.	DER Forecast Allocation Based on Existing DER .....	13
3.	Analysis.....	15
3.1.	Screen Circuits for Analysis.....	16
3.2.	Hosting Capacity Assessment .....	17
3.3.	Stochastic Hosting Capacity Methodology (PV Grow).....	18
3.4.	Probabilistic Hosting Capacity Methodology.....	18
3.5.	Hosting Capacity Results .....	19
4.	Grid Needs.....	21
5.	Summary and Next Steps .....	26
APPENDIX A: ADJUSTED DER GROWTH BY ISLAND (2021-2025).....		27
	Corporate DER Forecast.....	27
	Adjustments.....	27
	O’ahu .....	27
	Hawai’i Island.....	28
	Maui Island .....	28
	Lana’i.....	29
	Moloka’i.....	29
APPENDIX B: ADJUSTED DER GROWTH BY CIRCUIT (2021 – 2025).....		30
	O’ahu .....	30



Hawai'i Island .....46

Maui Island .....52

Lana'i.....56

Moloka'i.....56

APPENDIX C: HOSTING CAPACITY ANALYSIS RESULTS.....57

Summary.....57

O'ahu .....57

Hawai'i Island.....75

Maui Island .....81

Lana'i.....85

Moloka'i.....86

APPENDIX D: TOTAL DER AND HOSTING CAPACITY BY CIRCUIT .....87

O'ahu .....87

Hawai'i Island.....89

Maui Island .....91

Lana'i.....92

Moloka'i.....93





# Table of Figures

Table 1: Summary of Circuit Selection Screening.....	17
Table 2: Summary of Hosting Capacity Results.....	20
Table 3: Grid Needs Assessment Summary.....	22
Table 4: O’ahu Grid Needs Assessment.....	23
Table 5: Hawaii Island Grid Needs Assessment.....	23
Table 6: Maui Island Grid Needs Assessment.....	24
Table 7: Lanai Grid Needs Assessment.....	24
Table 8: Molokai Grid Needs Assessment.....	25
Table 9: O’ahu Annual DER Forecast (kW).....	27
Table 10: Hawai’i Island Annual DER Forecast (kW).....	28
Table 11: Maui Island Annual DER Forecast (kW).....	28
Table 12: Lana’i Annual DER Forecast (kW).....	29
Table 13: Moloka’i Annual DER Forecast (kW).....	29
Table 14: O’ahu Adjusted DER Growth by Circuit (kW).....	30
Table 15: Hawai’i Island Adjusted DER Growth by Circuit (kW).....	46
Table 16: Maui Island Adjusted DER Growth by Circuit (kW).....	52
Table 17: Lana’i Adjusted DER Growth by Circuit (kW).....	56
Table 18: Moloka’i Adjusted DER Growth by Circuit (kW).....	56
Table 19: O’ahu Hosting Capacity Analysis Results by Circuit.....	57
Table 20: Hawai’i Island Hosting Capacity Analysis Results by Circuit.....	75
Table 21: Maui Island Hosting Capacity Analysis Results by Circuit.....	81
Table 22: Lana’i Hosting Capacity Analysis Results by Circuit.....	85
Table 23: Moloka’i Hosting Capacity Analysis Results by Circuit.....	86
Table 24: O’ahu Total Anticipated DER and Hosting Capacity by Circuit (kW).....	87
Table 25: Hawai’i Island Total Anticipated DER and Hosting Capacity by Circuit (kW).....	89
Table 26: Maui Island Total Anticipated DER and Hosting Capacity by Circuit (kW).....	91
Table 27: Lana’i Total Anticipated DER and Hosting Capacity by Circuit (kW).....	92
Table 28: Moloka’i Total Anticipated DER and Hosting Capacity by Circuit (kW).....	93
Figure 1: Distribution Planning Process and IGP Process.....	6
Figure 2: Stages of the Distribution Planning Process.....	7
Figure 3: Hosting Capacity Grid Needs Identification Stages.....	8
Figure 4: Forecast Stage of the Distribution Planning Process.....	10
Figure 5: Analysis Stage of the Distribution Planning Process.....	15



Figure 6. Summary of Hosting Capacity Analysis .....16  
Figure 7: Summary of Hosting Capacity Results (% of Total Circuits).....20  
Figure 8: Solution Options Stage of the Distribution Planning Process .....21



## 1. INTRODUCTION

As it strives to provide 100 percent renewable energy by 2045, Hawaiian Electric (“Company”) faces a comprehensive transformation of its five electric power grids. Performing the analyses necessary to attain this goal is a complicated resource planning process, requiring new tools and new processes: modeling across generation, transmission, distribution, infrastructure, and behind-the-meter resource options.

The Distribution Planning Process is a current practice employed by the Company to plan the future of the distribution system. This process is incorporated into the Integrated Grid Planning (“IGP”) process as it uses the Corporate Forecasts that include planned electrical demand and distributed energy resources (“DER”) developed through IGP as an input to the distribution planning analyses to identify grid needs. These grid needs (or distribution grid needs) are technical requirements then used as an input into the IGP process which will select portfolios of solutions to address resource, transmission, and distribution requirements. The figure below shows how the Distribution Planning Process (see orange box) is performed in parallel then converges with other identified steps in the IGP Process.

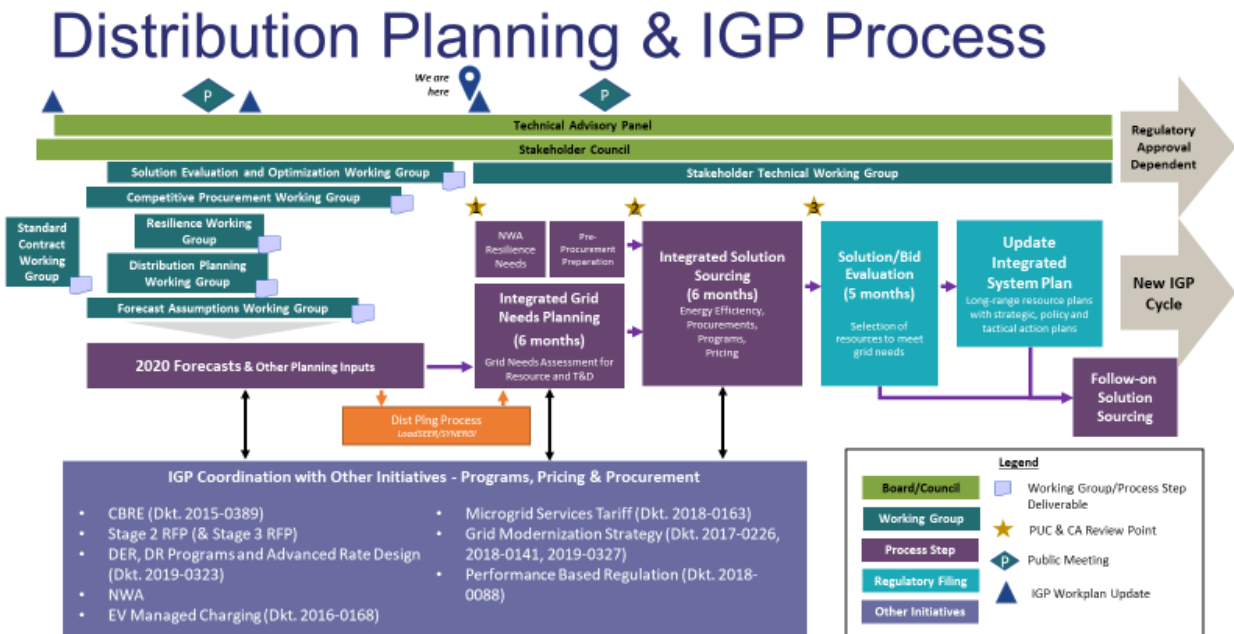

Figure 1: Distribution Planning Process and IGP Process<sup>1</sup>

<sup>1</sup> Hawaiian Electric, Presentation to IGP Stakeholder Technical Working Group, June 17, 2021.



The Distribution Planning Methodology<sup>2</sup> was developed in collaboration with stakeholder and customer engagement through the Distribution Planning Working Group (“DPWG”). The methodology was developed to identify grid needs required to serve load growth and safely interconnect distributed energy resources (“DER”) while maintaining power quality and reliability for all customers.

The Distribution Planning Methodology is comprised of four stages: forecast, analysis, solution options, and evaluation.

1. **Forecast Stage:** Develop circuit-level forecasts based on the corporate demand forecast.
2. **Analysis Stage:** Determine the adequacy of the distribution system.
3. **Solution Options Stage:** Identify the grid needs requirements.
4. **Evaluation Stage:** Evaluation of solutions.

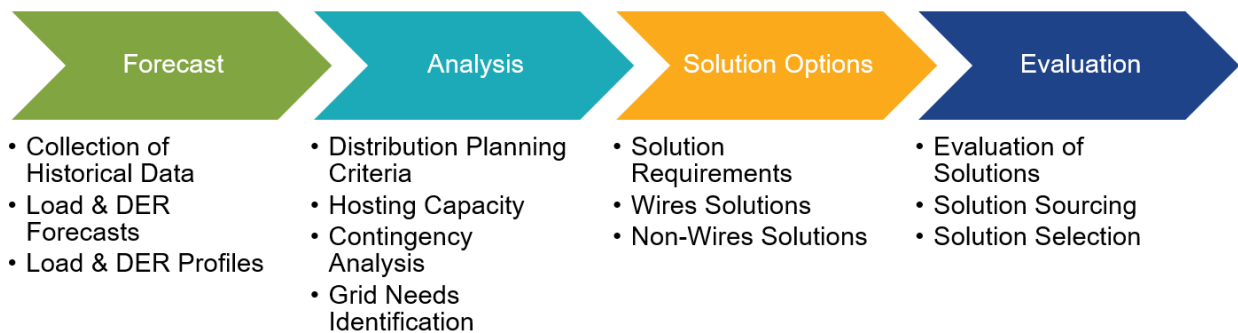

Figure 2: Stages of the Distribution Planning Process

This document focuses on hosting capacity grid needs identified for the next five years (year 2021 through 2025) driven by the forecasted DER growth on distribution circuits based on the market DER forecast provided in the 2020 Integrated Grid Planning Inputs and Assumptions March 2021 Update.<sup>3</sup> As described in the June 2021 Work Plan<sup>4</sup>, the Company anticipates filing a Grid Needs Assessment update deliverable by October 1, 2021 that includes additional modeling and analysis to identify grid needs driven by other DER forecast sensitivities.

Hosting Capacity Grid Needs

The overall process and methodology, using modeling tools such as LoadSEER and Synergi<sup>5</sup>, to develop the grid needs driven by hosting capacity is provided herein. Since this report addresses the hosting capacity grid needs specifically, the distribution planning process figure discussed at

<sup>2</sup> See [https://www.hawaiianelectric.com/documents/clean\\_energy\\_hawaii/integrated\\_grid\\_planning/stakeholder\\_engagement/working\\_groups/distribution\\_planning/20200602\\_dpwg\\_distribution\\_planning\\_methodology.pdf](https://www.hawaiianelectric.com/documents/clean_energy_hawaii/integrated_grid_planning/stakeholder_engagement/working_groups/distribution_planning/20200602_dpwg_distribution_planning_methodology.pdf)

<sup>3</sup> See [https://www.hawaiianelectric.com/documents/clean\\_energy\\_hawaii/integrated\\_grid\\_planning/stakeholder\\_engagement/working\\_groups/forecast\\_assumptions/20210330\\_wg\\_fa\\_deliverable\\_draft.pdf](https://www.hawaiianelectric.com/documents/clean_energy_hawaii/integrated_grid_planning/stakeholder_engagement/working_groups/forecast_assumptions/20210330_wg_fa_deliverable_draft.pdf)

<sup>4</sup> Hawaiian Electric Updated Timeline and Stakeholder Engagement Plan filed on June 18, 2021 in Docket No. 2018-0165 at page 7.

<sup>5</sup> See Hawaiian Electric, Distribution Planning Methodology, June 2020 for an overview of the LoadSEER and Synergi models.

the recent Stakeholder Technical Working Group meeting in June<sup>6</sup> was streamlined to show details related only to this analysis and is shown in Figure 3. Potential wires and non-wires alternative (“NWA”) solutions opportunities using the Non-Wires Opportunity Evaluation Methodology Report<sup>7</sup> will be evaluated later as part of the IGP process.

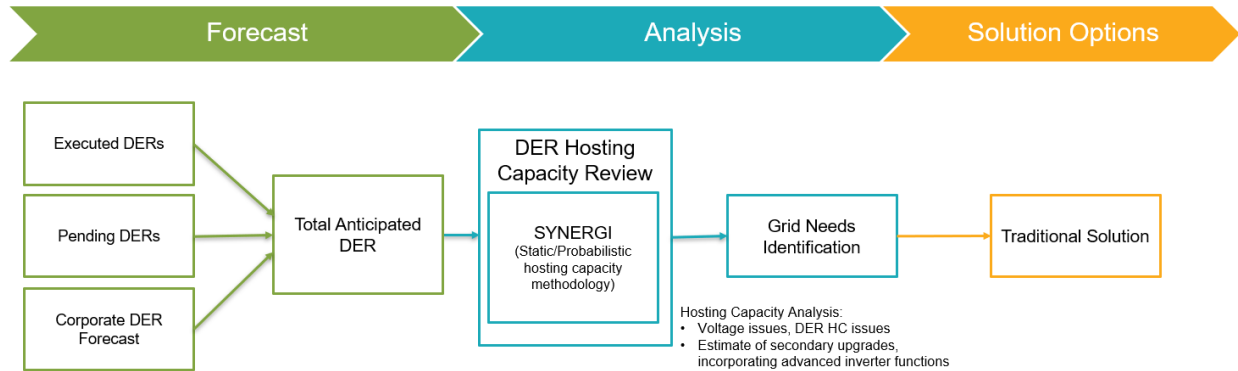

Figure 3: Hosting Capacity Grid Needs Identification Stages

The distribution planning criteria is used to establish circuit-level hosting capacity which is a circuit’s ability to accommodate or host DERs to an identified kilowatt (kW) amount based on steady state load flow analyses. The methodology used to develop these hosting capacity numbers is geared towards analyzing DER growth due to small systems distributed on a circuit. Single large DER interconnections are typically evaluated on a case-by-case basis because their impact on the circuit largely depends on its generating capacity and location. In other words, circuit-level hosting capacity is the maximum aggregate kW amount of small scale DERs a circuit can host before any thermal or voltage violations occur.<sup>8</sup> This hosting capacity kW is utilized to identify the circuits with a grid need when the forecasted DER reaches this identified amount.

The following steps are used to identify circuits with hosting capacity violations in the next five years based on the current market DER forecast:

1. Determine the annual anticipated DER (kW) by circuit.
2. Screen circuits for analysis.
3. Perform circuit-level hosting capacity analysis.

<sup>6</sup> See [https://www.hawaiianelectric.com/documents/clean\\_energy\\_hawaii/integrated\\_grid\\_planning/20210617\\_presentation\\_slides\\_igp\\_stakeholder.pdf](https://www.hawaiianelectric.com/documents/clean_energy_hawaii/integrated_grid_planning/20210617_presentation_slides_igp_stakeholder.pdf) at slide 20.

<sup>7</sup> See [https://www.hawaiianelectric.com/documents/clean\\_energy\\_hawaii/integrated\\_grid\\_planning/stakeholder\\_engagement/working\\_groups/distribution\\_planning/20200602\\_dpwg\\_non\\_wires\\_opportunity\\_evaluation\\_methodology.pdf](https://www.hawaiianelectric.com/documents/clean_energy_hawaii/integrated_grid_planning/stakeholder_engagement/working_groups/distribution_planning/20200602_dpwg_non_wires_opportunity_evaluation_methodology.pdf)

<sup>8</sup> Hawaiian Electric, Distribution Planning Methodology June 2020, at 12.



4. Identify grid needs and solution options.

Throughout the year, Hawaiian Electric reviews and processes DER applications. In accordance with the Initial Technical Review (“ITR”) process outlined in Rule 14H, the hosting capacity screen is one step in the overall interconnection technical review and addresses.



## 2. TOTAL ANTICIPATED DER BY CIRCUIT

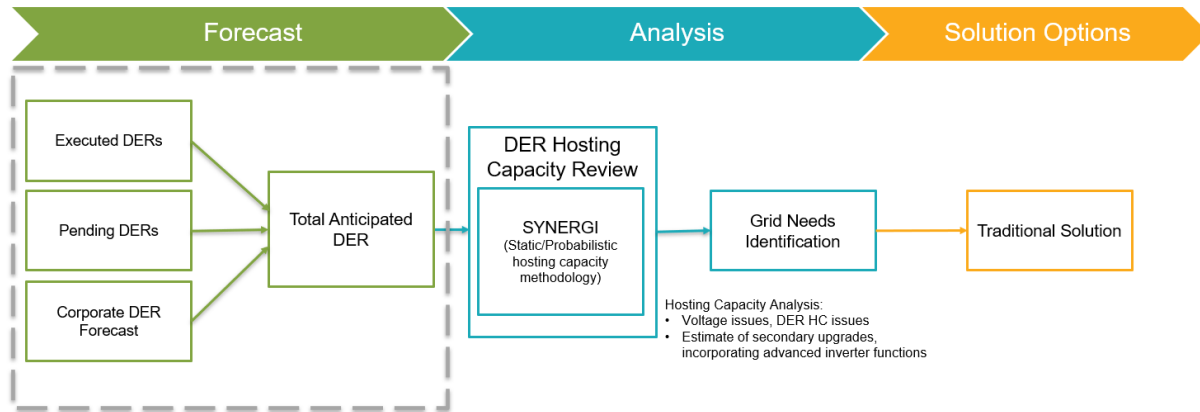

Figure 4: Forecast Stage of the Distribution Planning Process

This section describes the first step used to identify hosting capacity driven distribution grid needs:

1. **Determine the total anticipated DER (kW) by circuit.**
2. Screen circuits for analysis.
3. Perform circuit-level hosting capacity analysis.
4. Identify grid needs and solution options.

The total anticipated DER for a circuit is calculated by adding together the aggregate executed DER on that circuit and the forecasted DER growth for that circuit. The two components of this calculation are explained in the following sections.

$$\text{Total Anticipated DER} = \text{Aggregated Executed DER} + \text{Adjusted DER Growth}$$

### 2.1. AGGREGATE EXECUTED DER

The first step is to identify the existing DER on the circuits. Executed DER at the beginning of the study period is aggregated by total program size (kW) by circuit.<sup>9</sup> The programs included are:

- Net Energy Metering (“NEM”)
- Feed-In Tariff (“FIT”)
- Customer Grid Supply (“CGS”)
- Customer Self-Supply (“CSS”)
- Customer Grid Supply Plus (“GSP”)

<sup>9</sup> Executed programs as of December 31, 2020 are included.



- Smart Export (“ISE”)
- Net Energy Metering Plus (“NEM Plus” or “NMP”)
- Standard Interconnection Agreement (“SIA”)
- Community-Based Renewable Energy (“CBRE”) Phase 1 and Phase 2
- Power Purchase Agreement (“PPA”)

For purposes of this hosting capacity analysis, battery energy storage capacity is not included in the aggregated DER values as it is assumed that energy storage systems will not export during the day.

## 2.2. ADJUSTED DER GROWTH BY CIRCUIT

The corporate demand forecast is provided at the system level, meaning there is one forecast for each island, and is built with separate layers such as underlying load, DER, energy efficiency (“EE”), and electric vehicles (“EV”). To perform the distribution planning hosting capacity analyses that typically occur at the circuit-level, the forecasted DER growth by feeder is determined based on the corporate DER forecast. Adjustments to the forecasted DER growth are made to account for any DER not captured, such as CBRE Phase 2 small projects, and explained in the following sections as well as in Appendix A. The adjusted DER growth is then added to the aggregated executed DER to get the total anticipated DER by circuit used during the hosting capacity assessment in the Analysis stage.

The forecasted DER growth by feeder is derived from the corporate DER forecasts shown in Appendix A using LoadSEER when available. Currently, LoadSEER models are available only for O’ahu with plans for deployment early in year 2022 on the islands of Maui and Hawai’i Island. Since LoadSEER was recently adopted by the Company to create circuit-level forecasts, models for all islands are not fully built or complete to implement LoadSEER for this process. For all other islands, the forecasted DER growth is developed by allocating an island’s corporate DER forecast proportional to the amount of executed DER on each circuit as a percentage of total executed DER on that island. In summary, the forecasted DER growth by year by circuit is determined using one of the following methods:

1. DER forecast allocation in LoadSEER.
2. DER forecast allocation based on existing DER.





Adjustments are also made to the forecasted DER growth by feeder to account for pending known large projects such as CBRE Phase 1, FIT, and large SIA (>250kW) projects. Because size and location of these projects are already known, they are added to the respective circuits in the estimated year of execution to get the adjusted DER growth by feeder shown in Appendix B.

$$\text{Forecasted DER Growth} = \text{Corporate DER Forecast} + \text{Adjustments}^{10}$$

$$\text{Adjusted DER Growth} = \text{Forecasted DER Growth} + \text{Large Project Adjustments}^{11}$$

### 2.2.1. DER FORECAST ALLOCATION IN LOADSEER

LoadSEER is an electric load forecasting software that creates circuit-level forecasts by combining historical SCADA and weather data along with forecasted new load, DER, EV, and EE spatially allocated throughout the system. LoadSEER spatially allocates these layers at the distribution level through an agent-based simulation that determines the likelihood (i.e., propensity score) that each of these types will be adopted at each service point. This process refines the system level forecast and provides location information such as customer consumption, historical DER adoption, census tract data, among others, with circuit-level forecasts. LoadSEER constrains the total amount that gets allocated for each of these layers by an incremental system level limit for each layer. The system level constraint is based on the corporate DER forecast. The resulting DER forecast allocation provides the feeder-level forecasted DER growth that is needed to calculate the adjusted DER forecast and thus the total anticipated DER by feeder.

The corporate DER forecast includes NEM, CGS, CSS, GSP, ISE, NMP, SIA, and a future program. Adjustments are made to the corporate DER forecast to account for the CBRE Phase 2 small projects program as well as pending CBRE Phase 1 and large (>250kW) SIA projects. Anticipating expansion of the CBRE Phase 2 small projects, capacity was increased from 20 MW (15MW for tranche 1 plus 5MW for tranche 2) to 40 MW. This estimate is consistent with the 30 MW small project capacity described in the latest Order.<sup>12</sup> This 40MW of CBRE Phase 2 small projects were included by adding 8 MW per year to the corporate DER forecast. This amount is divided into residential and commercial customer types and is used as the system level DER limit for the spatial allocation in LoadSEER. LoadSEER can consider separate residential and commercial DER profiles when building feeder-level forecasts and this will be important to the Grid Needs Assessment that will be filed in October 2021 however this residential/commercial split was not necessary for this hosting capacity grid needs analysis.

The resulting DER forecast allocation is then adjusted by adding pending CBRE Phase 1 and large SIA projects. Because the project size and location of these pending projects are already known, these adjustments were added to the individual feeder forecasted DER growth to produce the adjusted DER by feeder in Appendix B. The adjusted DER forecast is added to the aggregate

<sup>10</sup> Adjustment for CBRE Phase 2 small projects.

<sup>11</sup> Large project adjustments include CBRE Phase 1, FIT, and large SIA (> 250 kW).

<sup>12</sup> See Order No. 37879 issued on July 27, 2021 in Docket No. 2015-0389, Approving the March 30 CBRE Filings, with Modifications.



executed DER to produce the total anticipated DER, shown in Appendix D, that is used in the Analysis stage.

In summary, the steps to determine the total anticipated DER by circuit by year are:

1. Starting with the corporate DER forecast, add 40 MW for CBRE Phase 2 small projects. (See A and B in Appendix A).
2. Run spatial allocation in LoadSEER to derive the forecasted DER growth by year by circuit.
3. Add pending large projects to construct adjusted DER by year by circuit. (See C in Appendix A).
4. Add aggregate executed DER to get the total anticipated DER.

### 2.2.2. DER FORECAST ALLOCATION BASED ON EXISTING DER

Since LoadSEER models are unavailable for Hawai'i Island and Maui County, a different method for the DER forecast allocation was required. This method involves allocating a system level amount proportional to the amount of executed DER in selected programs<sup>13</sup> on each circuit.

Similar to O'ahu, the corporate DER forecasts for Hawai'i Island and Maui County need to be adjusted for CBRE Phase 2 small projects and pending CBRE Phase 1 and FIT projects to get the system level amounts to allocate. The different CBRE Phase 2 small projects program cap for each island is considered in the calculation of the adjusted DER forecast as shown in Appendix A. The CBRE Phase 2 small projects added are consistent with the capacities described in the latest Order.<sup>14</sup>

The proportional amount that determines the allocation is calculated as the executed DER in selected programs on a feeder as a percentage of the total system executed DER in those same selected programs. The executed FIT and PPA projects are removed from the aggregate executed DER for each feeder as determined above in Section 2.1 to get the amount of executed DER in the selected programs for each feeder. Including only these smaller type programs in this calculation focuses the forecasted DER growth on increasing residential DER systems. The executed FIT and PPA projects were removed because these are typically larger projects that would slant the results of this calculation toward these circuits where small DER may not be as likely to be adopted.

Next, the amount of executed DER in the selected programs on that circuit is expressed as a percentage of the total executed DER in those selected programs on the respective island. The incremental system level DER limit based on the corporate forecast and CBRE Phase 2 small projects is then allocated to the circuit based on this percentage. For example, if the executed DER in the selected programs on a circuit is 5% of the total executed DER on that island, 5% of the adjusted DER forecast will be allocated to that circuit. Pending CBRE Phase 1 and FIT projects are added to the resulting feeder-level forecasted DER growth to get the adjusted DER growth

<sup>13</sup> Selected programs include NEM, CGS, CSS, GSP, ISE, NMP, and SIA.

<sup>14</sup> See Order No. 37879 issued on July 27, 2021 in Docket No. 2015-0389, Approving the March 30 CBRE Filings, with Modifications at page 33.



which is shown in Appendix B. The adjusted DER growth is added to the aggregate executed DER to produce the total anticipated DER, shown in Appendix D, that is used in the Analysis stage.

In summary, the steps to get the total anticipated DER by circuit by year are:

1. Starting with the corporate DER forecast, add CBRE Phase 2 small projects. (See A and B in Appendix A).
2. Determine forecasted DER growth by year by circuit.
  - a. Remove the executed FIT and PPA projects from the aggregate executed DER for each feeder to get the amount of executed DER in the selected programs on each feeder.
  - b. Calculate the executed DER in the selected programs on each circuit as a percentage of total executed DER in those selected programs on that island.

$$\% \text{ Circuit Allocation} = \frac{\textit{Executed DER in selected programs on Circuit}}{\textit{Total Executed DER in selected programs}}$$

- c. Allocate the incremental system level DER limit for each year (year 2021 through 2025) among circuits based on the percentage calculated in the previous step.

$$\text{DER Forecast Allocation} = (\% \textit{ Circuit Allocation}) \times (\textit{incremental system level DER limit})$$

3. Add pending large projects to construct adjusted DER by year by circuit. (See C in Appendix A).
4. Add aggregate executed DER to get the total anticipated DER.



### 3. ANALYSIS

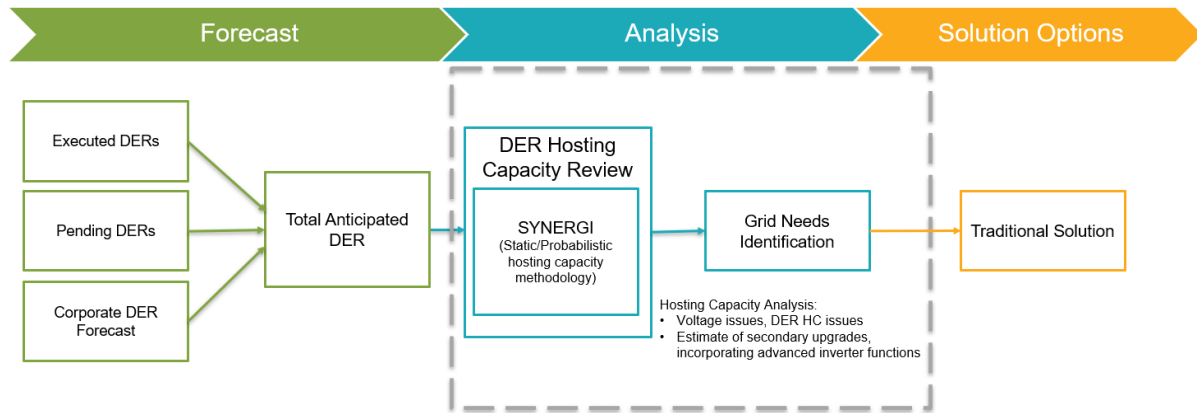

Figure 5. Analysis Stage of the Distribution Planning Process

This section describes steps 2 and 3 used to identify hosting capacity driven distribution grid needs:

1. Determine the annual anticipated DER (kW) by circuit.
2. **Screen circuits for analysis.**
3. **Perform circuit-level hosting capacity analysis.**
4. Identify grid needs and solution options.

A circuit-level hosting capacity assessment is used to determine if a circuit can accommodate the anticipated DER in the study period. A summary of the circuit selection and hosting capacity analysis process is shown in the figure below.



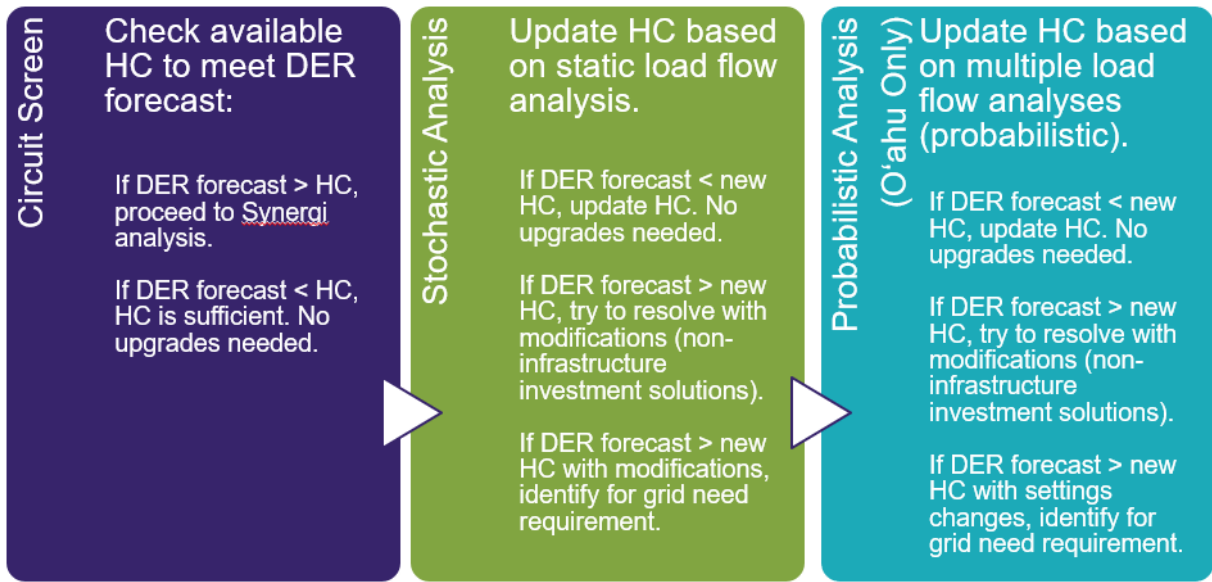

Figure 6. Summary of Hosting Capacity Analysis

### 3.1. SCREEN CIRCUITS FOR ANALYSIS

The Company utilizes a multi-step screening process, which increases in complexity (i.e., time and resources) to further assess the circuit’s ability to host the forecasted DER. Circuits are screened and selected by comparing the anticipated DER by circuit described in Section 2 with the current hosting capacity to determine if the current circuit hosting capacity can accommodate the level of total anticipated DER in the last year of the study period (year 2025). If a circuit is unable to accommodate the anticipated DER in year 2025 with its current hosting capacity, the circuit is selected for further analysis where the hosting capacity is reassessed.

In summary, circuits are selected for further analysis if:

- Total anticipated DER in the year 2025 is greater than the current hosting capacity.

If the total anticipated DER in year 2025 is less than the current hosting capacity, then there are no grid needs and no further analysis is required.

Using this selection screening criteria, a total of 109 circuits are selected for further analysis. A summary of the circuits selected by island is shown in the table below. Company-owned radial distribution circuits are included in the hosting capacity analysis. Dedicated and network (non-radial) circuits are not included in the tables.



Table 1: Summary of Circuit Selection Screening

Island	Total Circuits	Existing Hosting Capacity Satisfies Need (Analysis Not Required)	Total Anticipated DER in 2025 > Hosting Capacity (Analysis Required)
O’ahu	384	341	43
Hawai’i Island	137	99	38
Maui Island	88	65	23
Lana’i	3	1	2
Moloka’i	8	5	3
Total (All Islands)	620	511	109

### 3.2. HOSTING CAPACITY ASSESSMENT

If a circuit is selected for further analysis, the circuit-level hosting capacity is reassessed and updated using one or both of the following methods:

1. Stochastic hosting capacity methodology.
2. Probabilistic hosting capacity methodology.

Both methods use the Synergi load flow software to simulate DER growth to determine the circuit hosting capacity for DER.

A stochastic hosting capacity analysis is done first. This method analyzes specific points in time that envelope the circuit’s characteristics. This method is a much quicker analysis compared to the probabilistic method which is computationally intensive performing the analysis over a variation of DER growth scenarios utilizing time series data. The updated hosting capacity is then compared to the amount of anticipated DER in year 2025. If the revised hosting capacity is greater than the amount of anticipated DER in year 2025, there are no grid needs and no further analysis is required.

If the updated hosting capacity is less than the anticipated DER in year 2025, a subsequent hosting capacity evaluation may be performed using the probabilistic hosting capacity for circuits with available models. If the probabilistic hosting capacity is higher than the anticipated DER in year 2025, the probabilistic hosting capacity will become the updated hosting capacity.

If the stochastic hosting capacity or probabilistic hosting capacity result is less than the anticipated DER in year 2025, the circuit is identified as requiring solution options and further described in Section 3.5.



### 3.3. STOCHASTIC HOSTING CAPACITY METHODOLOGY (PV GROW)

Initially, the hosting capacity is reassessed using Synergi’s built-in PV Grow function. PV Grow stochastically adds PV generators to the selected feeders in proportion to customer load. Generators are added to the feeders until an exception, such as a voltage or thermal violation, occurs. Once an exception is hit, the amount of PV (kW) added plus existing becomes the feeder hosting capacity.

In this analysis, the hosting capacity is determined for a snapshot in time, specifically, the hour representing the daytime minimum load (“DML”) and does not account for the capacity available at other hours which may vary due to load variations throughout the day. To perform this analysis, the following circuit data is input into Synergi:

- Minimum gross demand (kVA and kW) and date and time of occurrence.
- Peak demand (kVA and kW) and date and time of occurrence.

A load flow is simulated in conjunction with the PV Grow analysis to assess daytime minimum load conditions and hosting capacity for the base case. If there are base case violations, such as high and low voltages or thermal overloads, or the hosting capacity is lower than the anticipated DER, then simple mitigation solutions such as modifications to existing equipment (i.e. modifications that do not require infrastructure investments) will be applied and simulated again. These modifications may include substation LTC setting changes, switching, or phase balancing. If a solution option involves substation LTC setting changes then a load flow is also simulated using the peak demand case to verify no violations will occur with the new settings. This process is repeated until a solution option is found that results in no violations in both the DML and peak cases, and hosting capacity accommodates the anticipated DER. The results from the PV Grow analysis is the updated hosting capacity.

If no solution can be found using the PV Grow analysis, then additional analysis may be performed using the probabilistic hosting capacity methodology described below or the circuit is identified as requiring a grid need. Results of the PV Grow analysis are shown in Table 2.

### 3.4. PROBABILISTIC HOSTING CAPACITY METHODOLOGY

The probabilistic hosting capacity is an updated methodology developed in collaboration with the Electric Power Research Institute (“EPRI”) that resulted from discussions with stakeholders to improve the hosting capacity methodology.<sup>15</sup> In contrast to the initial hosting capacity analysis, using the Synergi PV Grow function, that models a single DER growth scenario for a single hour, this updated method models 576 hourly profiles. Probabilistic modeling techniques are applied to

<sup>15</sup> See Hawaiian Electric Companies’ Initial Statement of Position on Deferred Issues and Technical Track Issues issued on August 14, 2017 in Docket No. 2014-0192.



calculate hosting capacity under multiple DER growth scenarios to provide a more robust hosting capacity and is described in further detail in the Distribution Planning Methodology.<sup>16</sup>

The hosting capacity is determined by creating a base case of the circuit model and utilizing circuit-level forecasts generated from LoadSEER, solar irradiance profiles and the scripts developed by EPRI in Synergi to execute the probabilistic hosting capacity analysis. The analysis produces a feeder hosting capacity profile by statistically analyzing feeder exceptions found at different DER penetration levels across multiple DER growth scenarios. Therefore, these results are expected to be a more precise representation of feeder hosting capacity thresholds than results from the PV Grow analysis.

Similar to the stochastic hosting capacity analysis, the probabilistic hosting capacity results are compared to the total anticipated DER in year 2025. If the probabilistic hosting capacity is higher than the anticipated DER, the results become the updated hosting capacity. If the probabilistic hosting capacity is lower than the anticipated DER, simple non-infrastructure investment solutions may be considered and reanalyzed. If the probabilistic hosting capacity is still lower than the anticipated DER, the circuit is identified as requiring a grid need. Results of the probabilistic hosting capacity analysis for O'ahu are combined with the results from Section 3.3 and are shown in Table 2.

### 3.5. HOSTING CAPACITY RESULTS

The hosting capacity analysis results are grouped into the following categories by circuit:

- **Existing Hosting Capacity Satisfies Need:** Existing hosting capacity can accommodate the total anticipated DER in year 2025. No grid needs are required.
- **Updated Hosting Capacity (Without Modifications) Satisfies Need:** Updated hosting capacity can accommodate the total anticipated DER in year 2025. No grid needs are required.
- **Updated Hosting Capacity (With Modifications) Satisfies Need:** Updated hosting capacity along with modifications that do not require infrastructure investments can accommodate the total anticipated DER in year 2025.
- **Solution Option Required:** Updated hosting capacity is unable to accommodate the total anticipated DER in year 2025. Grid need identified.

A summary of the hosting capacity assessment by island is shown below. Of the 620 circuits assessed, 511 circuits are able to accommodate the total anticipated DER in 2025 with the existing hosting capacity. In addition, 65 circuits are able to accommodate the anticipated DER through an updated hosting capacity without grid needs. The remaining 44 circuits are identified as requiring grid needs and are discussed in the following section. The results for O'ahu include

<sup>16</sup> Hawaiian Electric, *Distribution Planning Methodology*, June 2020 at 13-17.





results from both the stochastic and probabilistic analyses. For all other islands, the results are from the PV Grow analysis.

Table 2: Summary of Hosting Capacity Results

Island	Grid Needs Not Required		Grid Needs Required		Total Circuits
	Existing Hosting Capacity Satisfies Need	Updated HC (w/o modifications) Satisfies Need	Updated HC (w/ modifications) Satisfies Need	Solution Option Required	
O'ahu	341	35	5	3	384
Hawai'i Island	99	17	19	2	137
Maui Island	65	13	8	2	88
Lana'i	1	0	0	2	3
Moloka'i	5	0	0	3	8
Total (All Islands)	511	65	32	12	620

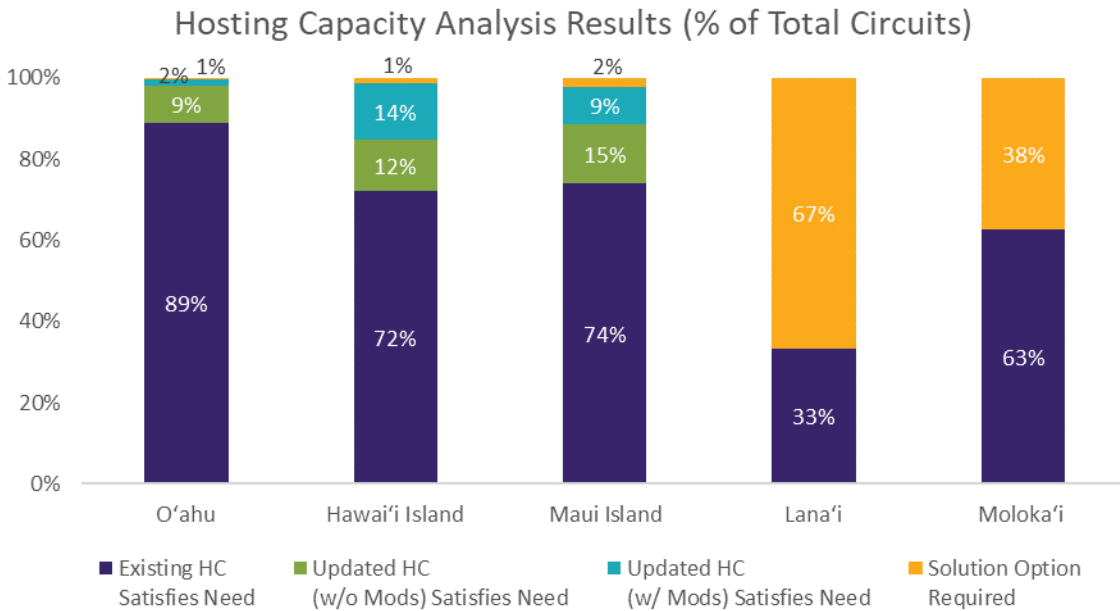

Figure 7: Summary of Hosting Capacity Results (% of Total Circuits)

Hosting capacity results by circuit by island are detailed in Appendix C.



## 4. GRID NEEDS

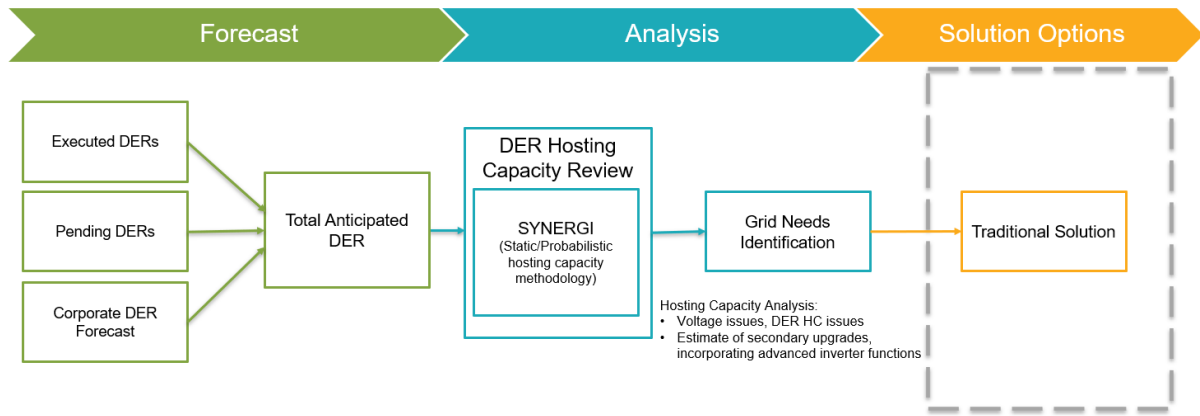

Figure 8: Solution Options Stage of the Distribution Planning Process

This section describes the last step to identify distribution grid needs:

1. Determine the annual anticipated DER (kW) by circuit.
2. Screen circuits for analysis.
3. Perform circuit-level hosting capacity analysis.
4. **Identify grid needs and solution options.**

Grid needs are identified for circuits requiring mitigation resulting from the hosting capacity analysis described in Section 3. A circuit is flagged as requiring mitigation if the hosting capacity is unable to accommodate the anticipated DER in 2025. For these circuits, the annual anticipated DER for each year for the study period (year 2021 through 2025) is compared to the hosting capacity. The earliest year that the anticipated DER is greater than the hosting capacity is identified as the year in which mitigation is required (i.e. operating date). A comparison of the annual anticipated DER to updated hosting capacity by circuit for each island is detailed in Appendix D.

As described in the Distribution Planning Methodology, a traditional solution will be defined for each grid need identified and include:<sup>17</sup>

- **Substation:** Transformer asset identification
- **Circuit:** Feeder asset identification
- **Distribution Service Required:** Hosting Capacity, Distribution Capacity or Distribution Reliability (Back-Tie) Service
- **Primary Driver of Grid Need:** Defines whether the identified grid need is primarily driven by DER growth, demand growth, other factor(s), or a combination of factors

<sup>17</sup> Hawaiian Electric, *Distribution Planning Methodology*, June 2020 at 20.



- **Violation Type:** Thermal and/or voltage violation that triggers the grid need
- **Operating Date:** The date at which traditional infrastructure must be constructed and energized, in advance of the forecasted grid need to maintain safety and reliability
- **Traditional Solution:** Traditional solution identified for mitigation (Solution Options)
- **Cost Estimate:** Estimated cost to provide traditional solution identified.

The following hosting capacity grid needs assessment tables are simplified and do not include all the fields defined above as some are not applicable for the hosting capacity grid needs or the fields are consistent for all islands for all years. The following fields are applicable to all islands and are not replicated in the following tables:

- Distribution Service Required: Increase circuit hosting capacity
- Primary Driver of Grid Need: DER growth

Of the 44 circuits identified as requiring grid needs in Section 3.5, 32 circuits have solution options which can be addressed through modifications to existing equipment. Since these solutions do not require infrastructure investments, the cost to implement is minimal and therefore not shown in the following tables. These modifications include:

- LTC Settings Change: Adjusting the load tap changer (“LTC”) on an existing transformer or regulator

The remaining 12 circuits have solutions requiring infrastructure investments such as:

- Circuit Phase Balancing
- Line regulator installed
- Reconductoring

Table 3: Grid Needs Assessment Summary

Island	Total Circuits	Violation Type <sup>18</sup>		Solution Option	
		Voltage	Conductor Overload	LTC Settings Change	Infrastructure Investments
O’ahu	8	7	2	5	3
Hawai’i Island	21	21	-	19	2
Maui Island	10	10	-	8	2
Lana’i	2	2	-	-	2
Moloka’i	3	3	-	-	3
Total (All Islands)	44	43	2	32	12

<sup>18</sup> Circuit totals by violation type do not match the total circuits column as one circuit on O’ahu has both voltage and conductor overload violations and is counted in both columns.



The grid needs assessment by island by circuit are detailed in the following tables.

### O'ahu

Table 4: O'ahu Grid Needs Assessment

Substation	Circuit	Violation Type	Operating Date	Traditional Solution	Cost Estimate
Kahala	Kilauea 4kv	Voltage, conductor overloading	2025	Circuit phase balancing	\$9,000
Kalama 1	Kainalu	Voltage	2021	Circuit phase balancing and LTC setting change	\$9,000
Kalama 1	Oneawa	Voltage	2025	LTC setting change	-
Kalihi 2	Beckley	Voltage	2022	LTC setting change	-
Makakilo 2	Makakilo 2	Voltage	2025	LTC setting change	-
Piikoi	Piikoi 8	Conductor overloading	2023	Reconductor and increase fuse size	\$270,000
Waialua 3	Kawailoa	Voltage	2021	LTC setting change	-
Waialua 3	Waialua	Voltage	2021	LTC setting change	-

### Hawai'i Island

Table 5: Hawaii Island Grid Needs Assessment

Substation	Circuit	Violation Type	Operating Date	Traditional Solution	Cost Estimate
Halaula	Halaula 1	Voltage	2025	Install two 3ph line regulator	\$431,000
Honokaa	Honokaa 12	Voltage	2023	LTC setting change	-
Honomu	Honomu 1	Voltage	2025	LTC setting change	-
Kauhale	Kauhale 11	Voltage	2021	LTC setting change	-
Kauhale	Kauhale 12	Voltage	2021	LTC setting change	-
Keahole Airport	Keahole Airport 11	Voltage	2025	LTC setting change	-
Komohana	Komohana 12	Voltage	2021	LTC setting change	-
Kurtistown	Kurtistown 12	Voltage	2021	LTC setting change	-
Laupahoehoe	Laupahoehoe 2	Voltage	2023	LTC setting change	-
Namakani Paio	Namakani Paio	Voltage	2021	LTC setting change	-
Ookala	Ookala	Voltage	2021	LTC setting change	-
Orchid Isle	Orchid Isle 11	Voltage	2021	LTC setting change	-
Orchid Isle	Orchid Isle 12	Voltage	2021	LTC setting change	-
Paauilo	Paauilo 1	Voltage	2021	LTC setting change	-



Substation	Circuit	Violation Type	Operating Date	Traditional Solution	Cost Estimate
Palani	Palani 14	Voltage	2021	LTC setting change	-
Panaewa	Panaewa 12	Voltage	2021	LTC setting change	-
Puueo	Puueo 11	Voltage	2021	LTC setting change	-
Puueo	Puueo 12	Voltage	2021	LTC setting change	-
Puuwaawaa	Puuwaawaa 11	Voltage	2021	Install 3ph line regulator	\$216,000
Waikii	Waikii 12	Voltage	2021	LTC setting change	-
Waikoloa	Waikoloa 12	Voltage	2023	LTC setting change	-

### Maui

Table 6: Maui Island Grid Needs Assessment

Substation	Circuit	Violation Type	Operating Date	Traditional Solution	Cost Estimate
Kahului	Kahului 8/4049	Voltage	2021	LTC setting change	-
Kuihelani	Kuihelani 209/1653	Voltage	2021	LTC setting change	-
Kuihelani	Kuihelani 209/1708	Voltage	2021	LTC setting change	-
Lahaina	Lahaina 34/1398	Voltage	2021	Install 3ph line regulator	\$216,000
Paia Mauka	Paia Mauka 93/4042	Voltage	2021	Circuit phase balancing and install 3ph line regulator	\$220,000
Peahi	Peahi 94/1294	Voltage	2021	LTC setting change	-
Pukalani	Pukalani 17/1282	Voltage	2023	LTC setting change	-
Waiinu	Waiinu 36/1493	Voltage	2024	LTC setting change	-
Wailea	Wailea 25/1517	Voltage	2024	LTC setting change	-
Wailea	Wailea 25/1518	Voltage	2024	LTC setting change	-

### Lana'i

Table 7: Lanai Grid Needs Assessment

Substation	Circuit	Violation Type	Operating Date	Traditional Solution	Cost Estimate
Miki Basin	Miki Basin PP 302/1208	Voltage	2025	Install 3ph line regulator	\$259,000
Miki Basin	Miki Basin PP 302/1210	Voltage	2025	Install 3ph line regulator	\$259,000



*Moloka'i*

Table 8: Molokai Grid Needs Assessment

Substation	Circuit	Violation Type	Operating Date	Traditional Solution	Cost Estimate
Palaau	Palaau PP 81/109B	Voltage	2024	Install 3ph line regulator	\$259,000
Palaau	Palaau PP 81/110B	Voltage	2021	Install 3ph line regulator	\$259,000
Palaau	Palaau PP 81/111A	Voltage	2021	Install 3ph line regulator	\$259,000



---

## 5. SUMMARY AND NEXT STEPS

With the use of advanced tools and analysis (e.g., LoadSEER and Synergi), the Company has been able to do a wide-scale update of the available hosting capacity on all primary distribution circuits, as well as determine which circuits require further analysis to accommodate the total anticipated DER in year 2025. As a result of this analysis:

- 576 circuits do not require grid needs:
  - 511 circuits can accommodate the 5-year DER forecast with existing hosting capacity.
  - 65 circuits can accommodate the 5-year DER forecast through updated hosting capacity without modifications.
- 44 circuits require grid needs at the primary distribution circuit-level:
  - 32 circuits can accommodate through minimal investment (e.g., LTC setting changes).
  - 12 circuits require solutions/mitigations, which will serve as an input to the Grid Needs Assessment stage of the IGP process. Total estimated costs for traditional solutions on all islands is \$2.7 M.

Updated hosting capacities and implementation of the above mitigations and solutions will provide an increase of hosting capacity of 16 MW on O‘ahu, 18 MW on Hawai‘i Island, 37 MW on Maui Island, 0.02 MW on Lana‘i, and 0.5 MW on Moloka‘i.

Consistent with the *Non-Wires Opportunity Evaluation Methodology*<sup>19</sup>, cost estimates are developed for solutions that require significant upgrades. These estimates will be used as inputs to the Grid Needs Assessment stage of the IGP process to evaluate if they qualify as an NWA opportunity, and if so, be procured as part of the overarching IGP process where a portfolio of solutions will be selected to address the identified grid needs.

---

<sup>19</sup> Hawaiian Electric, Non-Wires Opportunity Evaluation Methodology June 2020, [https://www.hawaiianelectric.com/documents/clean\\_energy\\_hawaii/integrated\\_grid\\_planning/stakeholder\\_engagement/working\\_groups/distribution\\_planning/20200602\\_dpwg\\_non\\_wires\\_opportunity\\_evaluation\\_methodology.pdf](https://www.hawaiianelectric.com/documents/clean_energy_hawaii/integrated_grid_planning/stakeholder_engagement/working_groups/distribution_planning/20200602_dpwg_non_wires_opportunity_evaluation_methodology.pdf)



# Appendix A: Adjusted DER Growth by Island (2021-2025)

## Corporate DER Forecast

The corporate DER forecast is a key assumption for the grid needs analysis since it is the source to derive the circuit-level DER forecast. This forecast, in combination with the hosting capacity, determines whether a circuit can accommodate the anticipated circuit-level DER growth. The current DER market forecast provided in the 2020 Integrated Grid Planning Inputs and Assumptions March 2021 Update served as the basis to compile the total anticipated DER for the study period shown in Appendix D.

## Adjustments

As described in Section 2.2, the March 2021 Update corporate DER forecast does not consider projects such as CBRE Phase 2 small projects or pending known large projects<sup>20</sup>, so adjustments to the 5-year DER forecast are included to create the forecasted DER growth and adjusted DER growth, respectively. These adjustments are shown in the following tables.

## O’ahu

Table 9: O’ahu Annual DER Forecast (kW)

Year	Adjusted DER Growth <sup>21</sup>			Adjusted DER Growth (Incremental kW)
	Forecasted DER Growth <sup>22</sup>		Adjustment for Large Projects (Cumulative kW)	
	Corporate DER Forecast (Cumulative kW)	Adjustment for CBRE Phase 2 Small Projects (Cumulative kW)		
kW	A	B	C	$D = (A+B+C)_1 - (A+B+C)_0$
2020	534,704	0	0	n/a
2021	565,107	8,000	29,822	68,225
2022	601,702	16,000	35,025	49,798
2023	618,835	24,000	35,025	25,133
2024	636,514	32,000	39,694	30,348
2025	655,712	40,000	39,694	27,198

<sup>20</sup> Large projects include CBRE Phase 1, FIT, and large SIA (> 250 kW).

<sup>21</sup> Adjusted DER Growth = Forecasted Growth + Adjustment for Large Projects

<sup>22</sup> Forecasted DER Growth = Corporate DER Forecast + Adjustment for CBRE Phase 2 Small Projects





## Hawai'i Island

Table 10: Hawai'i Island Annual DER Forecast (kW)

Year	Adjusted DER Growth <sup>21</sup>			Adjusted DER Forecast (Incremental kW)
	Forecasted DER Growth <sup>22</sup>		Adjustment for Large Projects (Cumulative kW)	
	Corporate DER Forecast (Cumulative kW)	Adjustment for CBRE Phase 2 Small Projects (Cumulative kW)		
kW	A	B	C	$D = (A+B+C)_1 - (A+B+C)_0$
2020	110,108	0	0	n/a
2021	118,283	1,500	850	10,525
2022	122,997	3,000	850	6,214
2023	127,691	4,500	850	6,194
2024	131,481	6,000	850	5,290
2025	135,631	7,500	850	5,650

## Maui Island

Table 11: Maui Island Annual DER Forecast (kW)

Year	Adjusted DER Growth <sup>21</sup>			Adjusted DER Forecast (Incremental kW)
	Forecasted DER Growth <sup>22</sup>		Adjustment for Large Projects (Cumulative kW)	
	Corporate DER Forecast (Cumulative kW)	Adjustment for CBRE Phase 2 Small Projects (Cumulative kW)		
kW	A	B	C	$D = (A+B+C)_1 - (A+B+C)_0$
2020	119,232	0	0	n/a
2021	128,567	1,695	1,750	12,779
2022	131,907	3,390	1,750	5,035
2023	136,773	5,085	1,750	6,561
2024	141,221	6,780	1,750	6,143
2025	145,757	8,475	1,750	6,231



## Lana'i

Table 12: Lana'i Annual DER Forecast (kW)

Year	Adjusted DER Growth <sup>21</sup>			Adjusted DER Forecast (Incremental kW)
	Forecasted DER Growth <sup>22</sup>		Adjustment for Large Projects (Cumulative kW)	
	Corporate DER Forecast (Cumulative kW)	Adjustment for CBRE Phase 2 Small Projects (Cumulative kW)		
kW	A	B	C	$D = (A+B+C)_1 - (A+B+C)_0$
2020	833	0	0	n/a
2021	870	0	0	37
2022	877	0	0	7
2023	897	0	0	20
2024	926	0	0	29
2025	1,006	0	0	80

## Moloka'i

Table 13: Moloka'i Annual DER Forecast (kW)

Year	Adjusted DER Growth <sup>21</sup>			Adjusted DER Forecast (Incremental kW)
	Forecasted DER Growth <sup>22</sup>		Adjustment for Large Projects (Cumulative kW)	
	Corporate DER Forecast (Cumulative kW)	Adjustment for CBRE Phase 2 Small Projects (Cumulative kW)		
kW	A	B	C	$D = (A+B+C)_1 - (A+B+C)_0$
2020	2,678	0	0	n/a
2021	2,824	0	250	396
2022	2,896	0	250	72
2023	2,952	0	250	56
2024	3,068	0	250	116
2025	3,112	0	250	44



## Appendix B: Adjusted DER Growth by Circuit (2021 – 2025)

### O’ahu

Table 14: O’ahu Adjusted DER Growth by Circuit (kW)

Circuit	2021	2022	2023	2024	2025
AALA	112.6	237.4	122.3	73.4	95.6
AALAPAPA	98.8	295.7	50.9	69.1	97.1
AHUA	53.7	225.3	117.0	88.3	266.7
AHUI	0.0	0.0	0.0	0.0	0.0
AIEA	76.4	175.2	137.5	57.2	46.8
AIEA 2	76.0	38.1	158.8	43.7	30.0
AIEA 3	71.4	10.8	30.4	9.5	4.8
AINA KOA	55.3	18.5	34.3	61.7	57.4
AINONI	28.3	18.9	5.6	20.1	14.1
AIRPORT	1.0	100.5	7.6	402.7	100.0
AIRPORT 1	0.0	0.0	0.0	0.0	100.0
AIRPORT 2	0.0	1.6	0.0	0.0	0.0
ALA MOANA	0.0	0.0	149.2	0.0	0.0
ALEWA	14.4	16.5	14.6	3.2	7.3
ALIAMANU	230.8	76.3	41.6	52.4	58.5
ANOI	60.0	65.2	44.9	63.4	37.2
ANUU	103.3	145.0	153.6	31.7	127.0
ARCHER 1	100.0	0.0	0.0	0.0	0.0
ARCHER 2	100.0	206.0	0.0	23.8	6.0



Distribution DER Hosting Capacity Grid Needs | August 2021 Update

Circuit	2021	2022	2023	2024	2025
ARCHER 3	650.4	295.5	194.7	38.4	183.5
ARCHER 4	0.0	0.0	100.0	0.0	0.0
AUDITORIUM	218.2	324.5	20.5	46.1	267.0
BARBERS PT	137.4	69.5	143.3	148.4	55.8
BAY DR	8.8	11.8	0.0	21.2	6.3
BEACH LOTS	106.9	289.8	87.2	81.0	47.2
BECKLEY	7.0	103.3	0.0	0.0	1.3
BLACK PT	7.0	8.5	0.0	3.8	4.7
BWS	78.7	300.0	66.4	30.1	271.8
CARLOS LONG	85.9	51.4	34.7	38.1	47.1
CASTNER	272.5	157.9	119.3	52.5	43.0
CEIP 3	1,049.6	39.5	80.8	43.7	66.2
CEIP 4	48.9	29.7	6.4	29.7	30.3
CKT 10	0.0	5.3	120.8	0.0	0.0
CKT 12	0.0	200.0	0.0	0.0	0.0
CKT 16	4,677.4	104.9	109.1	302.8	2.8
CKT 18	122.5	11.9	213.1	116.5	10.4
CKT 6	0.0	39.5	0.0	32.8	19.7
CKT 7	79.9	158.7	264.3	56.1	60.4
CKT 8	0.0	0.0	0.0	0.0	0.0
COCONUT GROVE	40.9	112.1	18.0	10.3	22.7
DAIRYMENS	51.7	36.1	114.3	28.8	81.4
DE RUSSY	12.9	0.0	0.0	0.0	0.0
DEPOT RD	83.8	76.7	42.7	47.7	34.9



Distribution DER Hosting Capacity Grid Needs | August 2021 Update

Circuit	2021	2022	2023	2024	2025
DIAMOND HEAD	36.1	256.8	55.4	305.6	156.0
DOLE 1	100.0	102.8	47.6	0.0	0.0
EKEKELA	13.9	13.5	7.7	6.8	10.0
ENA 1	120.4	53.1	4.8	105.4	19.4
ENA 2	0.0	0.0	7.8	0.0	0.0
ENCHANTED LAKES	99.6	140.0	28.7	142.6	76.8
EWA BEACH 1	308.8	321.2	101.0	344.1	249.1
EWA BEACH 2	382.2	180.4	39.6	93.6	159.4
EWA BEACH 3	240.3	60.8	84.6	64.7	87.7
EWA BEACH 4	360.7	508.4	189.1	208.8	144.7
EWA NUI 1	184.3	182.7	81.5	46.3	101.6
EWA NUI 2	178.4	118.3	34.1	46.7	376.7
FARMERS RD	147.5	39.1	18.5	27.4	52.4
FORT ST	10.8	138.7	1.0	12.0	6.7
FORT ST 1	100.0	0.0	0.0	0.0	100.0
FORT ST 2	103.7	16.7	1.4	4.5	106.1
FORT ST 3	1.2	9.5	6.5	4.9	3.7
FORT ST 4	66.7	219.9	127.0	35.7	81.9
FORT WEAVER 1	354.0	132.1	57.0	61.3	119.8
FORT WEAVER 2	177.8	167.0	99.2	200.2	113.9
FORT WEAVER 3	216.8	253.9	44.5	179.0	138.8
FORT WEAVER 4	189.4	107.1	49.7	69.8	106.4
HAHAIONE	61.0	40.8	20.5	26.1	144.2
HALA 1	517.6	77.0	23.6	28.6	80.3



Distribution DER Hosting Capacity Grid Needs | August 2021 Update

Circuit	2021	2022	2023	2024	2025
HALA 2	63.0	99.6	56.5	96.8	164.1
HALA 3	199.8	380.7	47.4	196.9	82.3
HALA 4	35.7	217.9	121.2	6.1	27.5
HALAWA	67.7	160.0	44.1	74.4	55.6
HALEKOU	108.2	138.8	61.2	74.0	68.5
HANUA 1	0.0	0.0	0.0	0.0	0.0
HANUA 2	0.0	2.3	0.0	0.0	0.0
HAUULA	5,006.6	71.3	45.2	46.0	19.3
HAWN PINE	677.5	55.9	52.9	236.0	131.0
HAWN VILLAGE 1	5.4	1.1	100.0	0.0	8.5
HAWN VILLAGE 2	68.4	56.1	12.7	36.9	44.2
HEEIA	290.7	84.2	67.4	118.2	65.4
HEIGHTS	21.3	25.5	6.0	9.8	27.3
HELEMANO	557.8	150.9	42.8	62.1	42.9
HIGHLANDS	159.8	139.2	161.6	94.0	184.6
HIKINA	10.9	5.3	3.3	3.1	2.0
HILA 1	5.8	10.1	6.1	5.0	102.1
HILA 2	275.8	433.6	11.3	41.2	33.6
HILA 3	139.7	269.5	123.3	85.7	17.7
HILA 4	0.0	0.0	0.0	0.0	0.0
HILA 5	187.3	575.2	42.9	129.8	149.3
HILA 6	0.0	0.0	0.0	0.0	0.0
HOAEAE 1	333.9	308.9	203.0	177.7	475.5
HOAEAE 2	79.7	113.2	208.5	37.6	41.2



Distribution DER Hosting Capacity Grid Needs | August 2021 Update

Circuit	2021	2022	2023	2024	2025
HOAEAE 3	257.2	495.7	112.7	138.5	119.6
HOUGHTAILING	165.6	169.5	35.4	78.6	106.1
HUNAKAI	10.1	18.9	24.4	11.4	21.7
ILANIWAI	19.2	63.4	4.6	103.5	4.1
ILIAINA	45.6	168.5	30.5	23.7	22.6
ILIKAI	63.0	34.1	11.3	20.3	18.1
INDUSTRIAL	240.5	546.2	298.8	170.9	321.4
IWILEI 1 11KV	322.5	373.8	216.9	86.8	94.5
IWILEI 13	152.4	24.2	12.1	9.2	171.0
IWILEI 9	204.7	103.1	100.0	204.7	104.7
KAALAKEI	53.0	202.4	137.3	80.1	104.5
KAENA PT	132.2	76.6	75.7	48.8	260.2
KAHAI	1,314.2	261.0	202.6	263.9	316.2
KAHALA	47.0	29.9	11.5	26.2	32.9
KAHALA 3	4,012.6	144.7	42.7	78.3	118.2
KAHALA MALL	301.1	193.3	126.6	39.0	146.0
KAHALOA	41.7	31.5	7.8	24.3	21.4
KAHE	251.1	292.5	73.0	307.0	247.3
KAHUKU	151.8	156.9	9.5	83.6	159.2
KAI-HARDING	10.3	91.0	2.8	22.7	0.0
KAI-KAIMUKI	14.9	8.6	5.7	9.0	10.0
KAILUA 1	188.0	61.1	44.4	33.8	147.4
KAILUA 2	273.7	301.0	179.1	221.8	114.3
KAILUA HTS	133.3	96.5	55.5	150.6	97.8



Distribution DER Hosting Capacity Grid Needs | August 2021 Update

Circuit	2021	2022	2023	2024	2025
KAINALU	24.3	27.4	116.6	34.6	34.7
KAI-WAIALAE	15.7	21.4	3.1	7.4	21.5
KAI-WILHELMINA	35.0	23.6	138.6	33.0	69.9
KAKAAKO 5	22.7	7.6	28.5	2.6	8.2
KAKAAKO 6	0.0	0.0	0.0	0.0	0.0
KAKAAKO 8	520.0	123.9	206.7	0.0	0.0
KAKAAKO 9	155.6	321.6	128.1	28.8	114.3
KALAHEO	64.0	34.9	9.7	102.2	9.6
KALAHEO 1	100.0	0.0	0.0	0.0	0.0
KALAHEO 2	0.0	0.0	0.0	0.0	0.0
KALAKAUA	108.0	18.4	16.5	14.5	105.8
KALAMA	10.4	243.8	8.4	112.0	23.5
KALIA	0.0	0.0	0.0	0.0	0.0
KALIHI	1.3	2.6	0.0	0.0	0.0
KALIHI KAI	36.4	10.9	19.4	143.2	41.5
KALIHI ST	37.6	25.3	18.1	10.8	27.2
KALIHI UKA	13.0	22.3	11.8	113.9	12.5
KALIHI VALLEY	28.4	12.3	28.5	9.1	25.5
KALOI 1	0.0	100.0	0.0	100.0	0.0
KAM HWY	213.7	282.2	147.6	215.5	84.5
KAM IV	39.1	25.5	16.9	36.5	61.6
KAM TERRACE	52.0	153.2	18.2	27.0	31.7
KAMAKEE	21.8	264.9	4.6	32.9	13.0
KAMANI	2.5	30.3	15.0	15.5	0.0





Distribution DER Hosting Capacity Grid Needs | August 2021 Update

Circuit	2021	2022	2023	2024	2025
KAMOKILA 1	296.6	160.4	172.7	501.0	11.2
KAMOKILA 2	68.4	50.6	42.8	36.7	48.1
KAMOKILA 3	843.0	205.2	298.6	134.5	49.3
KAMOKILA 4	127.7	79.7	46.7	52.5	159.8
KAMOKILA 5	295.1	435.8	253.0	133.0	440.8
KAMOKILA 6	50.5	29.7	14.3	38.8	31.8
KAMOKU 10	334.3	443.4	190.6	217.3	73.3
KAMOKU 9	235.5	335.5	83.7	104.7	71.9
KANAINA	449.4	294.8	255.1	116.6	58.8
KANEKAPOLEI	117.2	25.4	109.7	16.4	18.5
KANEOHE 5	55.9	45.6	31.6	34.0	53.8
KANEOHE 6	268.0	681.7	156.8	407.6	172.4
KAONOHI 1	18.8	28.1	7.8	5.9	160.5
KAONOHI 2	83.3	168.5	40.2	43.8	39.6
KAONOHI 3	107.2	111.5	32.3	35.1	74.4
KAONOHI 4	31.7	15.1	11.1	13.4	26.4
KAPAHULU 1	5.4	106.3	2.7	6.3	4.5
KAPAHULU 2	0.0	0.0	0.0	0.0	0.0
KAPAHULU 3	0.0	105.9	105.9	0.0	0.0
KAPAHULU 4	28.0	115.1	31.8	41.8	5.8
KAPALAMA	14.8	22.5	9.5	7.7	12.3
KAP-HARDING	29.3	15.0	19.3	13.0	24.1
KAPIOLANI 1	245.6	264.5	75.8	124.7	78.1
KAPIOLANI 2	214.8	361.0	169.3	245.2	168.2



Distribution DER Hosting Capacity Grid Needs | August 2021 Update

Circuit	2021	2022	2023	2024	2025
KAPIOLANI 3	55.5	280.8	46.9	130.7	175.5
KAP-KAIMUKI	6.2	2.0	1.5	0.0	2.7
KAPOLEI 1	0.0	100.0	0.0	0.0	0.0
KAPOLEI 2	230.0	132.0	70.2	80.0	83.3
KAPOLEI 3	237.4	162.1	24.1	122.1	38.0
KAPOLEI 4	5,068.1	71.4	26.6	33.5	28.8
KAP-WAIALAE	12.5	133.3	106.4	8.5	29.6
KAUHALE	491.1	346.9	275.9	136.4	158.3
KAWAIOA	138.1	93.1	54.4	101.0	55.8
KAWELA	154.8	131.3	120.9	25.7	236.8
KEALAOLU	50.5	2.0	11.5	16.4	8.6
KEAWE	118.4	15.6	11.2	105.3	111.1
KEEHI 1	0.0	34.1	17.1	0.0	17.1
KEEHI 5	96.3	240.8	100.0	94.5	48.1
KEEHI 6	126.7	111.1	290.1	113.6	48.0
KEEHI 7	263.0	0.0	200.0	0.0	0.0
KEEHI 8	0.0	111.5	300.0	0.0	0.0
KEOLU DR	127.0	52.2	164.6	60.2	97.0
KEWALO	86.4	73.4	41.5	4,825.5	56.8
KEWALO 1	52.9	87.3	56.5	36.4	153.4
KEWALO 2	23.5	16.7	5.1	163.2	168.9
KEWALO 3	0.0	44.3	0.0	0.0	0.0
KEWALO 4	10.1	17.0	4.0	105.0	19.5
KEWALO 5	229.9	245.3	25.8	105.1	147.4



Distribution DER Hosting Capacity Grid Needs | August 2021 Update

Circuit	2021	2022	2023	2024	2025
KEWALO 6	23.4	300.0	0.0	0.0	100.0
KEWALO 7	0.0	200.0	100.0	0.0	100.0
KILAUEA 12KV	39.4	230.8	28.2	40.1	111.2
KILAUEA 4KV	25.0	22.8	12.9	15.1	7.7
KIPAPA	376.8	519.0	107.0	24.2	113.8
KO OLINA 1	47.2	70.0	25.8	2.5	103.1
KO OLINA 2	0.0	0.0	23.7	0.0	0.0
KO OLINA 3	0.0	0.0	0.0	0.0	0.0
KOKOHEAD	55.7	51.1	8.7	20.7	66.5
KOLOA	33.7	6.2	5.2	33.1	26.3
KONA ST	0.0	0.0	0.0	100.0	0.0
KUAHELANI 1	82.8	141.4	38.0	51.4	71.8
KUAHELANI 2	163.9	27.1	188.0	32.2	16.6
KUAHELANI 3	80.9	80.3	53.7	54.6	38.9
KUAHELANI 4	112.5	103.8	52.7	66.2	92.5
KUAKINI	12.9	9.7	8.3	6.9	4.8
KUAPA 1	229.2	118.9	40.8	59.7	47.0
KUAPA 2	50.8	157.4	19.3	25.6	99.5
KUAPA 3	64.4	153.0	32.8	49.3	51.6
KUAPA 4	162.2	147.3	18.9	23.9	50.5
KUHIO	104.5	22.7	44.3	1.9	1.0
KUHIO 1	11.8	17.2	7.2	3.9	10.8
KUHIO 2	100.0	100.0	0.0	100.0	0.0
KUHIO 3	0.0	0.0	0.0	0.0	0.0



Distribution DER Hosting Capacity Grid Needs | August 2021 Update

Circuit	2021	2022	2023	2024	2025
KUHIO 4	47.8	150.8	140.4	26.1	52.9
KUILIMA 1	49.3	50.0	66.0	43.2	89.8
KUNIA	13.4	105.7	102.7	60.8	1.4
KUNIA MAKAI 1	96.3	51.9	42.7	44.5	32.6
KUNIA MAKAI 2	132.7	122.9	380.9	188.1	64.8
KUNIA MAKAI 3	219.9	51.5	150.7	53.8	59.1
KUNIA MAKAI 4	47.9	43.0	18.0	26.5	33.6
LAGOON	0.0	104.0	0.0	100.0	0.0
LAKESIDE 1	38.3	29.2	13.2	218.3	22.8
LAKESIDE 2	33.7	125.6	14.9	21.9	24.3
LAKESIDE 3	73.0	294.3	26.7	39.1	34.0
LAKESIDE 4	200.6	62.9	49.2	65.6	174.1
LANIKAI	56.0	6.3	7.2	0.0	3.9
LAULIMA	62.8	150.8	23.3	134.2	41.3
LEAHI	92.9	187.2	68.6	108.2	78.2
LEOMELE	98.7	110.5	48.0	23.3	61.5
LEOOLE	375.0	580.5	260.2	299.9	173.8
LIBERTY HOUSE	19.9	0.0	19.9	19.9	19.9
LIGHTHOUSE	11.0	156.0	145.4	52.5	2.7
LIKELIKE	25.6	20.6	6.6	2.9	17.7
LILIHA MAKAI	7.3	1.1	3.6	5.7	138.6
LOWREY	28.2	91.9	17.8	17.8	19.9
LUAWAI	490.3	114.5	94.1	40.3	217.2
LUMIAUUAU	72.1	168.4	85.4	52.7	160.3



Distribution DER Hosting Capacity Grid Needs | August 2021 Update

Circuit	2021	2022	2023	2024	2025
MACHADO ST	22.8	110.9	5.6	8.3	17.9
MAHUKONA	106.3	29.7	3.7	51.0	5.8
MAKAHA	473.3	183.9	163.8	72.8	210.6
MAKAHA VALLEY	17.2	18.6	8.8	106.3	21.2
MAKAKILO 1	115.7	76.7	132.8	60.0	78.0
MAKAKILO 2	314.7	3,356.0	64.1	87.0	228.6
MAKAKILO 3	98.6	52.0	34.6	33.7	75.2
MAKAKILO 4	19.8	12.4	15.8	25.7	27.7
MAKALAPA-MOANALUA	103.5	138.1	33.4	243.6	60.9
MAKALOA	110.6	8.2	26.6	48.9	8.9
MALAKOLE	0.0	0.0	0.0	0.0	0.0
MALAKOLE 4	294.9	2,256.3	51.0	433.8	240.5
MANAGERS	31.4	27.8	17.3	30.8	27.5
MANOA 1	56.1	32.0	22.0	9.9	19.8
MANOA 2	35.0	135.7	20.9	16.4	120.7
MANOA 3	165.6	263.1	195.2	147.6	72.0
MANOA 4	0.0	0.0	0.0	0.0	0.0
MANOA-MCCULLY	58.6	166.1	31.5	8.4	8.4
MANOA-PIIKOI	196.4	45.6	40.5	41.7	55.8
MAPUNAPUNA	48.5	75.4	6.8	41.1	96.3
MAPUNAPUNA-MOANALUA	7.9	117.3	14.9	15.9	25.2
MAUKA	284.3	425.2	451.0	615.1	510.1
MAUNALANI	34.3	115.7	112.1	18.5	16.9
MAUNAWILI	0.0	0.0	0.0	0.0	0.0



Distribution DER Hosting Capacity Grid Needs | August 2021 Update

Circuit	2021	2022	2023	2024	2025
MCCULLY 1	65.8	192.1	86.3	157.3	88.7
MCCULLY 3	234.2	171.3	223.1	65.0	124.2
MCCULLY 5	104.8	208.5	51.0	102.0	34.8
MIKILUA 1	66.8	126.0	41.2	184.4	58.8
MIKILUA 3	227.9	222.6	213.3	380.2	147.8
MIKILUA 4	447.7	253.7	45.9	21.4	245.9
MIKILUA 5	307.5	248.7	140.1	141.4	160.8
MILILANI 1	70.8	33.8	33.6	41.8	75.9
MILILANI 2	80.2	72.7	38.6	58.6	64.0
MILILANI 3	37.0	37.3	59.4	30.1	100.0
MILILANI 4	264.4	144.4	146.5	82.9	99.1
MOILILI 1	159.3	132.6	25.9	32.0	29.2
MOILILI 2	109.9	185.3	102.5	135.0	107.3
MOKAUEA	80.6	59.9	115.7	154.2	52.3
MOKUOLA	566.1	505.2	322.0	268.8	101.6
MOKUONE 1	0.0	100.0	0.0	0.0	0.0
MOKUONE 2	29.6	248.9	25.1	133.0	53.3
NIU	104.2	39.9	41.7	49.3	165.0
NUMANA	10.8	13.8	11.4	21.3	22.0
NUUANU	23.2	13.8	120.4	19.7	51.9
NUUANU 2	57.1	31.9	31.1	13.3	24.4
NUUANU 3	82.7	26.7	24.1	48.5	178.2
Ocean Pointe 1	163.0	258.1	122.9	122.0	100.9
OCEAN POINTE 2	162.2	115.4	32.2	71.8	55.2



Distribution DER Hosting Capacity Grid Needs | August 2021 Update

Circuit	2021	2022	2023	2024	2025
OCEAN POINTE 3	113.2	113.1	82.8	61.8	41.0
OCEAN POINTE 4	55.9	37.2	37.9	22.4	25.8
OLOMANA	933.9	8.2	3.8	9.3	25.4
ONEAWA	26.2	15.9	8.7	16.3	11.3
PAHIA	334.1	187.6	40.3	53.7	158.5
PAIWA	175.5	175.7	30.2	32.9	198.4
PALEKA	46.4	51.3	33.1	36.5	55.4
PALI	181.4	103.4	46.7	33.6	66.4
PAOAKALANI	218.0	112.3	3.1	2.4	8.9
PAUOA 1	61.7	39.5	26.4	30.7	20.4
PAUOA 2	350.2	156.7	73.3	112.8	92.5
PAWAA KAI	211.9	38.0	304.0	0.0	28.4
PAWAINA	16.3	25.2	20.1	17.4	21.6
PEARL CITY 1	174.9	259.4	194.4	67.2	128.4
PEARL CITY 2	354.1	192.6	392.8	250.0	345.2
PENINSULA	35.4	267.8	18.5	261.2	142.4
PENSACOLA	142.9	72.0	17.8	68.8	260.4
PIIKOI	70.5	64.1	51.7	27.0	38.5
PIIKOI 7	129.8	12.9	29.9	27.6	8.1
PIIKOI 8	173.9	194.1	158.3	40.4	46.1
POAMOHO	0.0	0.0	0.0	0.0	0.0
POHAKUPU 4	60.2	34.2	23.3	32.9	46.9
PORTLOCK	193.7	408.9	36.1	162.6	68.0
PUNALUU	80.6	303.8	34.8	54.9	162.3



Distribution DER Hosting Capacity Grid Needs | August 2021 Update

Circuit	2021	2022	2023	2024	2025
PUNCHBOWL	54.2	10.6	38.4	2.9	12.0
PUOHALA 1	175.6	62.6	26.4	49.0	72.1
PUOHALA 2	187.5	149.8	107.9	113.3	188.7
PUUHALE	158.1	92.9	122.2	12.6	54.9
PUUNUI	18.2	13.6	12.6	5.9	14.5
QUEEN ST	139.1	35.2	6.2	5.4	0.0
QUEENS 1	63.9	48.0	29.4	19.4	30.1
QUEENS 2	142.6	23.6	16.7	21.9	15.4
RUGER	15.8	10.4	1.6	9.4	8.3
SAND ISLAND	151.9	64.4	79.3	45.9	13.7
SAND ISLAND 1	100.0	0.9	100.0	0.0	38.7
SAND ISLAND 2	363.0	100.0	0.0	19.9	0.0
SCHOOL ST	123.6	92.2	193.4	90.0	100.3
SCHOOL ST 3	32.5	232.7	20.7	124.6	225.2
SHAFTER	100.0	215.6	4.3	106.1	0.0
SHERATON 1	10.8	10.8	4.7	11.2	5.3
SHERATON 2	30.5	12.8	20.2	1.8	15.6
SHOPPING CTR	19.9	150.8	27.7	27.7	83.2
SOUTH RAMP 1	474.8	297.2	73.9	28.8	3.5
ST LOUIS	67.3	57.4	159.0	35.6	62.1
ST LOUIS HTS	8.5	1.3	0.0	0.0	3.8
THURSTON	71.2	68.7	68.4	116.1	37.6
TOWN	0.8	1.6	0.0	0.8	0.8
UALENA	6.2	30.1	58.0	114.7	22.1





Distribution DER Hosting Capacity Grid Needs | August 2021 Update

Circuit	2021	2022	2023	2024	2025
UPLANDS	137.1	9.8	6.6	16.0	114.3
UWAPO 1	125.9	69.6	64.4	84.8	86.3
UWAPO 2	37.0	11.8	11.3	7.7	16.5
UWAPO 3	90.7	175.3	35.6	57.9	57.0
UWAPO 4	58.2	0.0	3.4	0.0	29.1
WAHIAWA HTS	117.1	187.8	157.0	158.5	83.2
WAHIAWA PROPER	57.0	60.4	50.2	70.7	140.8
WAIKAMILO 1	0.0	12.1	125.7	21.1	11.8
WAIKAMILO 2	97.7	162.5	60.2	92.3	156.4
WAIKAMILO 3	204.2	149.6	156.6	33.6	60.8
WAIKAMILO 4	134.2	279.0	153.1	57.1	56.3
WAIKAMILO-IWILEI	10.4	24.3	10.0	14.2	21.3
WAIKAMILO-KAPALAMA	92.7	349.0	182.7	192.9	242.4
WAIALAE NUI	37.2	231.8	107.9	14.6	34.6
WAIALAE SC	0.0	0.0	0.0	0.0	0.0
WAIALUA	91.5	167.6	121.1	53.8	45.5
WAIAWA 1	954.4	104.2	162.1	182.1	59.5
WAIAWA 2	1,275.6	77.8	15.1	149.7	119.0
WAIAWA 3	140.9	114.5	17.2	13.1	13.5
WAIAWA 4	197.5	106.9	260.5	38.6	80.7
WAIHEE 1	176.8	172.9	182.6	136.1	46.0
WAIHEE 2	85.3	93.5	55.4	27.9	86.4
WAIHEE 3	10.0	18.9	10.5	11.5	125.3
WAIHEE 4	113.9	129.0	69.8	58.9	201.7



Distribution DER Hosting Capacity Grid Needs | August 2021 Update

Circuit	2021	2022	2023	2024	2025
WAIKELE CTR	31.5	31.5	18.3	118.3	0.0
WAIKIKI 1	29.4	21.2	102.3	22.8	18.8
WAIKIKI 2	18.3	18.3	0.0	118.3	18.3
WAIKIKI 3	57.5	39.8	279.1	141.2	85.3
WAIKIKI 4	2.3	102.6	2.4	4.8	5.8
WAIKIKI 5	76.7	28.3	114.8	10.6	19.9
WAIKIKI 6	55.4	227.7	55.4	0.0	55.4
WAILANI	20.6	64.2	37.0	45.5	6.4
WAILUPE	109.9	120.5	180.0	177.8	188.0
WAIMALU 1	1,907.2	244.3	18.8	27.0	21.2
WAIMALU 2	141.4	171.9	69.1	51.3	165.7
WAIMALU 3	153.7	140.9	77.8	72.9	64.1
WAIMALU 4	162.2	165.9	41.0	164.3	124.0
WAIMANALO	172.5	212.5	41.2	176.9	53.5
WAIMANO 5	81.6	33.8	39.2	22.2	29.2
WAIMANO 6	67.1	181.1	231.4	18.6	226.5
WAIMANO HOME RD	135.7	111.0	54.0	82.7	105.1
WAIMEA 1	130.8	10.2	19.6	3.5	31.9
WAIMEA 2	203.8	237.1	19.6	29.9	58.4
WAIOMAO	111.8	96.1	47.9	63.0	247.1
WAIPAHU	328.2	510.9	271.8	254.8	240.6
WAIPIO 1	262.4	52.2	39.2	155.4	125.7
WAIPIO 2	141.6	297.7	44.1	214.9	134.6
WAIWAI	100.0	62.6	200.0	0.0	155.2



Circuit	2021	2022	2023	2024	2025
WAI-WILHELMINA	10.5	17.2	9.7	13.8	31.3
WHITMORE	1.9	0.0	0.0	0.0	4.4
WILIWILI	50.7	25.4	24.5	25.1	23.5
WILIWILI 2	41.9	27.2	3.6	14.0	19.9
WOODLAWN	15.3	25.8	0.0	13.8	19.1

## Hawai'i Island

Table 15: Hawai'i Island Adjusted DER Growth by Circuit (kW)

Circuit	2021	2022	2023	2024	2025
Ainaloa 11	60.5	38.8	38.7	33.1	35.3
Ainaloa 12	42.6	27.3	27.2	23.3	24.8
Anaehoomalu 11	15.2	9.8	9.7	8.3	8.9
Anaehoomalu 12	25.9	16.7	16.6	14.2	15.1
Anaehoomalu 13	18.5	11.9	11.8	10.1	10.8
Captain Cook 11	127.4	81.8	81.6	69.7	74.4
Captain Cook 12	97.4	62.5	62.3	53.2	56.9
Hakalau 1	14.0	9.0	9.0	7.7	8.2
Halaula 1	51.0	32.7	32.6	27.9	29.8
Halaula 2	0.0	0.0	0.0	0.0	0.0
Hale Pohaku 11	20.2	13.0	13.0	11.1	11.8
Hale Pohaku 12	8.5	5.5	5.5	4.7	5.0
Haleaha 11	41.2	26.4	26.4	22.5	24.0
Haleaha 12	127.7	82.0	81.7	69.8	74.6
Hawaiian Beaches 11	65.0	41.7	41.6	35.5	37.9



Distribution DER Hosting Capacity Grid Needs | August 2021 Update

Circuit	2021	2022	2023	2024	2025
Hawaiian Beaches 12	0.5	0.3	0.3	0.3	0.3
Hawaiian Paradise Park 11	61.0	39.2	39.0	33.3	35.6
Hawaiian Paradise Park 12	118.3	75.9	75.7	64.7	69.1
Hawaiian Paradise Park 13	311.7	200.2	199.5	170.4	182.0
Hawaiian Paradise Park 14	53.0	34.0	33.9	29.0	30.9
Hawi 11	41.6	26.7	26.6	22.8	24.3
Hawi 12	32.3	20.7	20.7	17.7	18.9
Honokaa 12	48.4	31.0	30.9	26.4	28.2
Honokaa 14	64.7	41.6	41.4	35.4	37.8
Honomu 1	18.9	12.2	12.1	10.3	11.1
Host Park 11	82.1	52.7	52.6	44.9	48.0
Host Park 12	0.0	0.0	0.0	0.0	0.0
Host Park 13	6.9	4.4	4.4	3.8	4.0
Host Park 14	43.5	28.0	27.9	23.8	25.4
Huehue 11	478.6	307.3	306.3	261.6	279.4
Kahaluu 11	160.0	102.8	102.4	87.5	93.4
Kahaluu 12	90.3	58.0	57.8	49.4	52.7
Kahaluu 14	22.4	14.4	14.3	12.3	13.1
Kahaluu 15	145.9	93.7	93.4	79.8	85.2
Kailua 11	191.4	122.9	122.5	104.6	111.7
Kailua 12	2.7	1.7	1.7	1.5	1.6
Kailua 15	256.2	164.5	164.0	140.1	149.6
Kaloko 11	130.8	84.0	83.7	71.5	76.4
Kaloko 12	25.2	16.2	16.2	13.8	14.7



Distribution DER Hosting Capacity Grid Needs | August 2021 Update

Circuit	2021	2022	2023	2024	2025
Kaloko 13	85.4	54.9	54.7	46.7	49.9
Kaloko 14	3.7	2.4	2.4	2.0	2.1
Kamuela 11	3.0	1.9	1.9	1.6	1.8
Kamuela 12	97.0	62.3	62.1	53.0	56.6
Kanoelehua 11	58.4	37.5	37.4	31.9	34.1
Kanoelehua 1101	62.9	40.4	40.3	34.4	36.7
Kanoelehua 12	49.2	31.6	31.5	26.9	28.7
Kanoelehua 13	8.3	5.3	5.3	4.5	4.8
Kanoelehua 14	94.1	60.4	60.2	51.4	54.9
Kanoelehua 1401	87.1	55.9	55.8	47.6	50.9
Kanoelehua 15	111.1	71.4	71.1	60.7	64.9
Kanoelehua 17	37.2	23.9	23.8	20.4	21.7
Kapua 11	21.4	13.8	13.7	11.7	12.5
Kapua 12	57.5	36.9	36.8	31.4	33.6
Kauhale 11	73.6	47.3	47.1	40.2	43.0
Kauhale 12	12.7	8.2	8.2	7.0	7.4
Kaumana 11	187.5	120.4	120.0	102.5	109.5
Kaumana 12	54.3	34.8	34.7	29.7	31.7
Kawaihae 11	17.4	11.2	11.2	9.5	10.2
Kawaihae 12	30.5	19.6	19.5	16.7	17.8
Kawaihae 13	1.5	1.0	0.9	0.8	0.9
Kawailani 11	161.4	103.6	103.3	88.2	94.2
Kawailani 12	154.2	99.0	98.7	84.3	90.0
Keahole Airport 11	86.4	55.5	55.3	47.2	50.4



Distribution DER Hosting Capacity Grid Needs | August 2021 Update

Circuit	2021	2022	2023	2024	2025
Keahole Airport 12	24.1	15.5	15.4	13.2	14.1
Keahole Airport 13	54.9	35.2	35.1	30.0	32.1
Keahuolu 11	16.7	10.7	10.7	9.1	9.8
Keahuolu 12	44.6	28.7	28.6	24.4	26.1
Kealakehe 11	52.1	33.4	33.3	28.5	30.4
Kealia 11	23.1	14.8	14.8	12.6	13.5
Kealia 12	38.7	24.9	24.8	21.2	22.6
Keauhou 11	84.9	54.5	54.4	46.4	49.6
Keauhou 13	94.5	60.7	60.5	51.7	55.2
Komohana 12	251.6	161.6	161.1	137.6	146.9
Komohana 13	228.8	146.9	146.4	125.1	133.6
Komohana 14	17.6	11.3	11.3	9.6	10.3
Kuakini 11	302.5	194.2	193.6	165.4	176.6
Kuakini 13	71.9	46.2	46.0	39.3	42.0
Kuakini 14	299.0	192.0	191.4	163.4	174.6
Kulani 12	2.5	1.6	1.6	1.4	1.4
Kurtistown 12	72.6	46.6	46.5	39.7	42.4
Lalamilo 11	56.4	36.2	36.1	30.8	32.9
Lalamilo 12	20.9	13.4	13.4	11.4	12.2
Laupahoehoe 1	6.9	4.4	4.4	3.8	4.0
Laupahoehoe 2	14.6	9.4	9.3	8.0	8.5
Maliu Ridge 11	26.6	17.1	17.0	14.5	15.5
Maliu Ridge 12	33.2	21.3	21.3	18.2	19.4
Mauna Lani 11	189.0	121.4	121.0	103.3	110.4



Distribution DER Hosting Capacity Grid Needs | August 2021 Update

Circuit	2021	2022	2023	2024	2025
Mauna Lani 13	65.9	42.3	42.2	36.0	38.5
Mauna Lani 14	287.3	184.5	183.9	157.1	167.8
Mountain View 11	76.8	49.3	49.2	42.0	44.8
Mountain View 12	14.7	9.4	9.4	8.0	8.6
Namakani Paio	14.6	9.4	9.3	8.0	8.5
Ookala	13.0	8.4	8.3	7.1	7.6
Orchid Isle 11	4.7	3.0	3.0	2.6	2.7
Orchid Isle 12	26.7	17.1	17.1	14.6	15.6
Ouli 11	40.8	26.2	26.1	22.3	23.8
Ouli 12	76.7	49.3	49.1	41.9	44.8
Paauiilo 1	19.0	12.2	12.1	10.4	11.1
Pahala 11	27.2	17.5	17.4	14.9	15.9
Pahala 12	5.4	3.5	3.5	3.0	3.2
Palani 11	7.4	4.8	4.8	4.1	4.3
Palani 12	157.5	101.2	100.8	86.1	92.0
Palani 13	0.0	0.0	0.0	0.0	0.0
Palani 14	53.7	34.5	34.4	29.4	31.4
Panaewa 11	84.9	54.5	54.3	46.4	49.6
Panaewa 12	150.6	96.7	96.4	82.3	88.0
Papaalooa 1	13.0	8.3	8.3	7.1	7.6
Papaalooa 2	8.5	5.4	5.4	4.6	4.9
Poopoomino 11	120.2	77.2	76.9	65.7	70.2
Poopoomino 12	61.5	39.5	39.4	33.6	35.9
Poopoomino 13	47.3	30.4	30.3	25.8	27.6



Distribution DER Hosting Capacity Grid Needs | August 2021 Update

Circuit	2021	2022	2023	2024	2025
Poopoomino 14	114.9	73.8	73.6	62.8	67.1
Punaluu 11	1.1	0.7	0.7	0.6	0.7
Punaluu 12	12.3	7.9	7.9	6.7	7.2
Puueo 11	98.2	63.1	62.9	53.7	57.4
Puueo 12	101.0	64.8	64.6	55.2	58.9
Puueo 1402	72.2	46.4	46.2	39.5	42.1
Puuhuluhulu 11	46.4	29.8	29.7	25.4	27.1
Puuhuluhulu 12	46.4	29.8	29.7	25.4	27.1
Puukapu 11	96.8	62.1	61.9	52.9	56.5
Puuwaawaa 11	100.0	0.0	0.0	0.0	0.0
Puuwaawaa 12	18.8	12.1	12.0	10.3	11.0
Royal Hawaiian	21.0	13.5	13.4	11.5	12.3
Shipman 11	26.4	16.9	16.9	14.4	15.4
Shipman 12	95.9	61.6	61.4	52.4	56.0
South Point 11	803.0	34.0	33.9	29.0	31.0
South Point 12	3.7	2.4	2.4	2.0	2.1
Umauma 11	5.2	3.4	3.3	2.9	3.1
Umauma 12	9.0	5.8	5.8	4.9	5.3
Waika 11	7.8	5.0	5.0	4.3	4.5
Waika 12	138.8	89.1	88.9	75.9	81.1
Waikii 11	29.4	18.9	18.8	16.1	17.2
Waikii 12	13.9	8.9	8.9	7.6	8.1
Waikoloa 11	122.5	78.6	78.4	67.0	71.5
Waikoloa 12	307.1	197.2	196.6	167.9	179.3





Circuit	2021	2022	2023	2024	2025
Waipunahina 11	23.1	14.8	14.8	12.6	13.5
Wright Road 11	65.6	42.1	42.0	35.9	38.3

## Maui Island

Table 16: Maui Island Adjusted DER Growth by Circuit (kW)

Circuit	2021	2022	2023	2024	2025
Haiku 16/1358	169.1	77.2	100.6	94.2	95.6
Haiku 16/1361	49.1	22.4	29.2	27.3	27.7
Hana 41/10277	5.9	2.7	3.5	3.3	3.3
Hana 41/537	9.5	4.4	5.7	5.3	5.4
Hana 41/6528	3.0	1.4	1.8	1.7	1.7
Huelo 74A/Huelo	12.3	5.6	7.3	6.8	6.9
Kahului 8/1264	67.3	30.7	40.0	37.5	38.0
Kahului 8/1265	195.8	89.4	116.4	109.0	110.6
Kahului 8/4048	87.6	40.0	52.1	48.8	49.5
Kahului 8/4049	74.5	34.0	44.3	41.5	42.1
Kahului 8/4050	32.3	14.7	19.2	18.0	18.2
Kailua 9/Kailua	1.0	0.5	0.6	0.6	0.6
Kanaha 2/1244	121.9	55.6	72.5	67.9	68.8
Kanaha 2/1245	82.5	37.7	49.1	45.9	46.6
Kanaha 2/1304	130.5	59.6	77.6	72.7	73.7
Kanaha 2/1305	158.4	72.3	94.2	88.2	89.5
Kanaha 2/1347	147.1	67.2	87.5	82.0	83.1
Kanaha 2/1348	46.1	21.1	27.5	25.7	26.1
Kaonoulu/1590	302.4	138.1	179.9	168.5	170.9



Distribution DER Hosting Capacity Grid Needs | August 2021 Update

Circuit	2021	2022	2023	2024	2025
Kaonoulu/1591	81.8	37.4	48.7	45.6	46.2
Kauhikoa 98/1295	64.0	29.2	38.1	35.7	36.2
Keanae 42/Keanae	2.2	1.0	1.3	1.2	1.3
Kihei 35/1253	118.2	54.0	70.3	65.9	66.8
Kihei 35/1254	260.7	119.0	155.1	145.2	147.3
Kihei 35/1384	343.5	156.8	204.3	191.3	194.0
Kihei 35/1385	99.0	45.2	58.9	55.1	55.9
Kihei 35/1473	243.8	111.3	145.0	135.8	137.7
Kihei 35/1515	498.0	227.3	296.2	277.4	281.3
Kuau 73/4066	56.3	25.7	33.5	31.4	31.8
Kuihelani 209/1653	335.1	153.0	199.3	186.6	189.3
Kuihelani 209/1708	159.4	72.8	94.8	88.8	90.1
Kula 13/1237	213.8	97.6	127.2	119.1	120.8
Kula 13/1238	215.5	98.4	128.2	120.0	121.7
Kula Ag Park 55/1322	39.7	18.1	23.6	22.1	22.4
Lahaina 34/1221	156.8	71.6	93.3	87.3	88.6
Lahaina 34/1223	219.4	100.2	130.5	122.2	124.0
Lahaina 34/1225	44.2	20.2	26.3	24.6	25.0
Lahaina 34/1226	24.8	11.3	14.7	13.8	14.0
Lahaina 34/1390	197.0	89.9	117.2	109.7	111.3
Lahaina 34/1397	15.5	7.1	9.2	8.6	8.7
Lahaina 34/1398	281.1	128.3	167.2	156.5	158.8
Maalaea 39/1285	63.0	28.8	37.5	35.1	35.6
Maalaea 39/1286	83.9	38.3	49.9	46.7	47.4



Distribution DER Hosting Capacity Grid Needs | August 2021 Update

Circuit	2021	2022	2023	2024	2025
Mahinahina 50/1219	159.8	72.9	95.0	89.0	90.3
Mahinahina 50/1380	37.8	17.3	22.5	21.0	21.4
Mahinahina 50/1381	1167.2	76.3	99.4	93.1	94.4
Makawao 12/1234	62.1	28.3	36.9	34.6	35.1
Makawao 12/1235	95.6	43.7	56.9	53.3	54.0
Makawao 12/1236	85.2	38.9	50.7	47.5	48.2
Maui Hardwoods 75/522	15.3	7.0	9.1	8.5	8.6
Napili 29/1232	38.7	17.7	23.0	21.6	21.9
Napili 29/1420	874.7	56.9	74.2	69.5	70.4
Napili 29/1421	72.8	33.3	43.3	40.6	41.2
Onehee 40/4055	96.1	43.9	57.2	53.5	54.3
Onehee 40/4056	39.4	18.0	23.4	22.0	22.3
Paia Mauka 93/4042	95.2	43.5	56.6	53.0	53.8
Peahi 94/1294	85.9	39.2	51.1	47.9	48.5
Pukalani 17/1282	228.1	104.1	135.7	127.1	128.9
Pukalani 17/1283	0.5	0.2	0.3	0.3	0.3
Pukalani 17/1308	320.0	146.1	190.3	178.2	180.8
Pukalani 17/1309	34.0	15.5	20.2	18.9	19.2
Puukolii 23/1270	415.3	189.6	247.0	231.3	234.6
Puukolii 23/1271	86.2	39.3	51.3	48.0	48.7
Puukolii 23/1272	232.7	106.2	138.4	129.6	131.5
Puukolii 23/1273	8.0	3.7	4.8	4.5	4.5
Spreckelsville 92/4043	78.0	35.6	46.4	43.4	44.1
Waiehu 43/1378	148.1	67.6	88.1	82.5	83.7



Distribution DER Hosting Capacity Grid Needs | August 2021 Update

Circuit	2021	2022	2023	2024	2025
Waiehu 43/1379	273.4	124.8	162.6	152.3	154.5
Waiinu 36/1266	81.9	37.4	48.7	45.6	46.3
Waiinu 36/1267	44.0	20.1	26.2	24.5	24.8
Waiinu 36/1492	74.6	34.1	44.4	41.5	42.1
Waiinu 36/1493	610.6	278.7	363.2	340.1	345.0
Waiinu 36/2030	23.5	10.7	14.0	13.1	13.3
Waikapu 77/524	0.0	0.0	0.0	0.0	0.0
Wailea 25/1280	208.7	95.3	124.1	116.2	117.9
Wailea 25/1281	51.4	23.5	30.6	28.6	29.0
Wailea 25/1320	182.1	83.1	108.3	101.4	102.9
Wailea 25/1321	2.3	1.1	1.4	1.3	1.3
Wailea 25/1395	35.8	16.3	21.3	19.9	20.2
Wailea 25/1396	66.1	30.2	39.3	36.8	37.3
Wailea 25/1517	203.6	93.0	121.1	113.4	115.0
Wailea 25/1518	123.3	56.3	73.3	68.7	69.6
Wailuku 3/1290	328.8	150.1	195.6	183.1	185.8
Wailuku 3/1447	219.3	100.1	130.4	122.1	123.9
Wailuku 3/4031	42.2	19.2	25.1	23.5	23.8
Wailuku 3/4037	66.0	30.1	39.2	36.7	37.3
Wailuku Heights 18/493	64.8	29.6	38.5	36.1	36.6
Wailuku Heights 18/529	41.6	19.0	24.7	23.2	23.5



## Lana'i

Table 17: Lana'i Adjusted DER Growth by Circuit (kW)

Circuit	2021	2022	2023	2024	2025
Miki Basin PP 302/1208	14.8	2.8	8.0	11.6	32.0
Miki Basin PP 302/1210	5.1	1.0	2.8	4.0	11.0
Miki Basin PP 302/1212	17.2	3.3	9.2	13.4	37.0

## Moloka'i

Table 18: Moloka'i Adjusted DER Growth by Circuit (kW)

Circuit	2021	2022	2023	2024	2025
Palaau PP 81/105A	49.0	24.2	18.8	38.9	14.8
Palaau PP 81/106B	13.0	6.4	5.0	10.3	3.9
Palaau PP 81/109B	6.6	3.3	2.6	5.3	2.0
Palaau PP 81/110B	12.8	6.3	4.9	10.2	3.9
Palaau PP 81/111A	302.1	25.7	20.0	41.4	15.7
Puunana 80/1466	2.0	1.0	0.8	1.6	0.6
Puunana 80/1467	9.8	4.9	3.8	7.8	3.0
Puunana 80/1468	0.6	0.3	0.2	0.5	0.2



# Appendix C: Hosting Capacity Analysis Results

## Summary

Hosting capacity results in the following tables contain:

- **Circuit Name**
- **Total 2025 DER (kW):** Total anticipated DER in year 2025.
- **Existing Hosting Capacity (kW):** Current circuit hosting capacity (HC).
- **Existing Hosting Capacity Satisfies Need:** Circuits with existing hosting capacity able to accommodate the Total 2025 DER are marked with an “X”.
- **Updated Hosting Capacity (kW):** Updated circuit hosting capacity resulting from the analysis described in Section 3.
- **Updated Hosting Capacity (without Modifications) Satisfies Need:** Circuits with updated hosting capacity able to accommodate the Total 2025 DER without any modifications are marked with an “X”.
- **Updated Hosting Capacity (with Modifications) Satisfies Need:** Circuits with updated hosting capacity and modifications (non-infrastructure investment solutions) able to accommodate the Total 2025 DER are marked with an “X”.
- **Solution Option Required:** Circuits with an identified grid needs are marked with an “X”.

## O’ahu

Table 19: O’ahu Hosting Capacity Analysis Results by Circuit

Circuit Name	Total 2025 DER (kW)	Existing HC (kW)	Existing HC Satisfies Need	Updated HC (kW)	Updated HC (w/o Mods) Satisfies Need	Updated HC (w/ Mods) Satisfies Need	Solution Option Required
AALA	1,887	6,044	x				
AALAPAPA	3,594	4,786	x				
AHUA	1,711	1,561		6,080	x		
AHUI	0	361	x				
AIEA	3,388	3,601	x				
AIEA 2	774	2,986	x				
AIEA 3	275	1,008	x				



Distribution DER Hosting Capacity Grid Needs | August 2021 Update

Circuit Name	Total 2025 DER (kW)	Existing HC (kW)	Existing HC Satisfies Need	Updated HC (kW)	Updated HC (w/o Mods) Satisfies Need	Updated HC (w/ Mods) Satisfies Need	Solution Option Required
AINA KOA	2,115	2,951	x				
AINONI	1,159	1,500	x				
AIRPORT	2,773	5,669	x				
AIRPORT 1	100	2,724	x				
AIRPORT 2	2	1,716	x				
ALA MOANA	303	6,272	x				
ALEWA	435	580	x				
ALIAMANU	3,816	6,346	x				
ANOI	4,032	3,794		6,360	x		
ANUU	3,589	4,073	x				
ARCHER 1	100	2,402	x				
ARCHER 2	336	3,003	x				
ARCHER 3	2,265	7,277	x				
ARCHER 4	278	5,293	x				
AUDITORIUM	876	4,589	x				
BARBERS PT	1,435	7,170	x				
BAY DR	977	1,424	x				
BEACH LOTS	3,691	4,712	x				
BECKLEY	322	304		1,190		x	
BLACK PT	641	1,207		1,207	x		
BWS	1,190	4,337	x				
CARLOS LONG	2,853	3,984	x				
CASTNER	1,745	6,569	x				



Distribution DER Hosting Capacity Grid Needs | August 2021 Update

Circuit Name	Total 2025 DER (kW)	Existing HC (kW)	Existing HC Satisfies Need	Updated HC (kW)	Updated HC (w/o Mods) Satisfies Need	Updated HC (w/ Mods) Satisfies Need	Solution Option Required
CEIP 3	2,996	6,243	x				
CEIP 4	458	1,478	x				
CKT 10	457	2,068	x				
CKT 12	200	3,107	x				
CKT 16	7,411	6,611		10,012	x		
CKT 18	863	4,276	x				
CKT 6	920	2,806	x				
CKT 7	921	4,397	x				
CKT 8	0	1,403	x				
COCONUT GROVE	1,132	1,457	x				
DAIRYMENS	580	2,649	x				
DE RUSSY	13	3,126	x				
DEPOT RD	1,025	2,327	x				
DIAMOND HEAD	1,101	1,452	x				
DOLE 1	2,698	5,673	x				
EKEKELA	822	1,115	x				
ENA 1	303	3,559	x				
ENA 2	8	4,529	x				
ENCHANTED LAKES	3,755	5,155	x				
EWA BEACH 1	4,016	6,550	x				
EWA BEACH 2	3,015	4,257	x				





Distribution DER Hosting Capacity Grid Needs | August 2021 Update

Circuit Name	Total 2025 DER (kW)	Existing HC (kW)	Existing HC Satisfies Need	Updated HC (kW)	Updated HC (w/o Mods) Satisfies Need	Updated HC (w/ Mods) Satisfies Need	Solution Option Required
EWA BEACH 3	3,156	4,468	x				
EWA BEACH 4	5,642	6,970	x				
EWA NUI 1	2,904	6,430	x				
EWA NUI 2	4,294	6,024	x				
FARMERS RD	1,232	1,411		1,411	x		
FORT ST	737	4,340	x				
FORT ST 1	204	3,014	x				
FORT ST 2	479	3,672	x				
FORT ST 3	336	3,667	x				
FORT ST 4	853	2,895	x				
FORT WEAVER 1	3,498	5,458	x				
FORT WEAVER 2	4,644	6,321	x				
FORT WEAVER 3	4,515	5,950	x				
FORT WEAVER 4	2,054	4,293	x				
HAHAIONE	2,338	3,366	x				
HALA 1	2,561	4,003	x				
HALA 2	1,918	4,308	x				
HALA 3	2,804	4,824	x				
HALA 4	1,755	4,351	x				
HALAWA	2,739	6,775	x				
HALEKOU	3,599	5,289	x				



Distribution DER Hosting Capacity Grid Needs | August 2021 Update

Circuit Name	Total 2025 DER (kW)	Existing HC (kW)	Existing HC Satisfies Need	Updated HC (kW)	Updated HC (w/o Mods) Satisfies Need	Updated HC (w/ Mods) Satisfies Need	Solution Option Required
HANUA 1	0	0	x				
HANUA 2	2	344	x				
HAUULA	6,723	2,802		8,630	x		
HAWN PINE	1,591	5,841	x				
HAWN VILLAGE 1	115	3,528	x				
HAWN VILLAGE 2	304	3,052	x				
HEEIA	3,908	5,140	x				
HEIGHTS	1,117	1,355	x				
HELEMANO	2,874	4,550	x				
HIGHLANDS	3,909	6,162	x				
HIKINA	160	523	x				
HILA 1	802	1,968	x				
HILA 2	2,795	3,688	x				
HILA 3	1,781	5,288	x				
HILA 4	400	0		2,323	x		
HILA 5	1,929	6,597	x				
HILA 6	0	0	x				
HOAEAE 1	4,348	6,643	x				
HOAEAE 2	1,196	2,163	x				
HOAEAE 3	2,258	2,846		3,000	x		
HOUGHTAILING	1,104	5,510	x				
HUNAKAI	767	1,892		1,892	x		



Distribution DER Hosting Capacity Grid Needs | August 2021 Update

Circuit Name	Total 2025 DER (kW)	Existing HC (kW)	Existing HC Satisfies Need	Updated HC (kW)	Updated HC (w/o Mods) Satisfies Need	Updated HC (w/ Mods) Satisfies Need	Solution Option Required
ILANIWAI	285	3,605	x				
ILIAINA	1,789	2,541	x				
ILIKAI	153	4,283	x				
INDUSTRIAL	4,126	7,546	x				
IWILEI 1 11KV	1,709	7,190	x				
IWILEI 13	738	3,979	x				
IWILEI 9	717	4,164	x				
KAALAKEI	3,785	5,132	x				
KAENA PT	2,162	2,739	x				
KAHAI	3,922	6,866	x				
KAHALA	1,481	1,976		1,976	x		
KAHALA 3	5,410	1,609		6,232	x		
KAHALA MALL	2,326	2,970	x				
KAHALOA	1,160	1,407		1,630	x		
KAHE	3,273	5,684	x				
KAHUKU	2,014	2,422		4,240	x		
KAI-HARDING	474	583	x				
KAI-KAIMUKI	696	1,162	x				
KAILUA 1	2,498	3,746	x				
KAILUA 2	3,828	7,039	x				
KAILUA HTS	4,279	5,755	x				
KAINALU	1,690	1,047		2,468			x
KAI-WAIALAE	959	1,659	x				



Distribution DER Hosting Capacity Grid Needs | August 2021 Update

Circuit Name	Total 2025 DER (kW)	Existing HC (kW)	Existing HC Satisfies Need	Updated HC (kW)	Updated HC (w/o Mods) Satisfies Need	Updated HC (w/ Mods) Satisfies Need	Solution Option Required
KAI-WILHELMINA	703	930	x				
KAKAAKO 5	90	823	x				
KAKAAKO 6	0	1,646	x				
KAKAAKO 8	1,181	3,781	x				
KAKAAKO 9	1,205	7,502	x				
KALAHEO	1,193	1,462	x				
KALAHEO 1	341	2,344	x				
KALAHEO 2	0	0	x				
KALAKAUA	263	4,831	x				
KALAMA	1,068	1,277	x				
KALIA	0	5,654	x				
KALIHI	104	5,187	x				
KALIHI KAI	618	1,604	x				
KALIHI ST	795	1,021		1,620	x		
KALIHI UKA	513	1,278	x				
KALIHI VALLEY	641	1,701	x				
KALOI 1	915	651		2,979	x		
KAM HWY	1,786	5,123	x				
KAM IV	933	1,322	x				
KAM TERRACE	1,106	1,323	x				
KAMAKEE	687	2,456	x				
KAMANI	99	2,128	x				
KAMOKILA 1	3,001	6,058	x				



Distribution DER Hosting Capacity Grid Needs | August 2021 Update

Circuit Name	Total 2025 DER (kW)	Existing HC (kW)	Existing HC Satisfies Need	Updated HC (kW)	Updated HC (w/o Mods) Satisfies Need	Updated HC (w/ Mods) Satisfies Need	Solution Option Required
KAMOKILA 2	2,196	5,903	x				
KAMOKILA 3	2,986	4,111	x				
KAMOKILA 4	3,027	3,966	x				
KAMOKILA 5	2,901	6,548	x				
KAMOKILA 6	1,375	4,236	x				
KAMOKU 10	1,766	8,363	x				
KAMOKU 9	1,072	6,223	x				
KANAINA	3,489	6,528	x				
KANEKAPOLEI	441	3,308	x				
KANEOHE 5	1,991	2,804	x				
KANEOHE 6	2,911	5,977	x				
KAONOHI 1	495	3,482	x				
KAONOHI 2	3,150	5,066	x				
KAONOHI 3	1,071	4,965	x				
KAONOHI 4	321	4,030	x				
KAPAHULU 1	125	1,355	x				
KAPAHULU 2	0	5,774	x				
KAPAHULU 3	212	4,879	x				
KAPAHULU 4	246	3,629	x				
KAPALAMA	311	587		845	x		
KAP-HARDING	784	1,157	x				
KAPIOLANI 1	1,228	4,867	x				
KAPIOLANI 2	2,196	5,354	x				



Distribution DER Hosting Capacity Grid Needs | August 2021 Update

Circuit Name	Total 2025 DER (kW)	Existing HC (kW)	Existing HC Satisfies Need	Updated HC (kW)	Updated HC (w/o Mods) Satisfies Need	Updated HC (w/ Mods) Satisfies Need	Solution Option Required
KAPIOLANI 3	1,010	4,056	x				
KAP-KAIMUKI	126	1,911	x				
KAPOLEI 1	106	644	x				
KAPOLEI 2	2,160	4,169	x				
KAPOLEI 3	817	3,780	x				
KAPOLEI 4	6,517	2,966		6,727	x		
KAP-WAIALAE	622	1,032	x				
KAUHALE	1,973	6,157	x				
KAWAILOA	1,552	1,133		2,468		x	
KAWELA	3,048	4,800		6,370	x		
KEALAOLU	429	1,120	x				
KEAWE	865	4,502	x				
KEEHI 1	430	2,912	x				
KEEHI 5	1,561	3,166	x				
KEEHI 6	1,399	4,074	x				
KEEHI 7	830	2,866	x				
KEEHI 8	412	1,766	x				
KEOLU DR	2,181	4,497	x				
KEWALO	7,092	7,087		11,693	x		
KEWALO 1	461	3,591	x				
KEWALO 2	460	4,809	x				
KEWALO 3	44	73	x				
KEWALO 4	297	2,953	x				



Distribution DER Hosting Capacity Grid Needs | August 2021 Update

Circuit Name	Total 2025 DER (kW)	Existing HC (kW)	Existing HC Satisfies Need	Updated HC (kW)	Updated HC (w/o Mods) Satisfies Need	Updated HC (w/ Mods) Satisfies Need	Solution Option Required
KEWALO 5	1,253	11,185	x				
KEWALO 6	793	5,907	x				
KEWALO 7	400	0		1,120	x		
KILAUEA 12KV	2,189	6,299	x				
KILAUEA 4KV	953	962		962			x
KIPAPA	1,469	3,487	x				
KO OLINA 1	558	8,395	x				
KO OLINA 2	24	84	x				
KO OLINA 3	0	4,546	x				
KOKOHEAD	2,319	3,252	x				
KOLOA	759	1,519		1,519	x		
KONA ST	100	893	x				
KUAHELANI 1	2,448	4,897	x				
KUAHELANI 2	1,956	4,138	x				
KUAHELANI 3	3,458	7,671	x				
KUAHELANI 4	5,162	10,634	x				
KUAKINI	153	952		750	x		
KUAPA 1	2,071	4,410	x				
KUAPA 2	1,338	1,891	x				
KUAPA 3	2,957	4,110	x				
KUAPA 4	2,040	3,136	x				
KUHIO	325	505	x				
KUHIO 1	89	5,371	x				



Distribution DER Hosting Capacity Grid Needs | August 2021 Update

Circuit Name	Total 2025 DER (kW)	Existing HC (kW)	Existing HC Satisfies Need	Updated HC (kW)	Updated HC (w/o Mods) Satisfies Need	Updated HC (w/ Mods) Satisfies Need	Solution Option Required
KUHIO 2	300	983	x				
KUHIO 3	0	3,562	x				
KUHIO 4	511	3,627	x				
KUILIMA 1	1,075	1,524	x				
KUNIA	826	1,711	x				
KUNIA MAKAI 1	2,118	3,433	x				
KUNIA MAKAI 2	4,361	7,394	x				
KUNIA MAKAI 3	3,536	5,979	x				
KUNIA MAKAI 4	1,438	2,128	x				
LAGOON	488	8,176	x				
LAKESIDE 1	2,043	4,373	x				
LAKESIDE 2	826	2,008	x				
LAKESIDE 3	1,391	5,447	x				
LAKESIDE 4	2,179	3,541	x				
LANIKAI	73	179	x				
LAULIMA	2,627	4,187	x				
LEAHI	2,343	5,460	x				
LEOMELE	2,038	2,938	x				
LEOOLE	2,830	3,527	x				
LIBERTY HOUSE	255	2,502	x				
LIGHTHOUSE	1,196	7,972	x				
LIKELIKE	389	680	x				
LILIHA MAKAI	191	190		820	x		





Distribution DER Hosting Capacity Grid Needs | August 2021 Update

Circuit Name	Total 2025 DER (kW)	Existing HC (kW)	Existing HC Satisfies Need	Updated HC (kW)	Updated HC (w/o Mods) Satisfies Need	Updated HC (w/ Mods) Satisfies Need	Solution Option Required
LOWREY	1,045	1,129		1,300	x		
LUAWAI	3,292	7,351		4,100	x		
LUMIAUUAU	1,766	4,579	x				
MACHADO ST	709	736		1,500	x		
MAHUKONA	1,161	4,985	x				
MAKAHA	3,583	5,685	x				
MAKAHA VALLEY	1,014	1,825	x				
MAKAKILO 1	2,733	4,316	x				
MAKAKILO 2	8,707	8,536		9,561		x	
MAKAKILO 3	3,276	5,277	x				
MAKAKILO 4	1,208	1,943	x				
MAKALAPA-MOANALUA	2,678	4,285	x				
MAKALOA	206	4,748	x				
MALAKOLE	0	0	x				
MALAKOLE 4	5,569	6,493	x				
MANAGERS	553	1,478	x				
MANOA 1	1,875	2,732		2,470	x		
MANOA 2	1,053	1,089		2,180	x		
MANOA 3	2,992	4,168	x				
MANOA 4	0	266	x				
MANOA-MCCULLY	610	4,538	x				



Distribution DER Hosting Capacity Grid Needs | August 2021 Update

Circuit Name	Total 2025 DER (kW)	Existing HC (kW)	Existing HC Satisfies Need	Updated HC (kW)	Updated HC (w/o Mods) Satisfies Need	Updated HC (w/ Mods) Satisfies Need	Solution Option Required
MANOA-PIIKOI	1,344	1,553	x				
MAPUNAPUNA	496	371		3,835	x		
MAPUNAPUNA-MOANALUA	1,422	2,345	x				
MAUKA	8,316	8,894	x				
MAUNALANI	1,722	2,161	x				
MAUNAWILI	0	108	x				
MCCULLY 1	1,138	7,398	x				
MCCULLY 3	1,352	6,268	x				
MCCULLY 5	965	4,264	x				
MIKILUA 1	2,056	6,431	x				
MIKILUA 3	4,969	4,761		5,113	x		
MIKILUA 4	6,031	5,434		6,153	x		
MIKILUA 5	6,506	7,382	x				
MILILANI 1	2,469	4,605	x				
MILILANI 2	1,491	5,475	x				
MILILANI 3	2,019	3,763	x				
MILILANI 4	5,851	7,449	x				
MOIILILI 1	1,098	4,596	x				
MOIILILI 2	910	3,937	x				
MOKAUEA	863	2,933	x				
MOKUOLA	3,501	6,033	x				
MOKUONE 1	100	4,641	x				
MOKUONE 2	1,451	4,421	x				



Distribution DER Hosting Capacity Grid Needs | August 2021 Update

Circuit Name	Total 2025 DER (kW)	Existing HC (kW)	Existing HC Satisfies Need	Updated HC (kW)	Updated HC (w/o Mods) Satisfies Need	Updated HC (w/ Mods) Satisfies Need	Solution Option Required
NIU	2,643	4,171	x				
NUMANA	364	1,154	x				
NUUANU	567	719		2,160	x		
NUUANU 2	1,385	5,155	x				
NUUANU 3	3,203	6,965	x				
OCEAN POINTE 1	4,577	5,876	x				
OCEAN POINTE 2	3,848	5,280	x				
OCEAN POINTE 3	2,964	6,212	x				
OCEAN POINTE 4	1,274	1,425	x				
OLOMANA	1,858	2,936	x				
ONEAWA	883	908		2,008		x	
PAHIA	1,847	1,505		4,310	x		
PAIWA	1,739	3,378	x				
PALEKA	1,948	2,584	x				
PALI	3,303	4,764	x				
PAOKALANI	413	5,271	x				
PAUOA 1	1,624	2,333	x				
PAUOA 2	3,618	4,522	x				
PAWAA KAI	755	4,255	x				
PAWAINA	1,358	1,824	x				
PEARL CITY 1	1,846	5,934	x				



Distribution DER Hosting Capacity Grid Needs | August 2021 Update

Circuit Name	Total 2025 DER (kW)	Existing HC (kW)	Existing HC Satisfies Need	Updated HC (kW)	Updated HC (w/o Mods) Satisfies Need	Updated HC (w/ Mods) Satisfies Need	Solution Option Required
PEARL CITY 2	2,579	5,588	x				
PENINSULA	2,001	6,106	x				
PENSACOLA	1,196	3,860	x				
PIIKOI	410	4,255	x				
PIIKOI 7	620	2,773	x				
PIIKOI 8	2,071	1,993		3,469			x
POAMOHO	0	0	x				
POHAKUPU 4	2,613	4,054	x				
PORTLOCK	1,775	4,113	x				
PUNALUU	2,401	3,552	x				
PUNCHBOWL	543	656		1,240	x		
PUOHALA 1	2,278	4,019	x				
PUOHALA 2	5,113	7,179	x				
PUUHALE	1,677	2,526	x				
PUUNUI	1,008	1,397	x				
QUEEN ST	353	2,128	x				
QUEENS 1	2,566	4,943	x				
QUEENS 2	1,452	1,722	x				
RUGER	448	1,010	x				
SAND ISLAND	859	6,808	x				
SAND ISLAND 1	700	6,285	x				
SAND ISLAND 2	483	3,034	x				
SCHOOL ST	1,961	3,452	x				



Distribution DER Hosting Capacity Grid Needs | August 2021 Update

Circuit Name	Total 2025 DER (kW)	Existing HC (kW)	Existing HC Satisfies Need	Updated HC (kW)	Updated HC (w/o Mods) Satisfies Need	Updated HC (w/ Mods) Satisfies Need	Solution Option Required
SCHOOL ST 3	1,686	5,183	x				
SHAFTER	1,048	3,086	x				
SHERATON 1	175	1,536	x				
SHERATON 2	112	4,551	x				
SHOPPING CTR	1,686	4,165	x				
SOUTH RAMP 1	1,228	3,765	x				
ST LOUIS	2,251	2,853	x				
ST LOUIS HTS	111	337	x				
THURSTON	999	5,558	x				
TOWN	4	144	x				
UALENA	1,846	5,228	x				
UPLANDS	1,192	1,379	x				
UWAPO 1	3,948	5,433	x				
UWAPO 2	1,227	1,637	x				
UWAPO 3	4,044	5,881	x				
UWAPO 4	122	924	x				
WAHIAWA HTS	3,388	4,206	x				
WAHIAWA PROPER	1,323	5,964	x				
WAIKAMILO 1	576	2,530	x				
WAIKAMILO 2	1,232	5,490	x				
WAIKAMILO 3	2,449	5,827	x				
WAIKAMILO 4	1,723	3,697	x				



Distribution DER Hosting Capacity Grid Needs | August 2021 Update

Circuit Name	Total 2025 DER (kW)	Existing HC (kW)	Existing HC Satisfies Need	Updated HC (kW)	Updated HC (w/o Mods) Satisfies Need	Updated HC (w/ Mods) Satisfies Need	Solution Option Required
WAIKAMILO-IWILEI	415	959	x				
WAIKAMILO-KAPALAMA	3,117	9,020	x				
WAIALAE NUI	1,984	3,646	x				
WAIALAE SC	0	746	x				
WAIALUA	1,815	1,711		3,302		x	
WAIAWA 1	4,161	6,447	x				
WAIAWA 2	3,506	9,144	x				
WAIAWA 3	3,391	7,605	x				
WAIAWA 4	2,234	4,257	x				
WAIHEE 1	2,866	3,804	x				
WAIHEE 2	1,627	2,101	x				
WAIHEE 3	571	660		1,120	x		
WAIHEE 4	3,029	4,189	x				
WAIKELE CTR	199	3,133	x				
WAIKIKI 1	239	1,844	x				
WAIKIKI 2	173	6,144	x				
WAIKIKI 3	627	6,603	x				
WAIKIKI 4	230	6,104	x				
WAIKIKI 5	296	3,888	x				
WAIKIKI 6	394	4,256	x				
WAILANI	1,261	2,982	x				
WAILUPE	5,076	6,579	x				



Distribution DER Hosting Capacity Grid Needs | August 2021 Update

Circuit Name	Total 2025 DER (kW)	Existing HC (kW)	Existing HC Satisfies Need	Updated HC (kW)	Updated HC (w/o Mods) Satisfies Need	Updated HC (w/ Mods) Satisfies Need	Solution Option Required
WAIMALU 1	3,543	6,268	x				
WAIMALU 2	2,451	4,994	x				
WAIMALU 3	4,653	5,984	x				
WAIMALU 4	2,429	3,523	x				
WAIMANALO	1,557	2,248	x				
WAIMANO 5	1,536	2,078	x				
WAIMANO 6	2,148	4,506	x				
WAIMANO HOME RD	3,567	5,099	x				
WAIMEA 1	644	788	x				
WAIMEA 2	2,421	3,168	x				
WAIOMAO	3,450	5,743	x				
WAIPAHU	5,979	8,874	x				
WAIPIO 1	1,717	4,249	x				
WAIPIO 2	1,496	4,040	x				
WAIWAI	1,365	2,823	x				
WAI-WILHELMINA	1,117	1,376	x				
WHITMORE	41	308	x				
WILIWILI	1,842	2,293	x				
WILIWILI 2	2,054	2,412	x				
WOODLAWN	905	1,242	x				



## Hawai'i Island

Table 20: Hawai'i Island Hosting Capacity Analysis Results by Circuit

Circuit Name	Total 2025 DER (kW)	Existing HC (kW)	Existing HC Satisfies Need	Updated HC (kW)	Updated HC (w/o Mods) Satisfies Need	Updated HC (w/ Mods) Satisfies Need	Solution Option Required
Ainaloa 11	894	1,722	x				
Ainaloa 12	629	1,319	x				
Anaehoomalu 11	225	1,659	x				
Anaehoomalu 12	383	2,150	x				
Anaehoomalu 13	273	4,245	x				
Captain Cook 11	1,884	3,876	x				
Captain Cook 12	1,440	1,795	x				
Hakalau 1	207	319	x				
Halaula 1	753	743		1,375			x
Halaula 2	0	0	x				
Hale Pohaku 11	299	85		3,730	x		
Hale Pohaku 12	126	83		2,370	x		
Haleaha 11	609	3,050	x				
Haleaha 12	1,888	4,433	x				
Hawaiian Beaches 11	960	2,129	x				
Hawaiian Beaches 12	7	127	x				
Hawaiian Paradise Park 11	902	3,346	x				
Hawaiian Paradise Park 12	1,749	2,819	x				





**Distribution DER Hosting Capacity Grid Needs | August 2021 Update**

Circuit Name	Total 2025 DER (kW)	Existing HC (kW)	Existing HC Satisfies Need	Updated HC (kW)	Updated HC (w/o Mods) Satisfies Need	Updated HC (w/ Mods) Satisfies Need	Solution Option Required
Hawaiian Paradise Park 13	4,609	0		5,240	x		
Hawaiian Paradise Park 14	783	0		3,570	x		
Hawi 1	615	1,309	x				
Hawi 2	478	1,748	x				
Honokaa 12	715	624		1,300		x	
Honokaa 14	957	1,597	x				
Hononu 1	280	272		900		x	
Host Park 11	1,214	943		3,020	x		
Host Park 12	0	0	x				
Host Park 13	102	568	x				
Host Park 14	644	750	x				
Huehue 11	7,076	7,997	x				
Kahaluu 11	2,516	3,221	x				
Kahaluu 12	1,336	5,034	x				
Kahaluu 14	331	1,183	x				
Kahaluu 15	2,157	1,857		5,000	x		
Kailua 11	2,829	7,029	x				
Kailua 12	232	5,558	x				
Kailua 15	3,923	9,123	x				
Kaloko 11	1,934	2,756	x				
Kaloko 12	373	215		900	x		
Kaloko 13	1,513	1,818	x				



Distribution DER Hosting Capacity Grid Needs | August 2021 Update

Circuit Name	Total 2025 DER (kW)	Existing HC (kW)	Existing HC Satisfies Need	Updated HC (kW)	Updated HC (w/o Mods) Satisfies Need	Updated HC (w/ Mods) Satisfies Need	Solution Option Required
Kaloko 14	54	715	x				
Kamuela 11	44	2,255	x				
Kamuela 12	1,434	2,107	x				
Kanoelehua 11	863	1,223	x				
Kanoelehua 1101	930	3,607	x				
Kanoelehua 12	747	424		2,600	x		
Kanoelehua 13	122	81		1,200	x		
Kanoelehua 14	1,391	2,676	x				
Kanoelehua 1401	1,288	764		3,000	x		
Kanoelehua 15	1,643	599		5,000	x		
Kanoelehua 17	550	4,602	x				
Kapua 11	1,557	2,043	x				
Kapua 12	850	6,199	x				
Kauhale 11	1,108	864		2,380		x	
Kauhale 12	188	0		2,010		x	
Kaumana 11	2,773	3,406	x				
Kaumana 12	802	1,425	x				
Kawaihae 11	258	299	x				
Kawaihae 12	451	548	x				
Kawaihae 13	22	62	x				
Kawailani 11	2,386	2,699	x				
Kawailani 12	2,280	2,913	x				
Keahole Airport 11	1,277	1,252		1,800		x	



**Distribution DER Hosting Capacity Grid Needs | August 2021 Update**

Circuit Name	Total 2025 DER (kW)	Existing HC (kW)	Existing HC Satisfies Need	Updated HC (kW)	Updated HC (w/o Mods) Satisfies Need	Updated HC (w/ Mods) Satisfies Need	Solution Option Required
Keahole Airport 12	356	1,274	x				
Keahole Airport 13	812	940	x				
Keahuolu 11	247	1,354	x				
Keahuolu 12	660	2,471	x				
Kealakehe 11	1,019	1,579	x				
Kealia 11	341	965	x				
Kealia 12	572	804	x				
Keauhou 11	1,256	1,674	x				
Keauhou 13	1,397	2,328	x				
Komohana 12	3,720	1,355		6,395		x	
Komohana 13	3,382	6,695	x				
Komohana 14	260	912	x				
Kuakini 11	4,472	4,854	x				
Kuakini 13	1,063	5,800	x				
Kuakini 14	4,420	6,100	x				
Kulani 12	37	120	x				
Kurtistown 12	1,073	480		1,350		x	
Lalamilo 11	834	1,839	x				
Lalamilo 12	308	4,678	x				
Laupahoehoe 1	102	133	x				
Laupahoehoe 2	216	190		250		x	
Maliu Ridge 11	393	471	x				
Maliu Ridge 12	491	957	x				



Distribution DER Hosting Capacity Grid Needs | August 2021 Update

Circuit Name	Total 2025 DER (kW)	Existing HC (kW)	Existing HC Satisfies Need	Updated HC (kW)	Updated HC (w/o Mods) Satisfies Need	Updated HC (w/ Mods) Satisfies Need	Solution Option Required
Mauna Lani 11	2,795	7,823	x				
Mauna Lani 13	974	1,701	x				
Mauna Lani 14	4,248	2,805		4,350	x		
Mountain View 11	1,135	2,429	x				
Mountain View 12	299	406	x				
Namakani Paio	216	128		1,810		x	
Ookala	193	117		2,440		x	
Orchid Isle 11	69	43		2,590		x	
Orchid Isle 12	394	219		2,530		x	
Ouli 11	603	4,811	x				
Ouli 12	1,134	4,202	x				
Paauilo 1	281	172		300		x	
Pahala 11	403	851	x				
Pahala 12	80	310	x				
Palani 11	110	2,390	x				
Palani 12	2,329	4,171	x				
Palani 13	0	0	x				
Palani 14	794	0		3,970		x	
Panaewa 11	1,255	2,681	x				
Panaewa 12	2,322	1,483		5,465		x	
Papaaloa 1	192	401	x				
Papaaloa 2	125	519	x				
Poopoomino 11	1,777	3,223	x				



Distribution DER Hosting Capacity Grid Needs | August 2021 Update

Circuit Name	Total 2025 DER (kW)	Existing HC (kW)	Existing HC Satisfies Need	Updated HC (kW)	Updated HC (w/o Mods) Satisfies Need	Updated HC (w/ Mods) Satisfies Need	Solution Option Required
Poopoomino 12	909	4,738	x				
Poopoomino 13	699	2,314	x				
Poopoomino 14	1,700	2,830	x				
Punaluu 11	16	1,118	x				
Punaluu 12	182	678	x				
Puueo 11	1,453	836		2,180		x	
Puueo 12	1,493	1,070		9,080		x	
Puueo 1402	1,067	4,399	x				
Puuhuluhulu 11	686	124		2,770	x		
Puuhuluhulu 12	686	648		4,080	x		
Puukapu 11	1,431	2,037	x				
Puuwaawaa 11	100	0		180			x
Puuwaawaa 12	278	755	x				
Royal Hawaiian	310	802	x				
Shipman 11	390	16		400	x		
Shipman 12	1,418	1,008		4,000	x		
South Point 11	1,534	1,582	x				
South Point 12	54	174	x				
Umauma 11	77	146	x				
Umauma 12	134	126		250	x		
Waika 11	115	700	x				
Waika 12	2,052	2,981	x				
Waikii 11	435	694	x				



Circuit Name	Total 2025 DER (kW)	Existing HC (kW)	Existing HC Satisfies Need	Updated HC (kW)	Updated HC (w/o Mods) Satisfies Need	Updated HC (w/ Mods) Satisfies Need	Solution Option Required
Waikii 12	205	0		3,650		x	
Waikoloa 11	1,811	4,400	x				
Waikoloa 12	4,540	4,055		4,910		x	
Waipunahina 11	341	435	x				
Wright Road 11	970	1,606	x				

## Maui Island

Table 21: Maui Island Hosting Capacity Analysis Results by Circuit

Circuit Name	Total 2025 DER (kW)	Existing HC (kW)	Existing HC Satisfies Need	Updated HC (kW)	Updated HC (w/o mods) Satisfies Need	Updated HC (w/ mods) Satisfies Need	Solution Option Required
Haiku 16/1358	2,413	3,378	x				
Haiku 16/1361	801	1,261	x				
Hana 41/10277	85	0		181	x		
Hana 41/537	136	0		229	x		
Hana 41/6528	43	0		116	x		
Huelo 74A/Huelo	175	192	x				
Kahului 8/1264	961	3,266	x				
Kahului 8/1265	2,793	3,685	x				
Kahului 8/4048	1,250	1,420	x				
Kahului 8/4049	1,063	338		1,600		x	
Kahului 8/4050	461	1,100	x				
Kailua 9/Kailua	15	67	x				



**Distribution DER Hosting Capacity Grid Needs | August 2021 Update**

Circuit Name	Total 2025 DER (kW)	Existing HC (kW)	Existing HC Satisfies Need	Updated HC (kW)	Updated HC (w/o mods) Satisfies Need	Updated HC (w/ mods) Satisfies Need	Solution Option Required
Kanaha 2/1244	1,739	5,049	x				
Kanaha 2/1245	1,177	1,862	x				
Kanaha 2/1304	1,910	4,448	x				
Kanaha 2/1305	2,321	3,973	x				
Kanaha 2/1347	2,349	6,172	x				
Kanaha 2/1348	858	8,362	x				
Kaonoulu/1590	4,315	0		6,000	x		
Kaonoulu/1591	1,168	0		3,000	x		
Kauhikoa 98/1295	907	1,143	x				
Kearnae 42/Kearnae	32	173	x				
Kihei 35/1253	1,682	5,287	x				
Kihei 35/1254	3,692	6,100	x				
Kihei 35/1384	8,481	1,159		9,900	x		
Kihei 35/1385	1,401	1,847	x				
Kihei 35/1473	3,452	0		5,657	x		
Kihei 35/1515	7,051	7,610	x				
Kuau 73/4066	797	552		900	x		
Kuihelani 209/1653	4,745	0		5,223		x	
Kuihelani 209/1708	2,757	0		4,260		x	
Kula 13/1237	3,027	2,659		3,800	x		
Kula 13/1238	3,080	3,227	x				
Kula Ag Park 55/1322	762	1,252	x				



Distribution DER Hosting Capacity Grid Needs | August 2021 Update

Circuit Name	Total 2025 DER (kW)	Existing HC (kW)	Existing HC Satisfies Need	Updated HC (kW)	Updated HC (w/o mods) Satisfies Need	Updated HC (w/ mods) Satisfies Need	Solution Option Required
Lahaina 34/1221	2,240	4,090	x				
Lahaina 34/1223	5,977	6,427	x				
Lahaina 34/1225	626	2,139	x				
Lahaina 34/1226	351	1,485	x				
Lahaina 34/1390	2,807	0		4,000	x		
Lahaina 34/1397	219	1,797	x				
Lahaina 34/1398	4,730	972		7,000			x
Maalaea 39/1285	892	4,212	x				
Maalaea 39/1286	1,207	2,420	x				
Mahinahina 50/1219	2,512	12,478	x				
Mahinahina 50/1380	785	1,283	x				
Mahinahina 50/1381	3,617	5,289	x				
Makawao 12/1234	899	1,385	x				
Makawao 12/1235	1,504	1,537	x				
Makawao 12/1236	1,207	1,316	x				
Maui Hardwoods 75/522	466	1,504	x				
Napili 29/1232	548	4,998	x				
Napili 29/1420	3,016	4,252	x				
Napili 29/1421	1,031	1,593	x				
Onehee 40/4055	1,361	1,700	x				
Onehee 40/4056	558	1,300	x				
Paia Mauka 93/4042	1,348	522		1,500			x





Distribution DER Hosting Capacity Grid Needs | August 2021 Update

Circuit Name	Total 2025 DER (kW)	Existing HC (kW)	Existing HC Satisfies Need	Updated HC (kW)	Updated HC (w/o mods) Satisfies Need	Updated HC (w/ mods) Satisfies Need	Solution Option Required
Peahi 94/1294	1,692	1,457		2,001		x	
Pukalani 17/1282	3,250	2,927		5,983		x	
Pukalani 17/1283	7	1,060	x				
Pukalani 17/1308	4,534	5,156	x				
Pukalani 17/1309	481	1,315	x				
Puukolii 23/1270	5,880	14,133	x				
Puukolii 23/1271	1,220	4,446	x				
Puukolii 23/1272	3,295	5,865	x				
Puukolii 23/1273	113	731	x				
Spreckelsville 92/4043	1,114	0		1,260	x		
Waiehu 43/1378	2,367	3,500	x				
Waiehu 43/1379	3,871	3,923	x				
Waiinu 36/1266	1,160	3,822	x				
Waiinu 36/1267	623	1,760	x				
Waiinu 36/1492	1,056	3,485	x				
Waiinu 36/1493	8,646	8,022		12,000		x	
Waiinu 36/2030	333	849	x				
Waikapu 77/524	0	827	x				
Wailea 25/1280	2,955	4,155	x				
Wailea 25/1281	727	3,060	x				
Wailea 25/1320	2,579	6,017	x				
Wailea 25/1321	33	3,997	x				



Circuit Name	Total 2025 DER (kW)	Existing HC (kW)	Existing HC Satisfies Need	Updated HC (kW)	Updated HC (w/o mods) Satisfies Need	Updated HC (w/ mods) Satisfies Need	Solution Option Required
Wailea 25/1395	507	4,019	x				
Wailea 25/1396	936	3,574	x				
Wailea 25/1517	2,883	2,705		3,309		x	
Wailea 25/1518	1,746	1,633		4,000		x	
Wailuku 3/1290	4,656	3,242		5,000	x		
Wailuku 3/1447	3,147	5,574	x				
Wailuku 3/4031	597	1,079	x				
Wailuku 3/4037	934	573		1,200	x		
Wailuku Heights 18/493	917	1,300	x				
Wailuku Heights 18/529	599	1,400	x				

## Lana'i

Table 22: Lana'i Hosting Capacity Analysis Results by Circuit

Circuit Name	Total 2025 DER (kW)	Existing HC (kW)	Existing HC Satisfies Need	Updated HC (kW)	Updated HC (w/o mods) Satisfies Need	Updated HC (w/ mods) Satisfies Need	Solution Option Required
Miki Basin PP 302/1208	391	386		2,700			x
Miki Basin PP 302/1210	2,164	2,154		3,900			x
Miki Basin PP 302/1212	452	2,664	x				



## Moloka'i

Table 23: Moloka'i Hosting Capacity Analysis Results by Circuit

Circuit Name	Total 2025 DER (kW)	Existing HC (kW)	Existing HC Satisfies Need	Updated HC (kW)	Updated HC (w/o mods) Satisfies Need	Updated HC (w/ mods) Satisfies Need	Solution Option Required
Palaau PP 81/105A	964	1,026	x				
Palaau PP 81/106B	256	282	x				
Palaau PP 81/109B	131	125		800			x
Palaau PP 81/110B	260	212		1,000			x
Palaau PP 81/111A	1,277	823		1,650			x
Puunana 80/1466	40	1,061	x				
Puunana 80/1467	194	613	x				
Puunana 80/1468	11	532	x				



## Appendix D: Total DER and Hosting Capacity by Circuit

### O'ahu

Table 24: O'ahu Total Anticipated DER and Hosting Capacity by Circuit (kW)

Circuit	Executed DER	Total Anticipated DER by Year					Hosting Capacity	
		2021	2022	2023	2024	2025	Existing HC	Updated HC
Ahua	960	1,013	1,239	1,356	1,444	1,711	1,561	6,080
Anoi	3,761	3,821	3,887	3,932	3,995	4,032	3,794	6,360
Beckley	211	218	321	321	321	322	304	1,190
Black Pt	617	624	632	632	636	641	1,207	1,207
Ckt 16	2,215	6,892	6,997	7,106	7,409	7,411	6,611	10,012
Farmers Rd	947	1,095	1,134	1,152	1,180	1,232	1,411	1,411
Hauula	1,534	6,541	6,612	6,657	6,703	6,723	2,802	8,630
Hila 4	400	400	400	400	400	400	0	2,323
Hoaeae 3	1,134	1,391	1,887	2,000	2,138	2,258	2,846	3,000
Hunakai	680	691	709	734	745	767	1,892	1,892
Kahala	1,334	1,381	1,411	1,422	1,448	1,481	1,976	1,976
Kahala 3	1,013	5,026	5,171	5,213	5,291	5,410	1,609	6,232
Kahaloa	1,033	1,075	1,106	1,114	1,139	1,160	1,407	1,630
Kahuku	1,454	1,605	1,762	1,772	1,855	2,014	2,422	4,240
Kainalu	1,453	1,477	1,505	1,621	1,656	1,690	1,047	2,468
Kalihi St	676	714	739	757	768	795	1,021	1,620
Kaloi 1	715	715	815	815	915	915	651	2,979
Kapalama	244	258	281	291	298	311	587	845



**Distribution DER Hosting Capacity Grid Needs | August 2021 Update**

Circuit	Executed DER	Total Anticipated DER by Year					Hosting Capacity	
		2021	2022	2023	2024	2025	Existing HC	Updated HC
Kapolei 4	1,289	6,357	6,428	6,455	6,488	6,517	2,966	6,727
Kawailoa	1,110	1,248	1,341	1,396	1,497	1,552	1,133	2,468
Kawela	2,379	2,534	2,665	2,786	2,811	3,048	4,800	6,370
Kewalo	2,009	2,095	2,169	2,210	7,036	7,092	7,087	11,693
Kewalo 7	0	0	200	300	300	400	0	1,120
Kilauea 4kv	869	894	917	930	945	953	962	962
Koloa	654	688	694	700	733	759	1,519	1,519
Kuakini	110	123	133	141	148	153	952	750
Liliha Makai	35	42	43	47	52	191	190	820
Lowrey	870	898	990	1,008	1,026	1,045	1,129	1,300
Luawai	2,336	2,826	2,941	3,035	3,075	3,292	7,351	4,100
Machado St	543	566	677	682	691	709	736	1,500
Makakilo 2	4,657	4,971	8,327	8,391	8,478	8,707	8,536	9,561
Manoa 1	1,735	1,791	1,823	1,845	1,855	1,875	2,732	2,470
Manoa 2	724	759	895	916	932	1,053	1,089	2,180
Mapunapuna	228	277	352	359	400	496	371	3,835
Mikilua 3	3,778	4,005	4,228	4,441	4,821	4,969	4,761	5,113
Mikilua 4	5,017	5,464	5,718	5,764	5,785	6,031	5,434	6,153
Nuuanu	338	361	375	495	515	567	719	2,160
Oneawa	805	831	847	856	872	883	908	2,008
Pahia	1,073	1,407	1,595	1,635	1,689	1,847	1,505	4,310
Piikoi 8	1,458	1,632	1,826	1,984	2,025	2,071	1,993	3,469
Punchbowl	425	479	490	528	531	543	656	1,240



Circuit	Executed DER	Total Anticipated DER by Year					Hosting Capacity	
		2021	2022	2023	2024	2025	Existing HC	Updated HC
Waialua	1,335	1,427	1,594	1,715	1,769	1,815	1,711	3,302
Waihee 3	395	405	424	435	446	571	660	1,120

## Hawai'i Island

Table 25: Hawai'i Island Total Anticipated DER and Hosting Capacity by Circuit (kW)

Circuit	Executed DER	Total Anticipated DER by Year					Hosting Capacity	
		2021	2022	2023	2024	2025	Existing HC	Updated HC
Halaula 1	585	630	663	696	724	753	743	1,375
Hale Pohaku 11	233	250	263	276	288	299	85	3,730
Hale Pohaku 12	98	106	111	117	121	126	83	2,370
Hawaiian Paradise Park 13	2,747	2,959	3,112	3,265	3,396	3,536	0	5,240
Hawaiian Paradise Park 14	467	503	529	555	577	601	0	3,570
Honokaa 12	555	598	629	660	687	715	624	1,300
Honomu 1	217	234	246	258	269	280	272	900
Host Park 11	943	1,016	1,069	1,121	1,166	1,214	943	3,020
Kahaluu 15	1,676	1,805	1,899	1,992	2,072	2,157	1,857	5,000
Kaloko 12	290	312	329	345	359	373	215	900
Kanoelehua 12	585	628	660	691	718	747	424	2,600
Kanoelehua 13	95	102	108	113	117	122	81	1,200
Kanoelehua 1401	1,001	1,078	1,134	1,189	1,237	1,288	764	3,000
Kanoelehua 15	1,276	1,375	1,446	1,517	1,578	1,643	599	5,000



Distribution DER Hosting Capacity Grid Needs | August 2021 Update

Circuit	Executed DER	Total Anticipated DER by Year					Hosting Capacity	
		2021	2022	2023	2024	2025	Existing HC	Updated HC
Kauhale 11	866	931	978	1,025	1,065	1,108	864	2,380
Kauhale 12	146	158	166	174	181	188	0	2,010
Keahole Airport 11	992	1,069	1,124	1,179	1,227	1,277	1,252	1,800
Komohana 12	2,890	3,113	3,275	3,436	3,573	3,720	1,355	6,395
Kurtistown 12	834	898	945	991	1,031	1,073	480	1,350
Laupahoe 2	168	181	190	199	207	216	190	250
Mauna Lani 14	3,300	3,554	3,739	3,923	4,080	4,248	2,805	4,350
Namakani Paio	168	181	190	199	207	216	128	1,810
Ookala	150	161	170	178	185	193	117	2,440
Orchid Isle 11	54	58	61	64	67	69	43	2,590
Orchid Isle 12	306	330	347	364	379	394	219	2,530
Paaui 1	218	235	247	259	269	281	172	300
Palani 14	617	665	699	733	763	794	0	3,970
Panaewa 12	1,825	1,958	2,055	2,151	2,234	2,322	1,483	5,465
Puueo 11	1,129	1,216	1,279	1,342	1,395	1,453	836	2,180
Puueo 12	1,160	1,249	1,314	1,378	1,434	1,493	1,070	9,080
Puuhuluhulu 11	533	574	604	634	659	686	124	2,770
Puuhuluhulu 12	533	574	604	634	659	686	648	4,080
Puuwaawaa 11	0	100	100	100	100	100	0	180
Shipman 11	303	326	343	360	374	390	16	400
Shipman 12	1,102	1,187	1,248	1,310	1,362	1,418	1,008	4,000
Umauma 12	104	112	118	123	128	134	126	250
Waikii 12	159	172	181	190	197	205	0	3,650



Circuit	Executed DER	Total Anticipated DER by Year					Hosting Capacity	
		2021	2022	2023	2024	2025	Existing HC	Updated HC
Waikoloa 12	3,527	3,799	3,997	4,193	4,361	4,540	4,055	4,910

## Maui Island

Table 26: Maui Island Total Anticipated DER and Hosting Capacity by Circuit (kW)

Circuit	Executed DER	Total Anticipated DER by Year					Hosting Capacity	
		2021	2022	2023	2024	2025	Existing HC	Updated HC
Hana 41/10277	66	72	74	78	81	85	0	181
Hana 41/537	106	115	120	125	131	136	0	229
Hana 41/6528	33	36	38	39	41	43	0	116
Kahului 8/4049	826	901	935	979	1,021	1,063	338	1,600
Kaonoulu/1590	0	3,658	3,796	3,976	4,144	4,315	0	6,000
Kaonoulu/1591	0	990	1,027	1,076	1,121	1,168	0	3,000
Kihei 35/1384	7,429	7,735	7,891	8,096	8,287	8,481	1,159	9,900
Kihei 35/1473	900	2,922	3,033	3,179	3,314	3,452	0	5,657
Kuau 73/4066	625	675	700	734	765	797	552	900
Kuihelani 209/1653	3,718	4,016	4,169	4,369	4,555	4,745	0	5,223
Kuihelani 209/1708	2,269	2,411	2,484	2,578	2,667	2,757	0	4,260
Kula 13/1237	2,372	2,562	2,660	2,787	2,906	3,027	2,659	3,800
Lahaina 34/1390	2,204	2,379	2,469	2,586	2,696	2,807	0	4,000
Lahaina 34/1398	3,868	4,119	4,247	4,414	4,571	4,730	972	7,000
Paia Mauka 93/4042	1,056	1,141	1,184	1,241	1,294	1,348	522	1,500
Peahi 94/1294	1,428	1,505	1,544	1,595	1,643	1,692	1,457	2,001





Circuit	Executed DER	Total Anticipated DER by Year					Hosting Capacity	
		2021	2022	2023	2024	2025	Existing HC	Updated HC
Pukalani 17/1282	2,551	2,754	2,858	2,994	3,121	3,250	2,927	5,983
Spreckelsville 92/4043	875	945	980	1,027	1,070	1,114	0	1,260
Waiinu 36/1493	6,775	7,319	7,598	7,961	8,301	8,646	8,022	12,000
Wailea 25/1517	2,259	2,441	2,534	2,655	2,768	2,883	2,705	3,309
Wailea 25/1518	1,368	1,478	1,534	1,607	1,676	1,746	1,633	4,000
Wailuku 3/1290	3,648	3,941	4,091	4,287	4,470	4,656	3,242	5,000
Wailuku 3/4037	732	790	821	860	897	934	573	1,200

## Lana'i

Table 27: Lana'i Total Anticipated DER and Hosting Capacity by Circuit (kW)

Circuit	Executed DER	Total Anticipated DER by Year					Hosting Capacity	
		2021	2022	2023	2024	2025	Existing HC	Updated HC
Miki Basin PP 302/1208	321	336	339	347	359	391	386	2,700
Miki Basin PP 302/1210	2,141	2,146	2,147	2,149	2,153	2,164	2,154	3,900



## Moloka'i

Table 28: Moloka'i Total Anticipated DER and Hosting Capacity by Circuit (kW)

Circuit	Executed DER	Total Anticipated DER by Year					Hosting Capacity	
		2021	2022	2023	2024	2025	Existing HC	Updated HC
Palaau PP 81/109B	111	118	121	123	129	131	125	800
Palaau PP 81/110B	222	235	241	246	256	260	212	1,000
Palaau PP 81/111A	872	1,175	1,200	1,220	1,262	1,277	823	1,650



SERVICE LIST  
(Docket No. 2018-0165)

DEAN NISHINA  
EXECUTIVE DIRECTOR  
DEPARTMENT OF COMMERCE AND CONSUMER AFFAIRS  
DIVISION OF CONSUMER ADVOCACY  
P.O. Box 541  
Honolulu, HI 96809  
[Dean.K.Nishina@dcca.hawaii.gov](mailto:Dean.K.Nishina@dcca.hawaii.gov)

1 Copy  
Electronic Transmission

JOSEPH K. KAMELAMELA  
CORPORATION COUNSEL  
ANGELIC M.H. HALL  
DEPUTY CORPORATION COUNSEL  
COUNTY OF HAWAI'I  
101 Aupuni Street, Suite 325  
Hilo, Hawaii 96720  
Attorneys for COUNTY OF HAWAI'I  
[AngelicMalia.Hall@hawaiicounty.gov](mailto:AngelicMalia.Hall@hawaiicounty.gov)

1 Copy  
Electronic Transmission

ISAAC H. MORIWAKE  
KYLIE W. WAGER CRUZ  
Earthjustice  
850 Richards Street, Suite 400  
Honolulu, HI 96813  
Attorneys for BLUE PLANET FOUNDATION  
[imoriwake@earthjustice.org](mailto:imoriwake@earthjustice.org)  
[kwager@earthjustice.org](mailto:kwager@earthjustice.org)

1 Copy  
Electronic Transmission

WILLIAM J. ROLSTON  
DIRECTOR – ENERGY ISLAND  
73-4101 Lapa‘au Place  
Kailua Kona, Hawaii 96740-8424  
[willenergyisland@gmail.com](mailto:willenergyisland@gmail.com)

1 Copy  
Electronic Transmission

BEREN ARGETSINGER  
Keyes & Fox LLP  
P.O. Box 166  
Burdett, NY 14818  
Counsel for HAWAI'I PV COALITION  
[bargetsinger@keyesfox.com](mailto:bargetsinger@keyesfox.com)

1 Copy  
Electronic Transmission

TIM LINDL  
Keyes & Fox LLP  
580 California Street, 12th Floor  
San Francisco, CA 94104  
Counsel for HAWAI'I PV COALITION  
[tlindl@keyesfox.com](mailto:tlindl@keyesfox.com)

1 Copy  
Electronic Transmission

SERVICE LIST  
(Docket No. 2018-0165)

ROBERT R. MOULD  
HAWAII SOLAR ENERGY ASSOCIATION  
PO Box 37070  
Honolulu, HI 96817  
[rmould@hsea.org](mailto:rmould@hsea.org)

1 Copy  
Electronic Transmission

HENRY Q CURTIS  
VICE PRESIDENT FOR CONSUMER AFFAIRS  
LIFE OF THE LAND  
P.O. Box 37158  
Honolulu, Hawaii 96837  
[henry.lifeoftheland@gmail.com](mailto:henry.lifeoftheland@gmail.com)

1 Copy  
Electronic Transmission

DOUGLAS A. CODIGA  
MARK F. ITO  
Schlack Ito  
A Limited Liability Law Company  
Topa Financial Center  
745 Fort Street, Suite 1500  
Honolulu, Hawaii 96813  
Attorneys for PROGRESSION HAWAII OFFSHORE WIND, LLC  
[dcodiga@schlackito.com](mailto:dcodiga@schlackito.com)

1 Copy  
Electronic Transmission

GERALD A. SUMIDA  
ARSIMA A. MULLER  
Carlsmith Ball LLP  
ASB Tower, Suite 2100  
1001 Bishop Street  
Honolulu, HI 96813  
Attorneys for ULUPONO INITIATIVE LLC  
[gsumida@carlsmith.com](mailto:gsumida@carlsmith.com)  
[amuller@carlsmith.com](mailto:amuller@carlsmith.com)

1 Copy  
Electronic Transmission

## Chun, Marisa

---

**From:** puc@hawaii.gov  
**Sent:** Tuesday, August 3, 2021 4:25 PM  
**To:** Chun, Marisa  
**Subject:** Hawaii PUC eFiling Confirmation of Filing

**[This email is coming from an EXTERNAL source. Please use caution when opening attachments or links in suspicious email.]**

Your eFile document has been filed with the Hawaii Public Utilities commission on 2021 Aug 03 PM 16:21. The mere fact of filing shall not waive any failure to comply with Hawaii Administrative Rules Chapter 6-61, Rules of Practice and Procedure Before the Public Utilities Commission, or any other application requirements. Your confirmation number is MARI21162150621. If you have received this email in error please notify the Hawaii Public Utilities Commission by phone at 808 586-2020 or email at [hawaii.puc@hawaii.gov](mailto:hawaii.puc@hawaii.gov).