

REGULATORY OPERATIONS



Westinghouse Electric Corporation

Power Systems

Water Reactor Divisions

Box 355
Pittsburgh Pennsylvania 15230

April 6, 1973

U. S. Atomic Energy Commission
Directorate of Licensing
Washington, D. C. 20545

Attention: Mr. Charles E. MacDonald, Chief
Transportation Branch

Gentlemen:

Subject: Application for Amendment of License SNM-338, ,
Docket 70-337, to Authorize Use of NFD Shipping
Packages

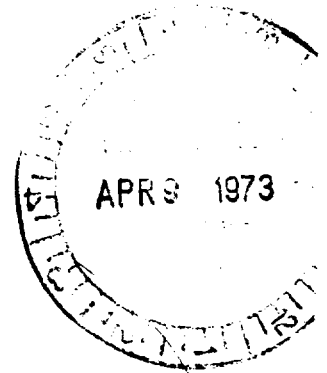

The Westinghouse Electric Corporation hereby requests amendment of the subject license to authorize the delivery of special nuclear material to a carrier for transport in the Model CC Shipping Package described in the attachment to this letter. Please note that this application revises the parameters associated with fuel assembly shipping, only. This change is not intended to affect the authorization which currently exists under Amendment 71-10.

Please send the amended license to me at the above address.

If you have any questions, please write to me at the above address or telephone me collect (412) 373-4652.

Very truly yours,

Karl R. Schendel
License Administrator

KRS:jh

Attachment

ITEM # 236

C/236

17

2321

FILING INSTRUCTIONS

The transmittal letter should be filed in the binder labelled "Application for Amendment of License SNM-338 for NFD Shipping Package" immediately in front of the transmittal letter dated February 25, 1972.

Revised pages 7.3 and Appendix B should be inserted and the old pages removed.

The new report, CC Package Nuclear Criticality Safety Model should be inserted immediately following the previous Safety Model in Appendix B.

The removed pages may be filed in the back of the binder.

Revision No. 30
April 6, 1973

Revision Record (continued)

| <u>Revision No.</u> | <u>Date of Revision</u> | <u>Pages Revised</u> | <u>Revision Reason</u> |
|---------------------|-------------------------|----------------------|---|
| 26 | 7/23/71 | 60, 60.1 | Added discussion of structural adequacy of MIL inner can. |
| 26 | 7/23/71 | 62 | Editorial corrections. |
| 26 | 7/23/71 | 64 - 66 | Added results of Super KENO calculation |
| 26 | 7/23/71 | Appendix R | Added MS-24347 |
| 27 | 9/3/71 | 65 | H/U of 1.5 was 0.5 |
| 27 | 9/3/71 | Appendix R | Added "Single Package Evaluation" and Figures 2 thru 9. |
| 28 | 10/8/71 | 18 | Updated LEOPARD reference |
| 28 | 10/8/71 | 19 | .500 inches was .444 |
| 28 | 10/8/71 | Appendix B | Added 14 X 14 Assembly with 4.5 w/o enrichment. Also added safety model report. |
| 29 | 2/25/72 | 53 - 55 | Added provisions for shipping loose rods. |
| 29 | 2/25/72 | 55.1 | New |
| 29 | 2/25/72 | Appendix P | Added rod shipping nuclear criticality safety model. |
| 30 | 4/6/73 | Appendix B | For 15X15 Ass'y increase enrich. to 4.5 w/o enrichment. Total U-235 to 30 kg. Added calculations. |

Appendix B

Products Shipped in Type CC Packages

| Type | 14 X 14 SST Clad Assemblies | 15 X 15 SST Clad Assemblies | 14 X 14 SST Clad Assemblies |
|------------------------------|--------------------------------|--------------------------------|--------------------------------|
| Pellet Parameters | | | |
| Material | UO ₂ | UO ₂ | UO ₂ |
| Highest Enrichment (Nom) | 4.1 w/o | 4.5 w/o | 4.5 w/o |
| Diameter (Nom) | 0.317" | 0.355" | 0.313" |
| Rod Parameters | | | |
| Cladding Mt'l | SST | SST | SST |
| Diameter (Nom) | 0.341" | 0.385" | 0.341" |
| Fuel Lgth (Nom) | 105" | 106" | 90" |
| Assy. Parameters | | | |
| No. of rods (Max) | 173 | 208 | 173 |
| Pattern (Basic) | 14 X 14 sq | 15 X 15 sq | 14 X 14 sq |
| Lattice Pitch (Nom) | 0.453" | 0.513" | 0.453" |
| Outside Dimen. (Nom) | 6.284" | 7.695" | 6.284" |
| Licensing Criteria | | | |
| Total U-235 (Max/pkg) | 20 kg | 30 kg | 20 kg |
| k _{eff} (Max/ass'y) | 0.74 | 0.86 | 0.78 |
| k _{eff} (Max/1 pkg) | 0.84 | 0.90 | 0.84 |
| k _{eff} (Max/MCA) | 0.98 | 0.98 | 0.98 |
| Poison Pl. Req'd | N.A. | N.A. | N.A. |
| Net Wt. of Contents (Max) | 2000# | 2200# | 2000# |

1. INTRODUCTION

These calculations are in support of an application for an AEC license to ship cruciform core SS clad, SS can uranium assemblies enriched up to 4.5w/o. It is concluded that such assemblies can be safely shipped. A more detailed description of the assembly design is given below, together with details of the calculations performed and their results.

2. ASSEMBLY DESCRIPTION AND ASSUMPTIONS

A cross-section of the assembly appears in Figure 1. There are eleven thick clad rods in corners as shown in the figure. The average rod pitch is .518", the maximum fuel enrichment, 4.5w/o and the density, 95% of theoretical.

The shipping container in which the fuel will be shipped is described in the following Champion Company, Springfield, Ohio, drawings:

| Drawing No. | Title |
|-------------|---------------------------------------|
| 10410 | Container'- Shipping, Reusable, Metal |
| 10541 | Mounting Assembly Bottom |
| 10536 | Bottom Assembly (two sheets) |
| 10538 | Top Weldment (three sheets) |

The manner of placing the two assemblies in each container is such that the sides of the assembly that are recessed to accommodate the cruciform rods, are away from each other as shown in Figure 2. The assemblies have been represented in the spatial x-y calculations accordingly.

The following assumptions have been made which are all conservative from the standpoint of criticality safety:

- The assemblies have been assumed to be of infinite length i.e., they have a zero axial buckling.
- None of the structural material of the cask has been included in the calculations, except the wall thickness in the maximum credible accident (MCA).
- As the fuel is under-moderated in the assembly design, the density of the water has been assumed to be at its maximum value of 1.0 gms/cc.

3. CALCULATIONAL MODEL

Calculations were performed using modified versions of the LEOPARD and PDQ03 codes. The PDQ03 calculations were performed for each of the following cases:

- A single assembly, flooded.
- Two assemblies in a shipping cask, flooded.
- Two shipping casks crushed together and flooded - the MCA. The two assemblies in each cask are assumed to remain intact and separated by their usual distance. The casks are assumed to be crushed together so that both pairs of assemblies are perfectly aligned opposite each other. Only the wall thickness of the two casks are assumed to lie in between the pairs of assemblies. The two pairs of assemblies are then assumed to be separated by that distance which gives the highest multiplication factor.

The geometry, mesh intervals and boundary conditions used in the PDQ03 calculations for each of the above three cases are shown in Figures 3 through 5 respectively.

For the MCA the distance separating the two pairs of assemblies was varied to determine that which gives the maximum multiplication factor. Calculations were performed at the separations of .324", .384", .5", 1" and 2". Initially no cask wall steel was placed in between. The .384" separation gave the highest multiplication. Cask wall steel was then inserted in this case.

4. CALCULATIONAL RESULTS

The results of the above calculations are tabulated in Table 1.

A plot of K_{eff} as a function of the distance separating the two pairs of assemblies in the MCA appears in Figure 6.

The criticality safety criteria for the single assembly flooded and the two assemblies in the cask, flooded, is a K_{eff} of $\leq .90$. For the MCA, with cask wall steel included, the required K_{eff} is $\leq .98$. The corresponding K_{eff} values obtained in the calculations appear at Serial Nos. 1, 2 and 8 respectively, in Table 1. They are all below the criteria and therefore

the package is safe for shipment.

The following additional information is included:

Atom Densities

Table 2

Macroscopic Cross-sections

Table 3

5. CONCLUSIONS

Cruciform core SS clad, SS can uranium fuel as described in this report and enriched up to 4.5w/o can be safely shipped in the Champion Company shipping container.

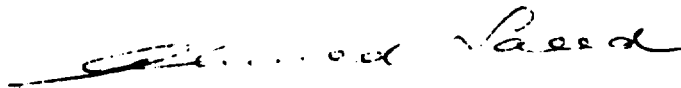

A. Saeed

Table 1

Multiplication Factors

| <u>Serial No.</u> | <u>Case</u> | <u>K_{eff}</u> |
|-------------------|--|------------------------|
| 1 | Single assembly flooded | .8109 |
| 2 | Two assemblies in cask flooded | .8642 |
| 3 | MCA (two pairs of assemblies in two casks crushed together) with no cask wall steel in between. Separation between pairs of .324". | .9996 |
| 4 | Same as 3 with .384" separation | 1.00228 |
| 5 | Same as 3 with .5" separation | 1.00195 |
| 6 | Same as 3 with 1" separation | .9936 |
| 7 | Same as 3 with 2" separation | .9583 |
| 8 | Same as Serial No. 4 with cask wall steel in between | .9712 |

Table 2

Atom Densities
(Atoms/cc, 10^{24} units)

| Element | Flooded Fuel Assembly, 4.5w/o | Water | Steel |
|-----------------|----------------------------------|--------|-------|
| Hydrogen | .03800 | .06688 | |
| Oxygen | .03439 | .03344 | |
| Zircaloy | .0001513 | | |
| Stainless Steel | .007299 | | .0897 |
| U-234 | .000002854 | | |
| U-235 | .0003506 | | |
| U-236 | .000002184 | | |
| U-238 | .007342 | | |

Table 3

Macroscopic Cross-Sections
(Temperature = 60°F, Water density used = 1.0 gms/cc)

| Cross-Section | Flooded Fuel Assembly, 4.5w/o | Water | Steel |
|-----------------------------------|----------------------------------|----------|---------|
| <u>Group 1</u> | | | |
| D (cm) | 1.1306 | 1.2855 | 1.18 |
| Σ_a (cm ⁻¹) | .01119 | .0004409 | .00055 |
| Σ_R (cm ⁻¹) | .02146 | .04888 | .000331 |
| $\nu\Sigma_f$ (cm ⁻¹) | .009583 | | |
| <u>Group 2</u> | | | |
| D (cm) | .2077 | .1642 | .337 |
| Σ_a (cm ⁻¹) | .2353 | .0222 | .22 |
| $\nu\Sigma_f$ (cm ⁻¹) | .3796 | | |

Table 4

MCA - Row Mesh Intervals
 From Row 27 through Row Boundary
 (Applies to Figure 5)

| Separation Between Pairs of Assemblies Inches | Boundary Row No. | Mesh Intervals Row 27 through Row Boundary, cm |
|---|---------------------|--|
| .324 | 28 | .4115 |
| .384 | 29 | .0762, .4115 |
| .5 | 29 | .2235, .4115 |
| 1.0 | 30 | .4293, .4293, .4115 |
| 2.0 | 31 | .7095, .7095, .7095, .4115 |

NOTE: The .4115 cm distance represents half the thickness of the cask wall steel between the two pairs of assemblies.

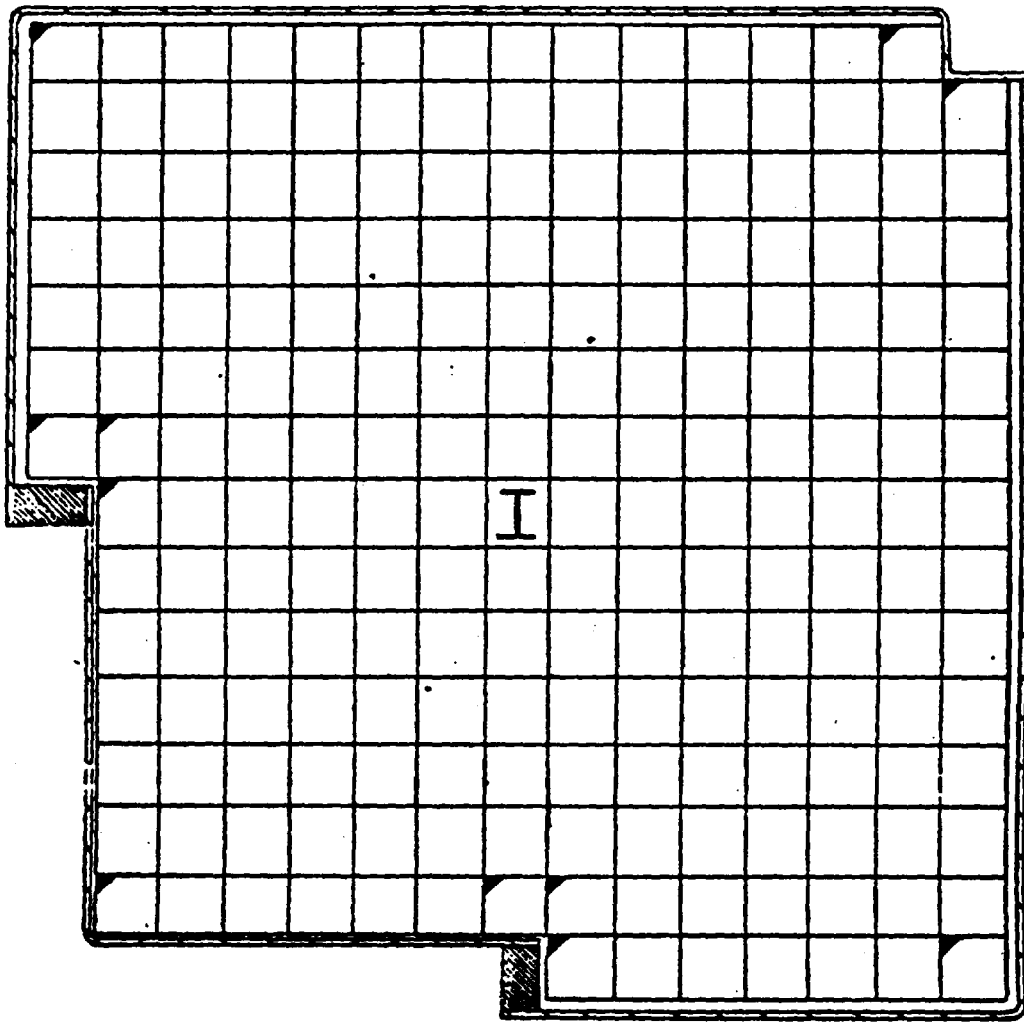

LEGEND:



INSTRUMENT WATER HOLE



THICK CLAD RODS.
24 MIL THICK WALLS



Zr FILLER BAR



THIN CLAD RODS



SS CAN AROUND ASSEMBLY

Figure 1 Assembly Regular and Thick Clad Rod Pattern

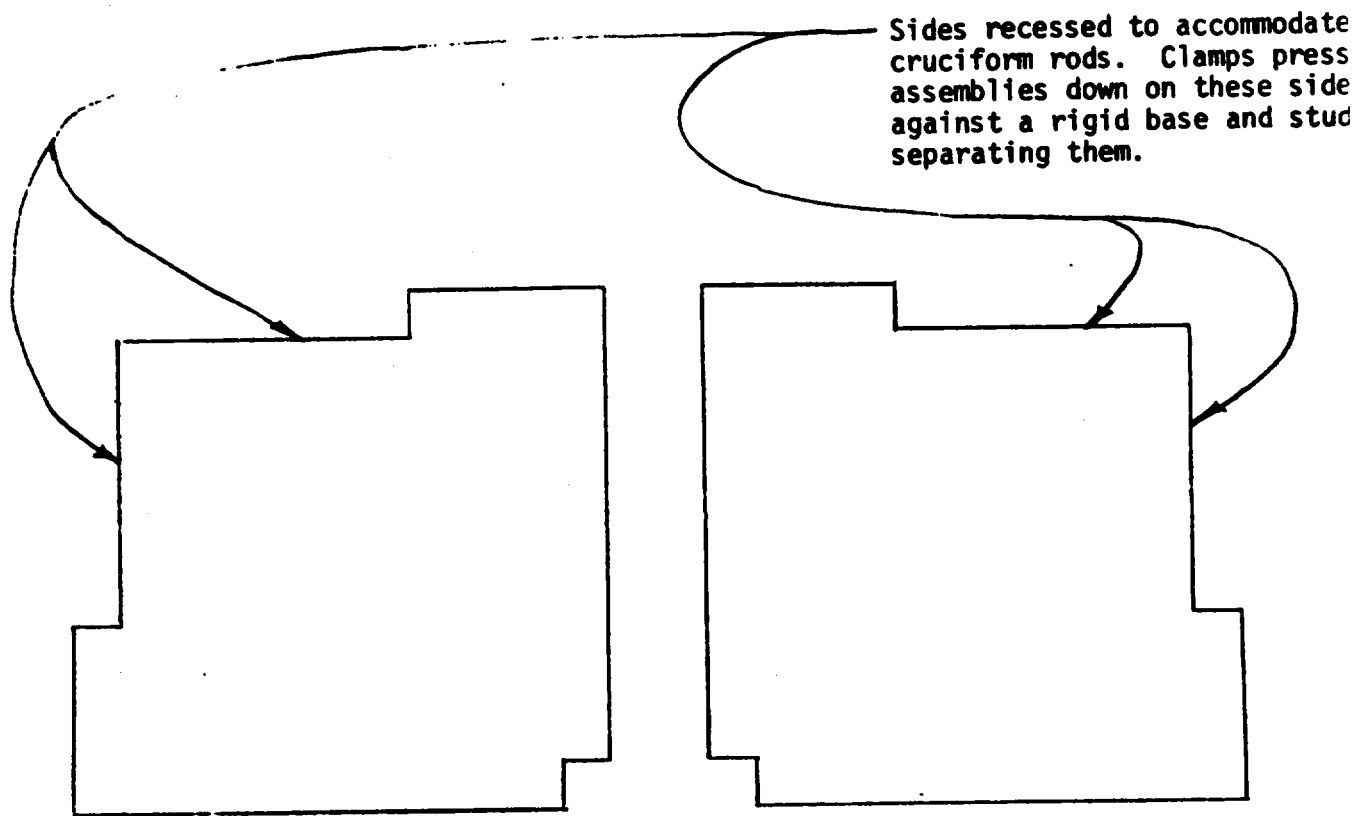
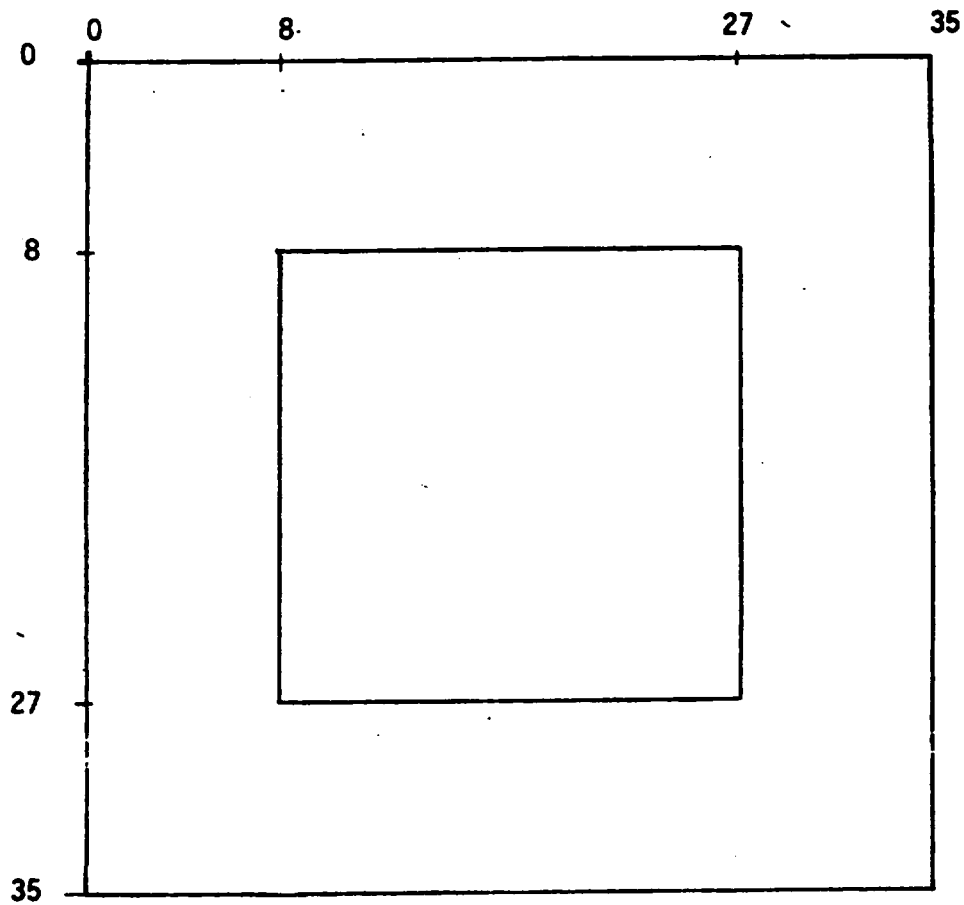

Figure 2 Manner of Placing Cruciform Assemblies in Shipping Container



Boundary conditions: Zero flux on all four sides.

Column mesh intervals in cm:

Columns 0 thru 8; reflector: 3.0, 3.0, 3.0, 3.0, 3.0, 2.0, 1.0, .5

Columns 8 thru 27; assembly: .1791, 1.0922, .2235, 13 times 1.3157, .2235,
1.0922, .1791

Columns 27 thru 35; reflector: same as columns 0 thru 8 in reverse

Row mesh intervals: same as column mesh intervals

Figure 3 Geometry and Mesh Intervals for a Single Assembly Flooded

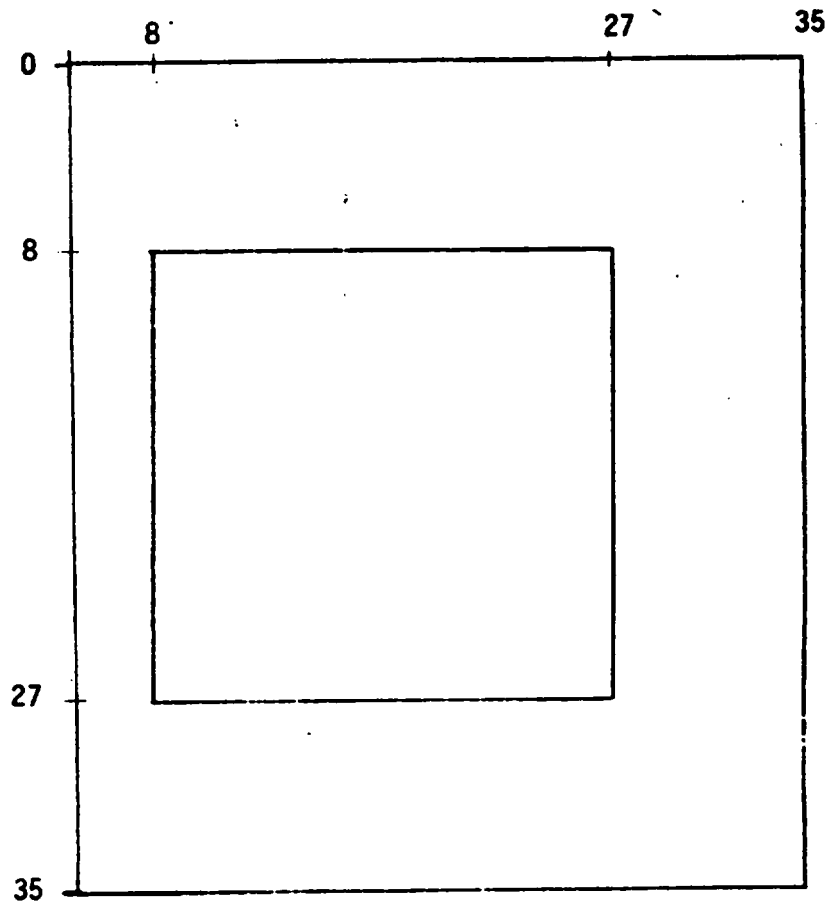

Boundary conditions: Zero current on left, Zero flux on the remaining three sides

Column mesh intervals in cm:

Columns 0 thru 8: gap between the two assemblies in cask, .51, .51, .51, .51
.51, .51, .50, .25

Columns 8 thru 35, assembly and reflector: same as for columns 8 thru 35
in Figure 3

Row mesh intervals: same as in Figure 3

Figure 4 Geometry and Mesh Intervals for Two Assemblies in Cask Flooded

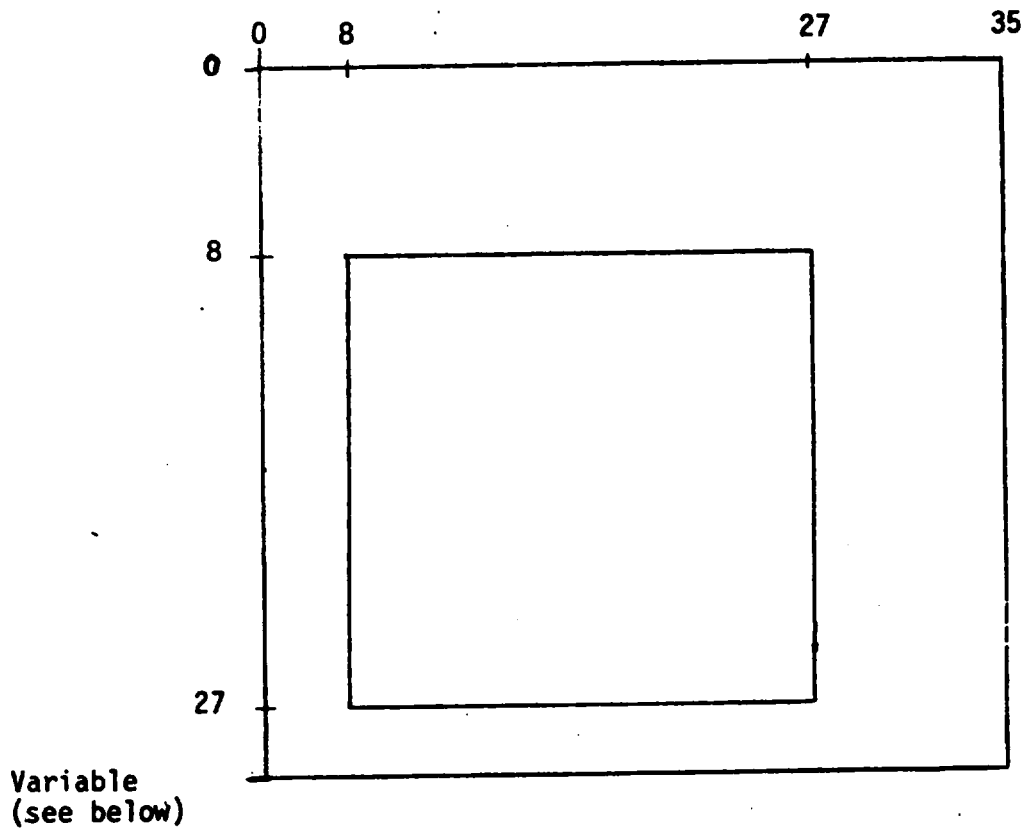

Boundary conditions: Zero current on left and lower sides, Zero flux on remaining two sides

Column mesh intervals: Same as in Figure 4

Row mesh intervals in cm: Row 0 thru 27, same as in Figure 3
Row 27 thru row boundary, see Table 4

Figure 5 Geometry and Mesh Intervals for the MCA

Curve A K_{eff} for the two pairs of assemblies in two casks in the MCA configuration without any steel in between the pairs.

Point B Same with the cask wall steel of the two casks in between the pairs of assemblies.

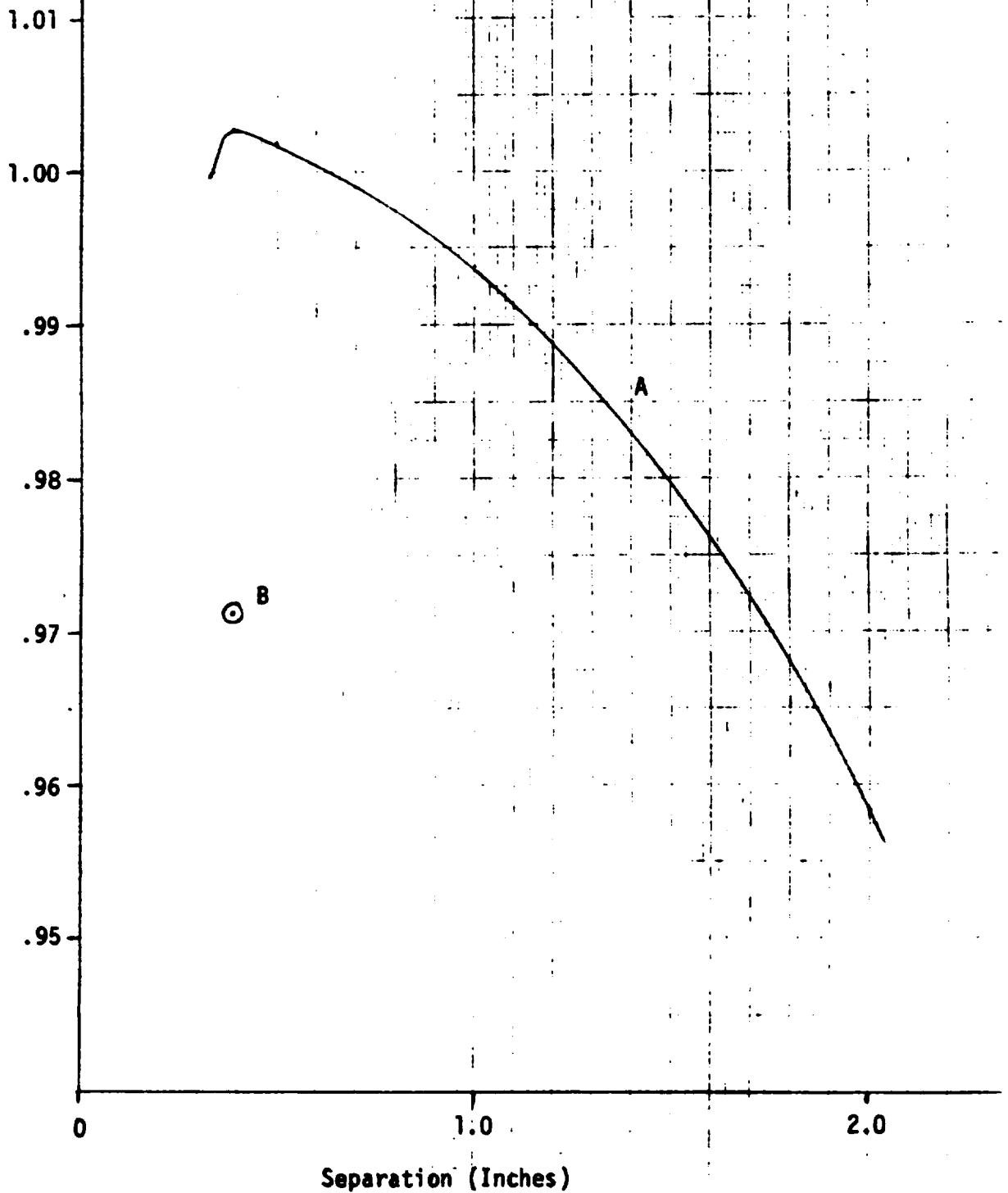

Figure 6 K_{eff} as a Function of Separation Between Pairs of Assemblies in the MCA

1. LICENSEE: Westinghouse Electric Corporation DOCKET NO. 70-337 PRIORITY AND/OR CATEGORY A-I
 FACILITY: Cheswick, Pennsylvania LICENSE NO. SNM-338
 REGION MAKING INSPECTION: CO:I INSPECTOR: Walter R. Lorenz

INSPECTION DATES: FROM XXXX TO XX REPORT NO.: _____

2. TYPE OF REPORT: INSP: () INIT, () REINSP; () INVEST; INQUIRY; () VENDOR.

3. REPORT ACTION: () CLEAR; () DRL/DML FOR INFO; () 592; () CDN; () HQS FOR ACTION.

4. CHARACTER OF ENFORCEMENT ACTION: () SAFETY ITEM; () NONCONFORMANCE;
 () NONCOMPLIANCE - W/LIC COND _____ IOCFR _____

5. FIELD ACTION AS A RESULT OF INQUIRY: () CONDUCT INVESTIGATION; REVIEW NEXT INSP.;
 () REFER TO _____ ; () NO FURTHER ACTION.

| 6. A | B | C |
|--|--|--|
| <p><u>REASON INSP. REPORT TO HQS FOR ACTION:</u></p> <ul style="list-style-type: none"> () IMMED. THREAT TO H & S COMPLEX ITEM INVOLVING: <ul style="list-style-type: none"> () NONCOMPLIANCE () LICENSING PROBLEM () POLICY MATTER () INTERPRETATION () SAFETY ITEM () COSTLY TO CORRECT () >180 DAYS TO CORRECT () UNCORRECTED N/C () NO CORRECTIVE ACTION PLANNED () INADEQ. CORRECT ACTION PLANNED () 592, CDN NO REPLY RECEIVED () 592, CDN INADEQ REPLY () UNREVIEWED SAFETY ITEM () DESIGN CHANGE W/O DRL APPR. () APPROPRIATE FOR HQS ACTION () DISCRETION OF REG. OFFICE () REVIEW () OTHER | <p><u>SUBJECT OF INQUIRY OR INVESTIGATION:</u></p> <p>TYPE () A, () B</p> <ul style="list-style-type: none"> () OVEREXPOSURE <ul style="list-style-type: none"> () INT () EXT () RELEASE () LOSS OF FACILITY () PROPERTY DAMAGE 10 CFR 20.405 <input checked="" type="checkbox"/> OVEREXPOSURE <ul style="list-style-type: none"> () INT () EXT () EXCESSIVE RAD LEVELS () EXCESSIVE CONC LEVELS () CRITICALITY () LOSS OR THEFT () CONTAMINATION () UNSAFE OPERATION () FIRE, EXPLOSION () HUMAN/OPERATOR ERROR () COMPLAINT () PUBLIC INTEREST () LEAKING SOURCE () TRANSPORTATION () EXPIRED LICENSE () OTHER | <p><u>HQS ACTION ON INSPECT. AND INVEST. REPORTS:</u></p> <ul style="list-style-type: none"> () NO ACTION () LETTER - CLEAR () LETTER - N/C () LETTER - SAFETY ITEM () PART 2 NOTICE () PART 2 NOTICE AS RESULT OF FOLLOWUP TO 592, CDN () ORDER () LICENSE AMENDMENT () ENFORCEMENT VISIT () APPLICATION DENIAL () REFER TO DRL FOR RESOLUTION () REFER TO DRL FOR INFORMATION () OTHER () EXPOSURE REPORTED AND FOUND INVALID () CONST./EQUIP. DEFICIENCY () EQUIPMENT FAILURE () EXCEED LIC/TECH SPEC REQ'S () DEPARTURE FROM FSAR/TS'S |

7. REGIONAL OFFICE ACTION DATES:
 ISSUE 592 OR CDN _____
 TRANSMIT REPORT TO HQS JAN 25 1971
 RECEIVE LICENSEE REPLY _____

8. HQS ACTION DATES:
 ISSUE NOTICE, ORDER _____
 FORWARD REPORT _____
 RECEIVE LICENSEE REPLY _____

9. CHARACTER OF LICENSEE REPLY: () ADEQ () INADEQ () NOT REQUIRED.

10. COMMENTS: _____

ITEM # 237

9/237

JAN 25 1971

Gen W. Roy, Chief, Materials and Fuels Facilities Branch,
Division of Compliance, Headquarters

COMPLIANCE INQUIRY MEMORANDUM
WESTINGHOUSE ELECTRIC CORPORATION
CHESWICK, PENNSYLVANIA
LICENSE NO. SNM-338
DOCKET NO. 70-337
PERSONNEL EXPOSURES TO EXCESSIVE AIR CONCENTRATIONS

On January 18, 1971, CO:I received a copy of a letter from the subject licensee to the Director, Division of Compliance dated January 12, 1971, reporting the exposure of personnel to air concentrations of 3 - 5% enriched uranium in excess of that permitted by 20.103. According to the letter, eight persons were overexposed. All persons were reportedly informed of their exposure as required by 20.405.

According to the licensee's letter six of the eight exposures occurred while personnel operated the Cincinnati Grinder, the remaining exposures while operating a Royal Grinder. The exposures occurred during the week of December 7 - 11, 1970. Past inspection reports have noted that these centerless grinders, particularly the Cincinnati Grinders, are potential sources for such exposures. According to information contained in the inspection report of the November 23 - 25, 1970 inspection, the licensee plans to replace the Cincinnati Grinders because of this hazard.

From the information contained in the report dated January 12, 1971, appropriate interim action is being taken to prevent a recurrence. This incident will be reviewed during the next scheduled inspection of the license.

H. W. Crocker
Senior Fuel Facilities Inspector

cc: A. Giambusso, CO
L. Kornblith, CO
R. Engelken, CO

ITEM # 238

| | | | | | |
|-----------|-------------------------|----------------------|-----------|--|--|
| OFFICE ▶ | COMPLIANCE | | | | |
| SURNAME ▶ | <i>Lorenz</i> Lorenz | <i>HW</i> Crocker | <i>CR</i> | | |
| DATE ▶ | 1/22/71 | 1/25/71 | 1/22/71 | | |

C/238

Westinghouse Electric Corporation

Power Systems

DOCKET

NO.

SNM-338
70-337

PWR Systems Division

Box 355
Pittsburgh Pennsylvania 15230

For Div. of Compliance

March 22, 1971

U. S. Atomic Energy Commission
Washington, D. C. 20545

Attention: Mr. L. E. Johnson, Acting Director
Division of Materials Licensing

Dr. P. A. Morris, Director
Division of Reactor Licensing

Gentlemen:

Subject: Change of Address

All of the licenses on the attached list are centrally administered by me as License Administrator. This letter is to request that all correspondence from the Commission regarding any of these licenses be addressed to me using the following address:

Westinghouse Electric Corporation
Monroeville Nuclear Center
P. O. Box 355
Pittsburgh, Pa. 15230

Attn: Karl R. Schendel

I am providing a sufficient number of copies of this request so that a copy can be placed in each license file or docket.

Please notice that this request does not involve any formal revision either of the licensee or the location where the material will be used. The revised address will expedite correspondence by routing it to me more directly.

If you have any questions, please write to me at the indicated address, or telephone me collect at (412) 373-4652.

Very truly yours,

Karl R. Schendel

Karl R. Schendel
License Administrator

KRS:jh

Attachment: Current List of Licenses
30 copies transmitted

ITEM # 240 1448

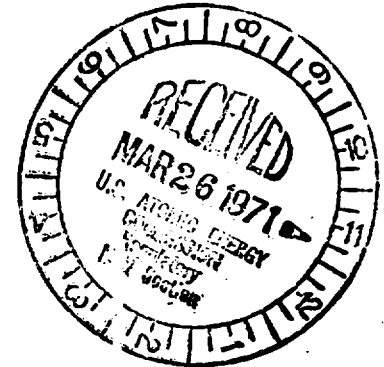

CURRENT LIST OF LICENSES

| <u>Users and Site</u> | <u>License Numbers</u> |
|--|--|
| Nuclear Energy Systems Cheswick | SNM-338, 1120; 1170 37-05809-01, 37-05809-02 SMB-355 |
| Columbia, S.C. | SNM-1107 |
| Forest Hills | 37-00497-09 |
| Waltz Mill | SNM-576, 738, 770; CX-11; 37-09442-04; TR-2 |
| Astronuclear Laboratories Cheswick | 37-05809-03 |
| Large | SNM-951; 37-09442-02; SMB-915 |
| Waltz Mill | 37-09442-01 |
| Research Laboratories Churchill | SNM-47; 37-00497-06; SMB-550. |
| Headquarters Industrial Hygiene Laboratory East Pittsburgh | 37-00497-13 |
| Semiconductor Division Youngwood | 37-07934-01 |

XXXXXXXXXXXXXXXXXXXX
 XXXXXXXXXXXXXXXXXXXX
 631 Park Avenue
 King of Prussia, Pennsylvania 19406

November 21, 1973

Westinghouse Electric Corporation
 Attention: Mr. Theodore Stern
 Vice President and General Manager
 Water Reactors Division
 P. O. Box 355
 Pittsburgh, Pennsylvania 15230

Docket No. 70-337
 License No. SNM-338

Gentlemen:

This refers to the inspection conducted by Mr. Della Ratta of this office on October 30, 1973 - November 1, 1973 of activities authorized by AEC License No. SNM-338 and to the discussions of our findings held by Mr. Della Ratta with Mr. A. T. Sabo and Mr. R. E. Tschiegg at the conclusion of the inspection.

Areas examined during this inspection included: records, reports, and a verification of the reconciliation to a zero balance of material and ledger accounts. Within these areas, the inspection consisted of selective examinations of procedures and representative records and observations by the inspector.

~~Within the scope of this inspection, no violations were observed.~~

No reply to this letter is required; however, if you should have any questions concerning this inspection, we will be pleased to discuss them with you.

Sincerely,

signed

Walter G. Martin, Chief
 Materials and Plant Protection
 Branch

- bcc: RO Chief, FS&EB, HQ (w cy of Rpt)
- RO: Chief Materials & Plant Protection Br, HQ (w cy of Rpt)
- RO: HQ (4) (w cys of Rpt)
- Directorate of Licensing, HQ (4) (w cys of Rpt)
- DR Central Files (w cy of Rpt)
- PDR (w/o cy of Rpt)
- Local PDR (w/o cy of Rpt)
- State of Pennsylvania (w/o cy of Rpt)
- RO: HQ Files (w cy of Rpt)
- RO: I M&PPB (2) (w cys of Rpt)

C1240

ITEM # 241

(6)

| | | | | | |
|-----------|--------------------|------------------|---------------|---------------|--|
| OFFICE ▶ | CRESS | | | | |
| SURNAME ▶ | <i>Della Ratta</i> | <i>Gundersen</i> | <i>Martin</i> | <i>Reilly</i> | |
| DATE ▶ | 11/19/73 | 11/19/73 | 11/19/73 | 11/ /73 | |

OFFICIAL USE ONLY
NOT FOR PUBLIC DISCLOSURE
U.S. ATOMIC ENERGY COMMISSION

DIRECTORATE OF REGULATORY OPERATIONS

REGION I

RO Inspection Report No.: RO:I-70-337-WNFD-MAPP-74-1

Docket No.: 70-337

Licensee: Westinghouse Electric Corporation

License No.: SNM-338

NFD

- Priority: 1

Category: _____

Location: Cheswick, Pennsylvania

Type of Licensee: Fuel Fabricator

Type of Inspection: Announced

Dates of Inspection: An October 30-November 1, 1973

Dates of Previous Inspection: October 24, 1970 - October 13, 1971

Inspection Period Covered: October 14, 1971 - September 30, 1973

Reporting Inspector: A. Della Ratta
A. Della Ratta

11/15/73
Date

Accompanying Inspectors: Gordon E. Anderson

11/19/73
Date

_____ Date

_____ Date

_____ Date

Other Accompanying Personnel: _____

_____ Date

Reviewed by: W. G. Martin
W. G. Martin, Chief, Materials and Plant Protection Branch

11/19/73
Date

_____ Date

OFFICIAL USE ONLY
NOT FOR PUBLIC DISCLOSURE

A. Summary of Findings

A close out inspection was performed on Westinghouse Electric Corporation, NFD, License No. SNM-338, Docket No. 70-337. The Nuclear Fuel Division has terminated their special nuclear material operation and all nuclear material has been removed from the premises.

The previous inspection report, No. SO-I-54 dated January 10, 1972, cited Westinghouse Electric Corporation for certain activities that were not conducted in full compliance with the requirements of Title 10, Code of Federal Regulations, Part 70.54. Westinghouse Electric Corporation's letter dated March 17, 1972 and our responding letter dated April 26, 1972 covered the corrective actions to be taken in regard to the above. The results of the corrective actions were acceptable and/or the condition eliminated due to termination of operation.

A program deficiency was noted under the licensee Condition No. 1.5. The licensee concurred with our finding and agreed to correct the deficiency.

B. Report Details

1. Individuals Contacted

A. T. Sabo, Director of Industrial Hygiene and Safety
R. E. Tschiegg, Manager, Nuclear Material Management and Safeguards
K. R. Schendel, License Administrator

2. Introduction

Westinghouse Electric Corporation, Nuclear Fuel Division has since our last prior inspection of October, 1971, terminated their special nuclear material operations. The final shipment of all the nuclear material to Beznau, Switzerland was completed on March 13, 1973. The disposal of the processing equipment has essentially been completed and the areas decontaminated.

3. Scope

The inspection covered an audit of accounts, records, supporting documents and reports from October 14, 1971 to September 30, 1973 and a verification of the reconciliation of the book balance to a -0- physical inventory as shown in Schedules I & II, attached. During our inspection, a Radiation Specialist from our Radiological and Environmental Protection Branch was performing an inspection on what previously had been the storage, process and laboratory areas and noted that there was no evidence of nuclear material on hand.

4. Discussion of Findings

1. The licensee was informed that there was no items of noncompliance as a result of this inspection.

OFFICIAL USE ONLY

OFFICIAL USE ONLY
NOT FOR PUBLIC DISCLOSURE

-2-

2. The licensee Condition No. 1.5 states that "All delegations of safeguards responsibilities by the Safeguards Manager shall be in writing". Our review of the licensee's AEC-741's disclosed several instances whereby the Safeguards Manager had verbally authorized certain employees to sign the AEC-741 in his behalf without spelling out this redelegation of authority in writing. The licensee agreed to correct this program deficiency.

OFFICIAL USE ONLY
NOT FOR PUBLIC DISCLOSURE

OFFICIAL USE ONLY
NOT FOR PUBLIC DISCLOSURE

WESTINGHOUSE CORPORATION
NFD
Cheswick, Pa.

SCHEDULE I

MATERIAL ACTIVITY COVERING
10/14/71 - 9/30/73

| | <u>ENRICHED URANIUM</u> | |
|--------------------------------|-------------------------|----------------|
| | <u>U</u> | <u>ZYP</u> |
| | | <u>U-235</u> |
| Beginning Inventory - 10/14/71 | 103680414 | 2809628 |
| Receipts | <u>171952713</u> | <u>5699675</u> |
| Material To Account For | 275633127 | 8509303 |
| <u>Removals</u> | | |
| Shipments | 274248435 | 8464191 |
| Normal Operational Loss | 144669 | 5044 |
| Material Unaccounted For | 1240023 | 40068 |
| Inventory - 9/30/73 | <u>- 0 -</u> | <u>- 0 -</u> |
| Material Accounted For | 275633127 | 8509303 |

OFFICIAL USE ONLY
NOT FOR PUBLIC DISCLOSURE

OFFICIAL USE ONLY
NOT FOR PUBLIC DISCLOSURE

WESTINGHOUSE CORPORATION
NFD
Cheswick, Pa.

SCHEDULE II

MATERIAL ACTIVITY COVERING
10/14/71 - 9/30/73

| | <u>PLUTONIUM</u> | |
|--------------------------------|------------------------|------------|
| | <u>ZYP</u> | |
| | <u>ELEMENT ISOTOPE</u> | |
| Beginning Inventory - 10/14/71 | 1228 | 1122 |
| Receipts | <u>-0-</u> | <u>-0-</u> |
| Material To Account For | 1228 | 1122 |
| Removals | | |
| Shipments | 1228 | 1122 |
| Normal Operational Loss | -0- | -0- |
| Material Unaccounted For | -0- | -0- |
| Inventory - 9/30/73 | <u>-0-</u> | <u>-0-</u> |
| Material Accounted For | 1228 | 1122 |

OFFICIAL USE ONLY
NOT FOR PUBLIC DISCLOSURE



Westinghouse Electric Corporation

Power Systems

PWR Systems Division

For Dir. of Compliance

Box 355

Pittsburgh Pennsylvania 15230

April 18, 1972

U. S. Atomic Energy Commission
Washington, D. C. 20545

Attention: Mr. S. H. Smiley, Director
Division of Materials Licensing

Dr. P. A. Morris, Director
Division of Reactor Licensing

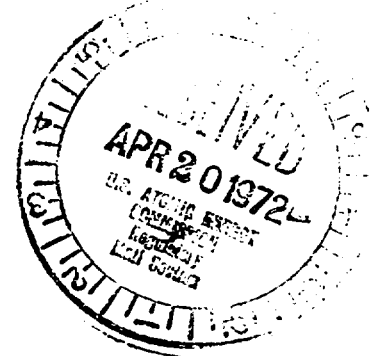

Gentlemen:

Subject: Corporate Information for Licenses

The Westinghouse Electric Corporation hereby submits current information applicable to the USAEC Licenses listed at the end of this letter which have been issued to the Corporation. Corporate information was originally sent to you in a letter addressed to Mr. R. W. Lowenstein, Assistant Director of Regulations, dated April 3, 1964, and thereafter has been updated at least annually. The last previous letter, dated April 28, 1971, was transmitted jointly to Mr. L. E. Johnson (then Acting Director of DML) and Dr. Morris.

The Westinghouse Electric Corporation is incorporated in the Commonwealth of Pennsylvania, with principal offices located in the Westinghouse Building, Gateway Center, Pittsburgh, Pennsylvania 15222. All of the Directors and Officers are citizens of the United States of America.

Westinghouse is a publicly held corporation whose stock is traded on principal securities exchanges. It is not owned, nor is there (to the best of our knowledge) an appreciable ownership of Westinghouse stock, by an alien, foreign corporation or foreign government. No individual is known, from the records of the Corporation, to own one percent or more of its capital stock.

ITEM # 242

c/242

(5)

2435

COPY SENT REGION

H

April 18, 1972

Westinghouse has entered into Lease Agreements Nos. 245 and 2003 with the U. S. Atomic Energy Commission.

Attached is the annual report of the Corporation which gives the current financial condition and lists the elected officers. The following section of this letter presents a description of corporation technical qualifications.

The Westinghouse Electric Corporation has broad experience in the field of nuclear science and technology. The Corporation's participation in the nuclear energy field dates from the discovery of methods for the production of metallic uranium at Bloomfield, New Jersey, in the 1920's and construction of the first industrial Van de Graaf generator in Pittsburgh in 1937. Westinghouse furnished a portion of the refined metallic uranium used in the first pile at Stagg Field, Chicago, early in the 1940's, at the beginning of the Manhattan District of the Corps of Engineers.

Westinghouse demonstrated the ability to execute complex programs leading to the practical application of nuclear energy with the successful completion of the reactor plant for the first nuclear powered submarine, the U.S.S. NAUTILUS. In conjunction with this project, the Bettis Atomic Power Laboratory was organized in 1948 to furnish a research and development effort. This Laboratory, which provides facilities for developing nuclear power plants for naval and advanced civilian applications, is currently being operated by Westinghouse for the AEC. The AEC also awarded Westinghouse the contract for the design and construction of the nation's first large nuclear reactor plant for an electric power generating station, the Shippingport Atomic Power Station. Other projects include a minimum of fifteen completed power reactors including the nuclear power plant for the Yankee Atomic Electric Company, a 185 MWe closed-cycle pressurized water reactor which has generated approximately twelve billion kilowatt-hours of electricity; the Saxton Reactor, a 23.5 MWe experimental closed-cycle water reactor which is currently operating on an advanced plutonium-uranium based fuel; and the second-generation Connecticut Yankee Atomic Power Co. plant, a 490 MWe pressurized water reactor which was the first of the large, economically competitive reactors. Currently, the Corporation is designing or building fifty-six large reactor facilities, ranging in size from 350 MWe to 1220 MWe, with a total generating capacity in excess of 50,000 MWe. In addition, the fabrication of replacement regions for operating reactors is a significant activity.

The Corporation holds the contract to provide the project management, design, and test services for the Fast Flux Test Facility, which will be used in the testing and evaluation of fuels and materials for the USAEC's Liquid Metal Fast Breeder Reactor program.

Westinghouse has been a leader in the development of nuclear propulsion and auxiliary power equipment for space applications. The Westinghouse Astronuclear Laboratory developed and fabricated nuclear reactors for the NERVA program. The Laboratory still is participating in the development of the SNAP-23A package and compact thermoelectric converters for the AEC.

Various divisions of the Corporation have demonstrated other major accomplishments in the nuclear energy field. Westinghouse developed canned motor and controlled leakage pumps, currently being manufactured for a variety of nuclear facilities, and it also manufactures many other non-nuclear components for reactor plants such as large heat exchangers, control rod drive mechanisms, valves, instrumentation and control equipment.

Westinghouse maintains a number of design and development groups in the Pittsburgh area (over 3,000 engineers and scientists) that contribute to these accomplishments in the nuclear field. There is an accident prevention administrator and a medical services administrator located at the Gateway Center Headquarters in Pittsburgh. At another Westinghouse location near Pittsburgh, there is a headquarters industrial hygiene administrator whose engineering and laboratory facilities are available to all locations. The headquarters staff for the Nuclear Energy Systems (NES) includes a Director of Safety and Industrial Hygiene, who conducts special projects, drafts general policies, and provides coordination among the Industrial Hygiene supervisors at the various NES sites, a License Administrator for coordination of licensing activities, and a Manager of Nuclear Materials Management and Safeguards to provide guidance and advice on safeguarding special nuclear materials. Each site performing nuclear activities has at least one technically qualified, full time supervisor, with additional engineers and technicians as needed, in support of radiation protection, industrial hygiene, and safety services. Full time scientists and engineers with extensive experience in nuclear design lend support to the various facilities for nuclear criticality analysis where special nuclear materials are used. Computer service is available for determining safety parameters in nuclear criticality analyses.

April 18, 1972

Facilities in the Pittsburgh area include a wide variety of operations, ranging from research and development to full scale manufacturing, which require handling and processing many types of radioactive materials ranging in quantity from a few microcuries up to megacuries. Approximately 8,400 employes are engaged in nuclear activities at these facilities, which occupy about 2,850,000 square feet of floor space. Additional facilities at other geographical locations, involving approximately 3,900 people and 1,500,000 square feet of floor space, greatly expand the Corporation's capabilities in the nuclear energy field.

Very truly yours,



Karl R. Schendel
License Administrator

KRS:jh

Attachment: 1971 Annual Report
28 copies transmitted

CURRENT LIST OF LICENSES

| <u>Users and Site</u> | <u>License Numbers</u> |
|---|---|
| Nuclear Energy Systems Cheswick | SNM-338, 1120, 1170; 37-05809-01, 37-05809-02 SMB-355 |
| Columbia, S.C. | SNM-1107 |
| Forest Hills | 37-00497-09 |
| Waltz Mill | SNM-576, 770; 37-09442-04; TR-2 |
| Zion, Ill. | R-119, SNM-738 |
| Astronuclear Laboratories | |
| Cheswick | 37-05809-03 |
| Large | SNM-951; 37-09442-02; SMB-915 |
| Waltz Mill | 37-09442-01 |
| Research Laboratories | |
| Churchill | SNM-47; 37-00497-06; SMB-550 |
| Headquarters Industrial Hygiene Laboratory | |
| East Pittsburgh | 37-00497-13 |
| Semiconductor Division | |
| Youngwood | 37-07934-01 |

REGULATORY OPERATIONS



Westinghouse Electric Corporation

Power Systems

Electro Mechanical Division

Box 217
Cheswick Pennsylvania 15024
Cable WECHESWICK
(412) 274 6300
(412) 363 8700

February 11, 1974

U. S. Atomic Energy Commission
Directorate of Licensing
Washington, D. C. 20545

Attention: Mr. Leland C. Rouse, Chief
Fuel Fabrication and Reprocessing Branch



Gentlemen:

Subject: Termination of License SNM338 Docket 70-337

We have terminated operations previously authorized under License SNM-338 Docket 70-337. Amendment No. 35 was issued September 18, 1972, giving us guidelines for decontaminating the facilities and equipment. As required a copy of our report of our decontamination was sent to Region I, Directorate of Regulatory Operations August 31, 1973. An inspection of our facility was made by them October 31, November 1, 5-6, 1973. The inspection indicated we were in compliance with the guideline, with the exception of limits listed for fixed Beta-Gamma.

More specifically, the Beta-Gamma limits were exceeded in several drains which previously went to retention tanks. In addition the limits were also exceeded in the area of bolt holes where machinery was previously lagged and also at expansion joints. During the survey it was concluded accurate measurements of the dose rates could not be established due to improper calibration of our Beta-Gamma survey meters. The meters were calibrated using Cesium-137 rather than a Uranium standard.

We are presently modifying the facility for construction of stainless steel valves. During decontamination of the facility the drains were cleaned with an electric eel and flushed. The drains are not to be used in the future and since they are buried they will not present a health hazard to employees in the facility. It is our understanding Region I also agrees there is no existing health hazard. We have made sufficient analyses to be assured that the contamination is fixed. The only materials handled were low enriched Uranium Oxides with 5% U-235 (maximum). To further fix the contamination we will back-fill the drains under pressure with concrete.

ITEM # 243

C/242 10
0278

February 11, 1974

We will re-survey any existing lag bolt holes and where necessary sufficient concrete will be removed to reduce the radiation to acceptable levels. A correction factor obtained by calibration with depleted Uranium will be used on all readings to obtain values equivalent to Beta radiation doses from Uranium. Where it may be necessary, we will also remove concrete around the lips of drains where fixed contamination may be present.

Attached is a copy of our report of decontamination as originally presented to Region I. Included also are the results found by them during their survey. If these corrective actions are acceptable, we request that License SNM-338 be terminated and the facility be released for unconditional use.

Very truly yours,



Karl R. Schendel
License Administrator

rs

Attachment

NFD LUNCH AND LOCKER ROOMS

ATTACHMENT 1

[OUTSIDE BLDG.]

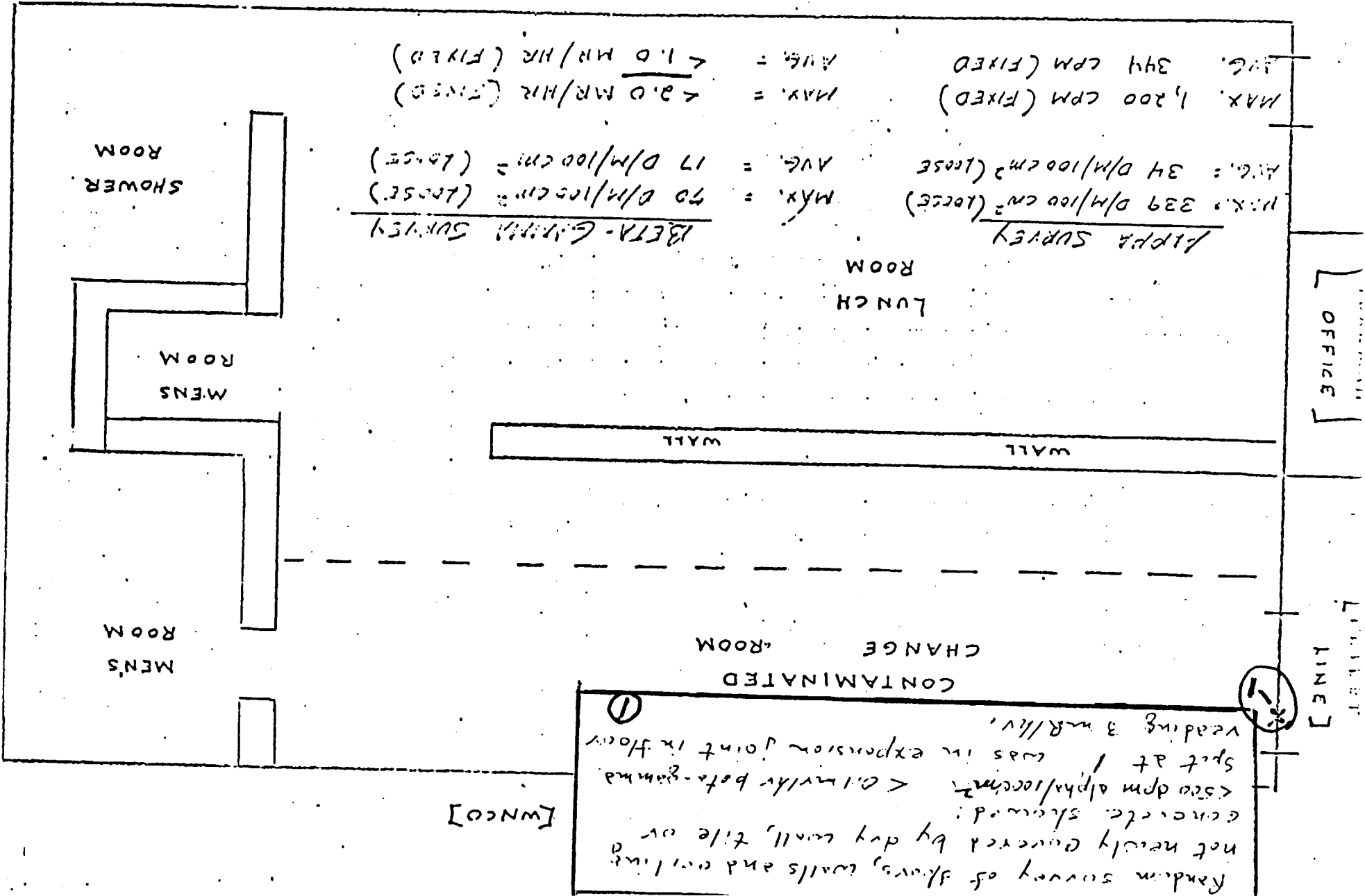

MAX. 1,200 CPM (FIXED)
AVG. 344 CPM (FIXED)

MAX. 339 D/M/100 CM² (LOOSE)
AVG. 34 D/M/100 CM² (LOOSE)

ALPHA SURVEY

MAX. = 2.0 MR/HR (FIXED)
AVG. = 1.0 MR/HR (FIXED)

MAX. = 70 D/M/100 CM² (LOOSE)
AVG. = 17 D/M/100 CM² (LOOSE)

BETA-GAMMA SURVEY

OFFICE

CHANGE ROOM

Random survey of floors, walls and ceiling
not newly covered by dry wall, tile or
concrete showed:
< 500 dpm alpha/beta < 0.1 mr/hr beta-gamma
split at 1' was in expansion joint in floor
reading 3 mr/hr.

①

[WNC0]

NFD

CHEMISTRY

LABORATORY

11/1/73

AEC SURVEY

Instrument Survey

Random Survey of Floor

< 1000 dpm/100cm²

< 0.1 mR/hr beta-gamma

Except at

14 (Floor) 11,000 dpm/100cm²

4 (Wall) 4,000 dpm/100cm²

The room was entirely covered with dry wall.

A section 4'x2' was removed at 14.

21 0.3 mR/hr beta-gamma

Wipes

| | dpm/100cm ² | dpm/100cm ² |
|---------|------------------------|------------------------|
| + Floor | 12 | 104 |
| + Wall | 202 | 446 |
| - Floor | 3 | 118 |
| - " | 6 | 170 |
| 7 " | 10 | 130 |
| 8 " | 10 | 92 |
| 9 " | 19 | 36 |
| 0 " | 10 | 160 |
| 1 " | 3 | 0 |
| 2 " | 3 | 108 |
| 3 " | 3 | 10 |

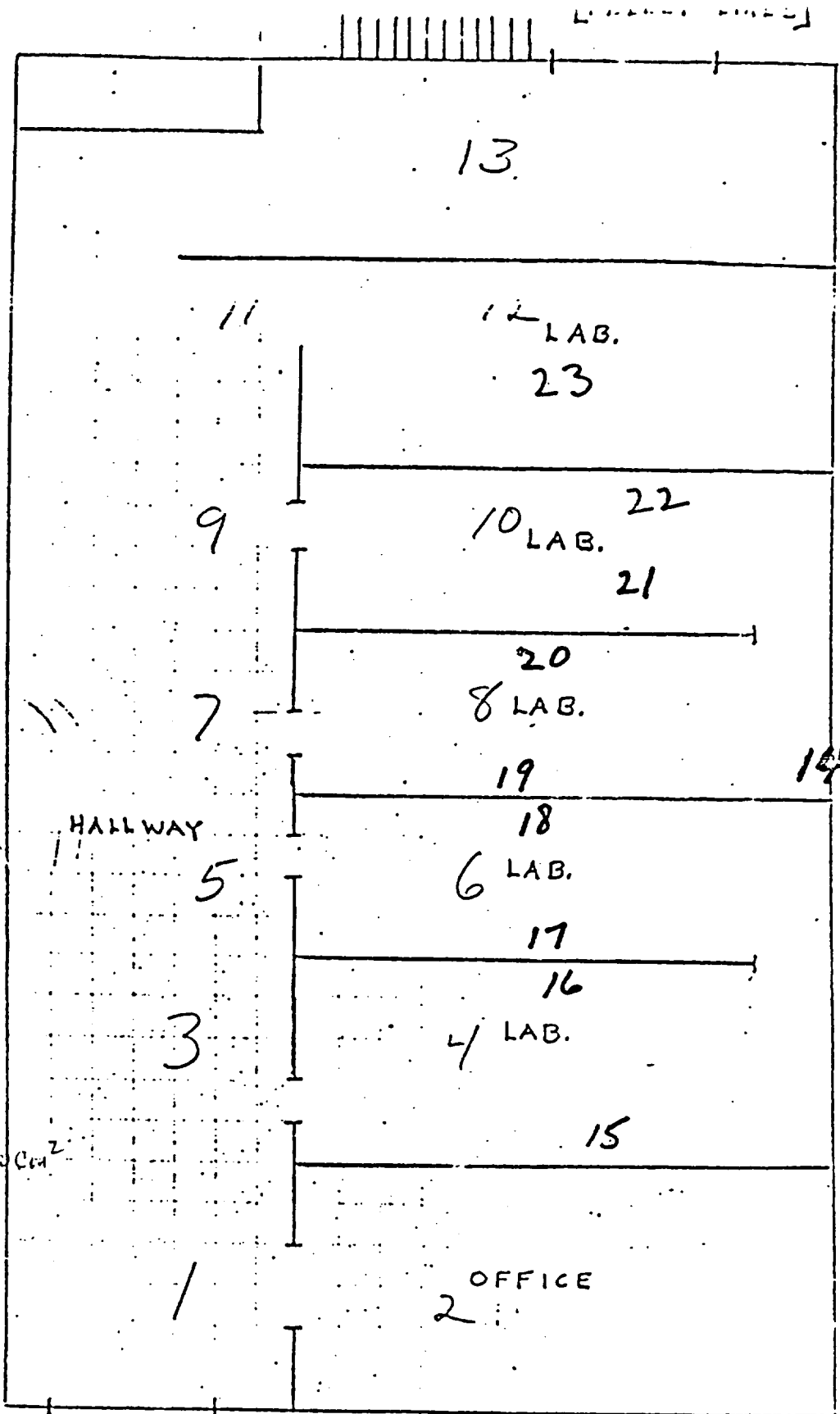

[STAIRS

TO

EMD]

ATTACHMENT 1

INSTRUMENT SURVEY

SMEAR

Locations 26 through 38 are floor drains or tie downs for previously installed equipment. Readings ranged from 0.2 to 5.0 mcr/hr. In addition rough spots in floor showed 0.2 to 2.0 mcr/hr. Walls showed < 0.1 mcr/hr. All alpha random readings were < 0.0001 mcr/hr.

Licensee dug out spots of contamination with jack hammer using wet mops to control dust. There was no contamination spread and wipes of the tools used showed no contamination. Not all spots were dug out. (3)

MACHINE SHOP

MACHINE SHOP

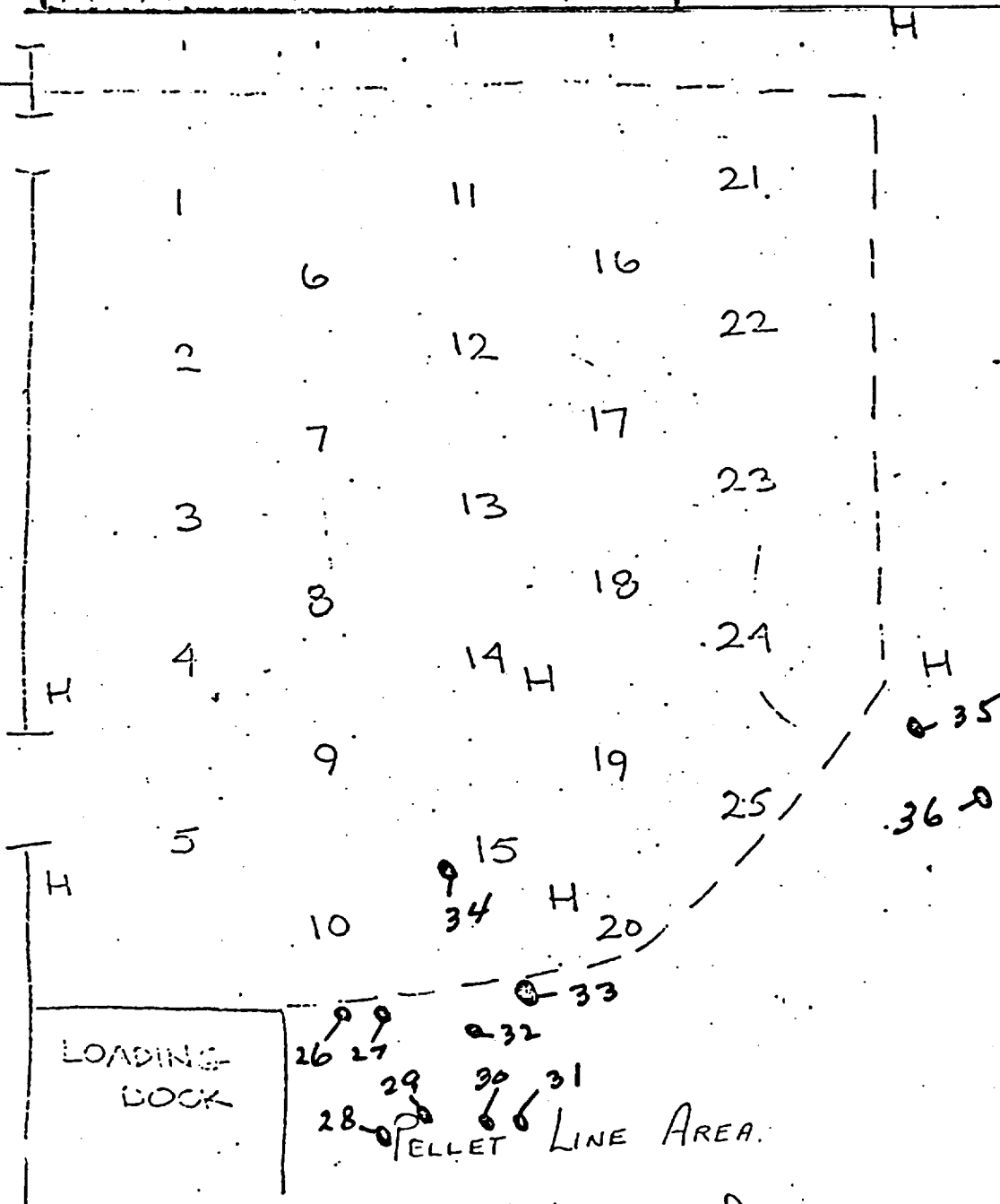

ORIENT ON LOADING DOCK.
(KRS.)

Vault Area. 937
938

[MAY SAY] AREA ↓

NFD ROD LOADING

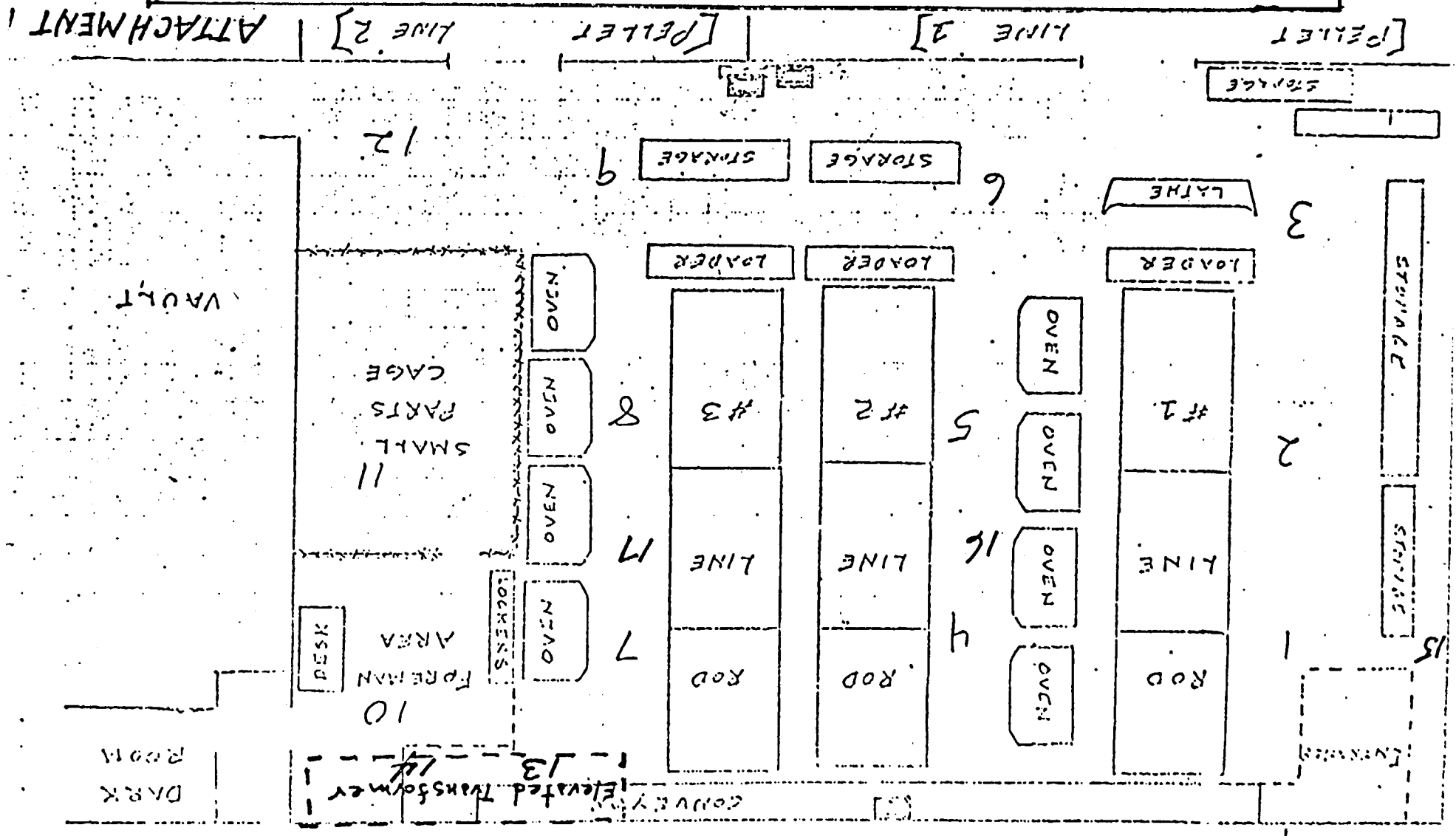

AEC SURVEY 11/6/73

INSTRUMENT SURVEY

Random Spot Checks
Floor, Walls & Transformers
< 500 dpm alpha/100cm²
< 0.1 mrv/hr beta-gamma

SMEARs

| | | | | | |
|----|----------------|---|---|---|---|
| 13 | Platform Floor | 3 | 0 | 0 | 0 |
| 14 | " " | 0 | 0 | 0 | 0 |
| 15 | Wall | 0 | 0 | 0 | 0 |
| 16 | Floor | 3 | 0 | 0 | 0 |

dpmx/100cm² dpmx/100cm²

(4)

NFB PIT

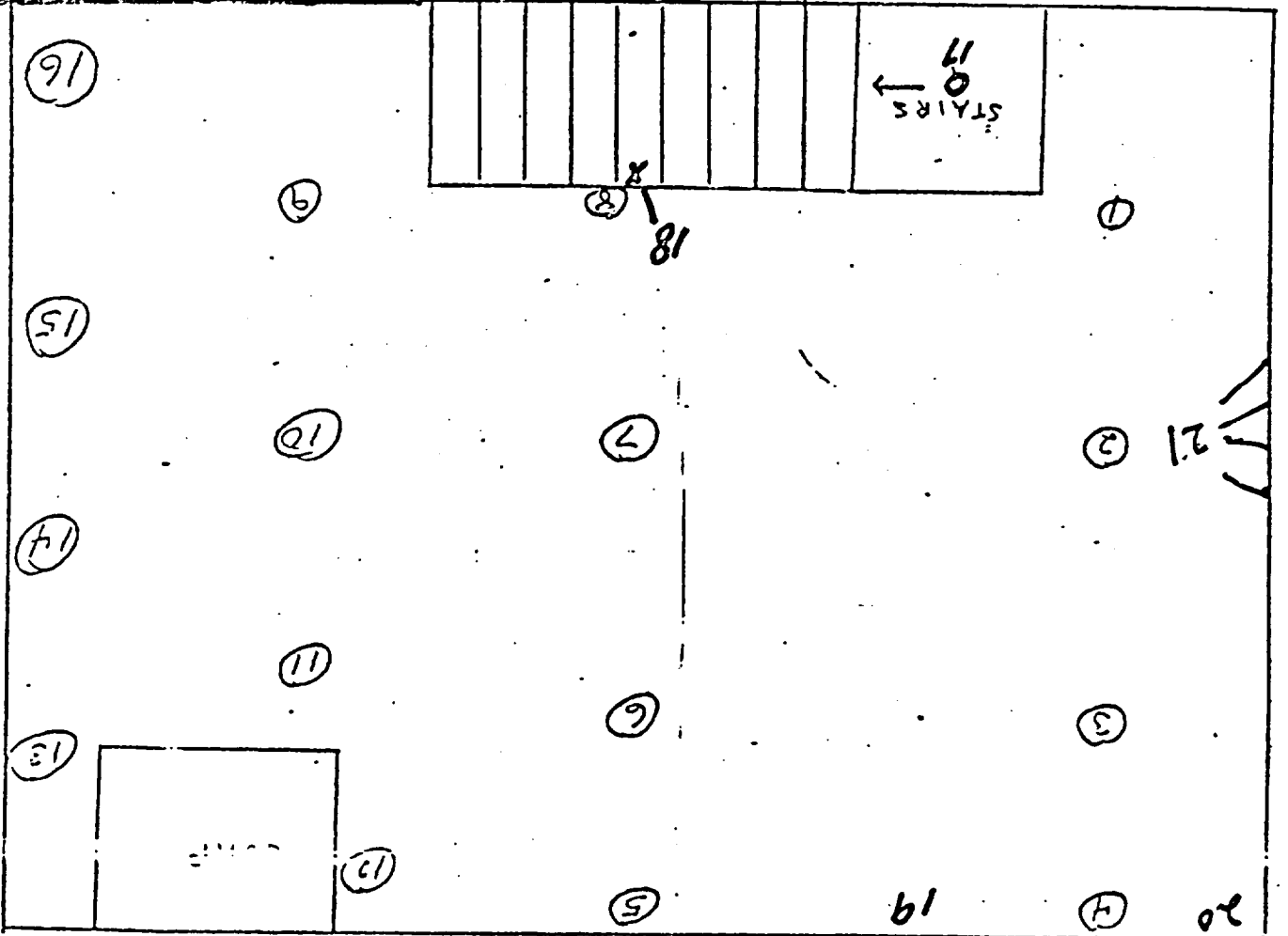

AEC SURVEY 11/173

Instrument Survey

- 17 Pipe Floor Level 3m/hrs
- 17 " " "
- 17 " " "
- 18 Floor Level 1 m/hrs
- 18 " " "
- 18 " " "
- 19 Floor " "
- 19 " " "
- 20 Wall " "
- 20 " " "
- 21 Wall (covered during 20 m/hrs)

- 17 Pipe Level 356 23/11
- 19 Floor 19
- 20 Wall 26

M/S

11/18/73

D/H 1100cm²

| | |
|-----|----|
| 11. | 36 |
| 12. | 12 |
| 13. | 6 |
| 14. | 3 |
| 15. | 9 |
| 16. | 12 |

| | |
|----|----|
| 1. | 39 |
| 2. | 6 |
| 3. | 18 |
| 4. | 18 |
| 5. | 6 |
| 6. | 3 |
| 7. | 6 |
| 8. | 6 |
| 9. | 16 |

[KOD LOADING AREA]

[OUTSIDE BLDG.]

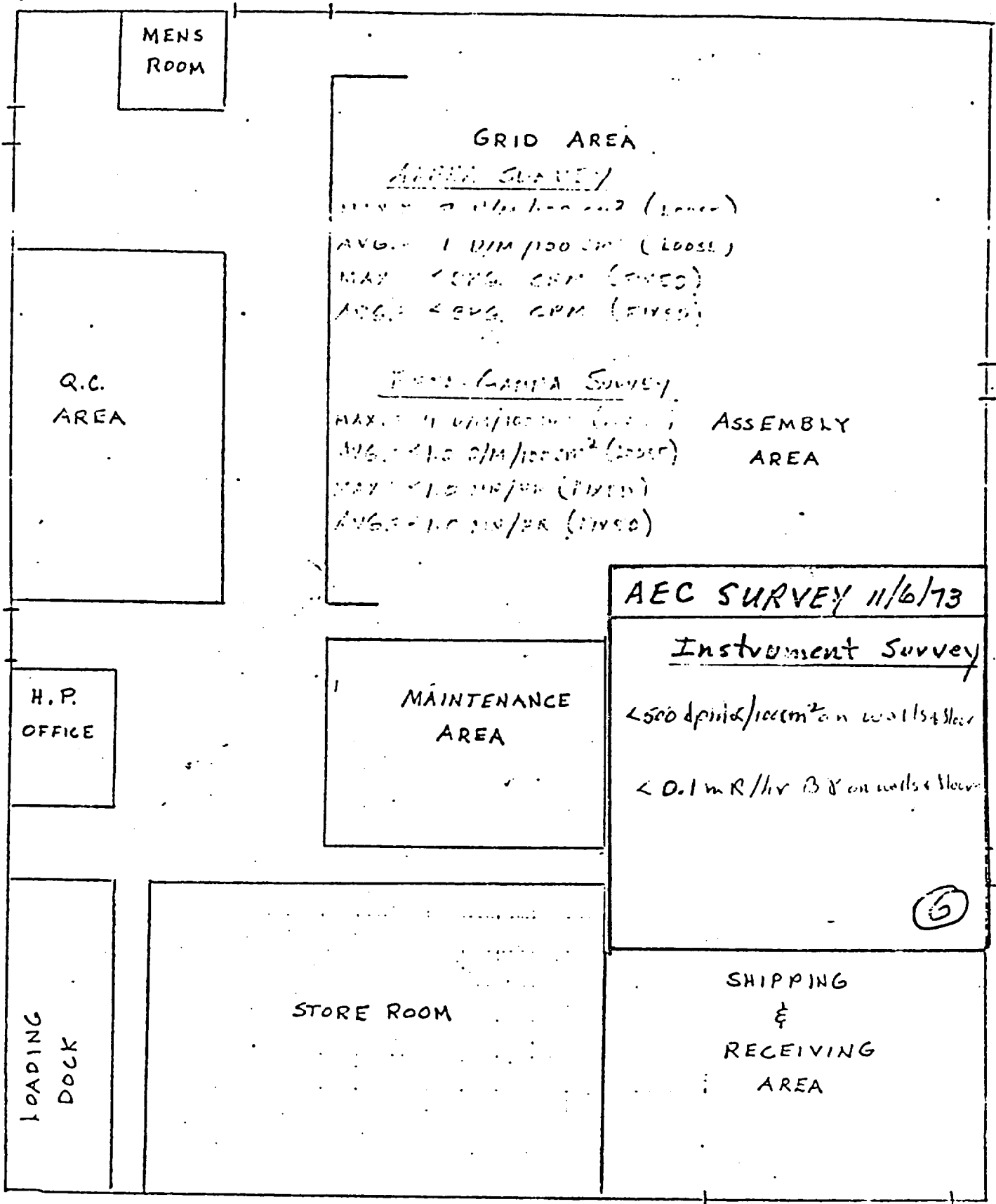

[OUTSIDE BLDG.]

NFD HIGH BAY AREA

ATTACHMENT 1

NFD HIGH BAY AREA

[OUTSIDE BLDG.]

⑦

ATTACHMENT 1

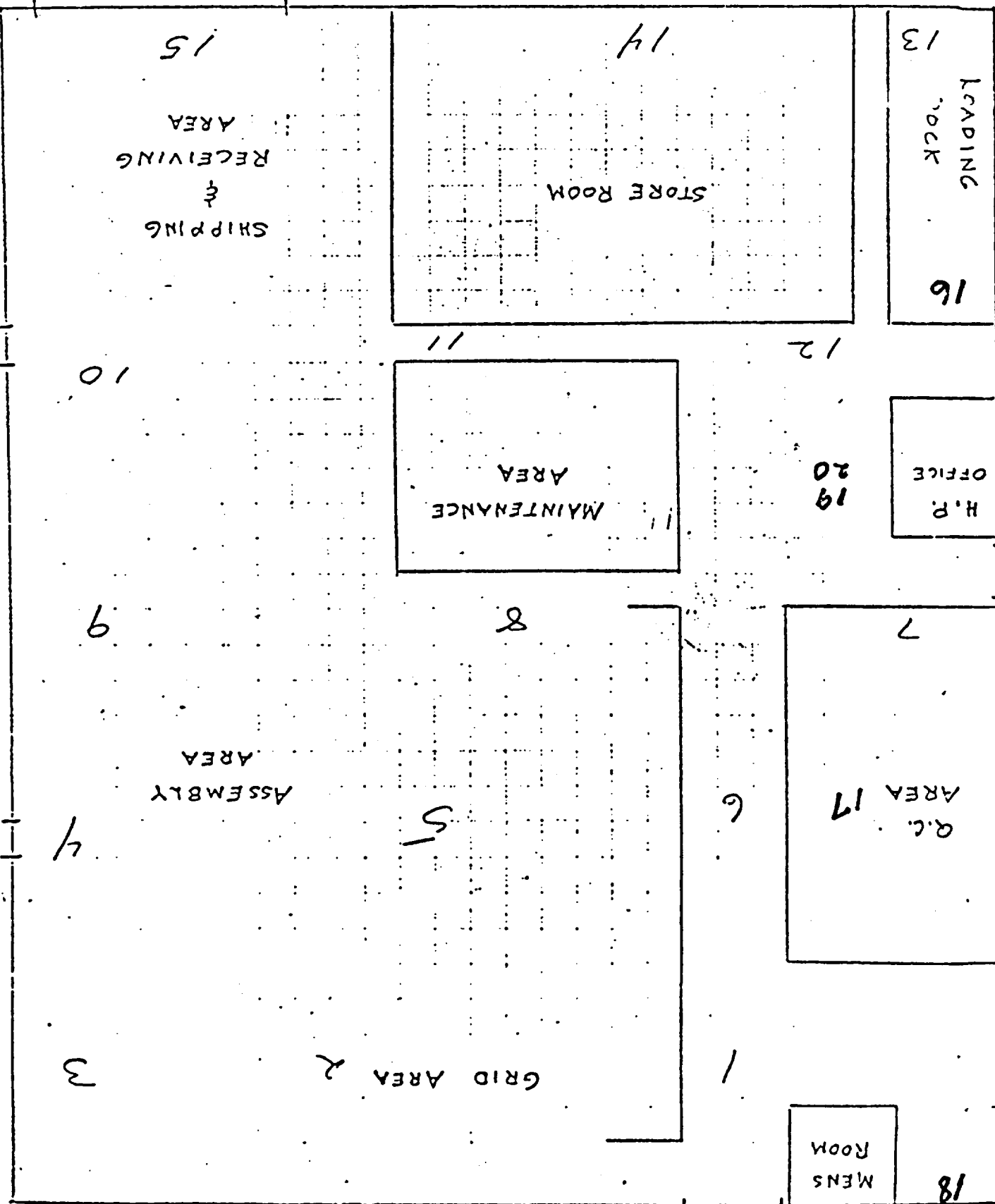

[OUTSIDE BLDG.]

[OUTSIDE BLDG.]

8/7/73

St. Louis

| | |
|-------------------------------|---|
| AEC SURVEY 11/6/73 | |
| <u>SMEARS</u> | |
| 16 Floor | 0 |
| 17 Floor | 0 |
| 18 Floor | 0 |
| 19 Remov'd Electrical Conduit | 0 |
| " | 3 |
| 20 " | 0 |
| ⑧ | |

$\frac{dpm \text{ of } \beta \text{ / section}}{dpm \text{ of } \beta \text{ / section}}$
 $\frac{1}{1}$

| | |
|------------------------------|---|
| 15 | 0 |
| 14 | 0 |
| 13 | 0 |
| 12 | 0 |
| 11 | 0 |
| 10 | 0 |
| 9 | 0 |
| 8 | 4 |
| 7 | 0 |
| 6 | 0 |
| 5 | 0 |
| 4 | 0 |
| 3 | 0 |
| 2 | 0 |
| 1 | 0 |
| ----- | |
| RESULTS OF BETA-GAMMA SURVEY | |
| N F D SMears | |

11/6/73
 St. Louis
 AEC SURVEY

November 20, 1973

Note to File

I called Bob Twombly, General Manager, Nuclear Equipment Divisions, Westinghouse Corporation (Anthony's boss) on November 16. I told him that I thought it was a disgrace for Westinghouse to go through this exercise and have us write them a blast (reference November 16 letter) I told him that he should look into it, that we should not get into this problem and that the resubmittal should not be similar. He agreed thoroughly with me - very friendly conversation.

The above action was necessary to insure that Twombly knows that this issue was not acceptable.

Dictated by JPO'R

cc: Nelson
Knapp

Jim

ITEM # 244

1249
①



70-337
Region I

Westinghouse Electric Corporation

Power Systems

Water Reactor Divisions

Box 355
Pittsburgh Pennsylvania 15230

May 13, 1974

U. S. Atomic Energy Commission
Office of Regulation
Directorate of Licensing
Washington, D. C. 20545

Attention: Mr. L. C. Rouse, Chief
Fuel Fabrication & Reprocessing Branch

Gentlemen:

Subject: Termination of License SNM-338, Docket 70-337

The Westinghouse Electric Corporation notifies you herewith of the completion of the "corrective actions" specified in your letter of March 12, 1974. The very low level residual contamination around drain openings, lag bolt holes, and expansion joints has been reduced below allowable levels even when surveyed using a recalibrated Beta-Gamma survey meter.

We request that License SNM-338 now be terminated, and that the building be released to unrestricted use.

If you have any questions, please write me at the above address or telephone me on (412) 373-4652.

Very truly yours,

Karl R. Schendel

Karl R. Schendel
License Administrator

KRS:jh



c/245

ITEM # 245



MAR 12 1974

L:FFRB:RTW
70 337

Westinghouse Electric Corporation
ATTN: Mr. R. Schendel
P. O. Box 355
Pittsburgh, Pennsylvania 15230

Gentlemen:

This refers to your letter dated February 11, 1974, requesting termination of Special Nuclear Material License No. SIM-338.

We will consider terminating this license when we have received notification from you that the corrective actions proposed for certain building drains and for the areas around lag bolt holes and expansion joints have been completed.

We are planning to complete our final action on this request in 60 days pending a satisfactory response from you within this period of time.

Distribution:

PDR

~~State Health Official~~

Docket File

Branch R/F

L:FM R/F

RO, HQ (2) ✓

HWerner

RGPage

AGabell

~~BBrooks~~

LCRouse

RJDube

RTWoolsey

RJDube

Sincerely,

Original Signed by
Leland C. Rouse

L. C. Rouse, Chief
Fuel Fabrication and Reprocessing
Branch
Directorate of Licensing

AUG 20 1974

L:FFRB:RTW
73-307
SM-333

Westinghouse Electric Corporation
ATTN: Mr. Karl R. Schendel
P. O. Box 355
Pittsburgh, Pennsylvania 15230

Distribution
PDR
Docket File
L:FM R/F
L:FFRB R/F
LCRouse
RJDube
RTWoolsey
State Health Official
ACabell
HWerner
BBrooks
RO:HQ (2) ✓

Gentlemen:

This is in response to your letter dated February 11, 1974 which requested termination of Special Nuclear Material License No. SM-333, and enclosed reports of final radiation surveys made by you and personnel from Region I, Directorate of Regulatory Operations.

Based on the data in these reports, and a final confirming contamination survey made by a Regulatory Operations inspector during the week of June 26-28, 1974, we have determined that due to the insignificance of the contamination which may be present no hazard to health and safety is involved as a result of AEC licensed activities, and therefore an AEC special nuclear material license would not be required of any person receiving or possessing the subject facility. Accordingly, as requested in your letter dated February 11, 1974, AEC Special Nuclear Material License No. SM-333 is hereby terminated.

FOR THE ATOMIC ENERGY COMMISSION

L. C. Rouse, Chief
Fuel Fabrication and Reprocessing
Branch
Directorate of Licensing

9/24/74

ITEM # 246

| | | | | | | |
|-----------|-----------------------------|-------------------------|--------------------------|--|--|--|
| OFFICE ▶ | L:FFRB <i>RT Woolsey</i> | L:FFRB <i>RJDube</i> | L:FFRB <i>LCRouse</i> | | | |
| SURNAME ▶ | RTWoolsey:mt | RJDube | LCRouse | | | |
| DATE ▶ | 7/12/74 | 7/17/74 | 8/17/74 | | | |

JUL 19 1974

P. J. Knapp, Senior, Facilities Radiological Protection Section

INSPECTOR EVALUATION

Westinghouse Electric Corporation
Cheswick, Pa.
License Nos. SMM-1120 and SMM-338 ✓

I observed no significant health and safety problems. It appears that the building and areas in which activities under License No. SMM-338 were conducted, can now be decommissioned.

Phillip C. Jerman
Radiation Specialist

CRESS
Jerman/mjd
7/17/74

Nilon
7/19/74

Crocker
Jwe
7/19/74

C/247
ITEM # 247

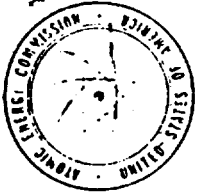

UNITED STATES
ATOMIC ENERGY COMMISSION
DIRECTORATE OF REGULATORY OPERATIONS
REGION 1
631 PARK AVENUE
KING OF PRUSSIA, PENNSYLVANIA 19406

JUL 19 1974

Westinghouse Electric Corporation
ATTN: Mr. Theodore Stern
Vice President and General
Manager
Water Reactors Division
P.O. Box 335
Pittsburgh, Pennsylvania 15230

License Nos. SNM-1120
SNM-338 ✓
Inspection Nos. 70-1143/74-03
70-337/74-01

Gentlemen:

This refers to the inspection conducted by Mr. Jerman of this office on June 26-28, 1974 at Cheswick, Pennsylvania of activities authorized by AEC License Nos. SNM-1120 and SNM-338 and to the discussions of our findings held by Mr. Jerman with Mr. Kunkle and other members of your staff at the conclusion of the inspection.

Areas examined during this inspection are described in the Regulatory Operations Inspection Report which is enclosed with this letter. Within these areas, the inspection consisted of selective examinations of procedures and representative records, interviews with personnel, measurements made by the inspector, and observations by the inspector.

In addition, our inspector examined those activities conducted under License No. SNM-338 relating to the subject covered in your letter to this office dated December 10, 1973. We have no further questions regarding this matter.

During this inspection, it was found that one of your activities appeared to be in violation of an AEC requirement. The item and reference to the pertinent requirement are listed in the enclosure to this letter. This letter constitutes a notice sent to you pursuant to the provisions of Section 2.201 of the AEC's "Rules of Practice", Part 2, Title 10, Code of Federal Regulations. Section 2.201 requires you to submit to this office within 20 days of your receipt of this notice, a written statement of explanation in reply, including: (1) corrective steps which have been or will be taken by you, and the results achieved; (2) corrective steps which will be taken to avoid further violations; and (3) the date when full compliance will be achieved.

C/247

ITEM # 248
③

In accordance with Section 2.790 of the AEC's "Rules of Practice", Part 2, Title 10, Code of Federal Regulations, a copy of this letter and the enclosed inspection report will be placed in the AEC's Public Document Room. If this report contains any information that you (or your contractor) believe to be proprietary, it is necessary that you make a written application within 20 days to this office to withhold such information from public disclosure. Any such application must include a full statement of the reasons on the basis of which it is claimed that the information is proprietary, and should be prepared so that proprietary information identified in the application is contained in a separate part of the document. If we do not hear from you in this regard within the specified period, the report will be placed in the Public Document Room.

Should you have any questions concerning this inspection, we will be pleased to discuss them with you.

Sincerely,

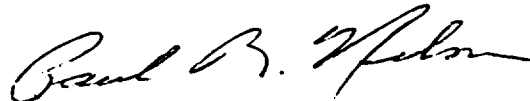

Paul R. Nelson, Chief
Radiological & Environmental
Protection Branch

Enclosures:

1. Description of Violation
2. RO Inspection Report Nos. 70-1143/74-03 and 70-337/74-01

cc: Mr. C. E. Anthony
General Manager
Electro Mechanical Division
Westinghouse Electric Corporation
Cheswick, Pennsylvania 15024

bcc (w/encls):
RO Chief, FS&EB (2)
RO:HQ (4)
L:D/D for Fuels and Mat's
PDR
NSIC
RO Files
DR Central Files
State of Pa,

ENCLOSURE

DESCRIPTION OF VIOLATION

Westinghouse Electric Corporation
Plutonium Fuels Development Laboratory and ARO Laboratories
Cheswick, Pennsylvania 15024
Docket No. 70-1143

One activity under your license appears to be in violation of AEC requirements. The apparent violation is considered to be of Category II severity.

Condition 14 of your license requires, in part, that the maximum interval for a bioassay be ninety days for individuals who work with plutonium or uranium.

Contrary to this requirement, the ninety day interval for a bioassay was not met for individuals who work with uranium.

OFFICIAL USE ONLY

Co. 3/6
WJH
6/23/10/6

FEB 28 1972

NMS:JVC
70-337
SNM-338

Westinghouse Electric Corporation
Monroeville Nuclear Center
Attn: Mr. Karl L. Schendel
License Administrator
Box 355
Pittsburgh, Pennsylvania 15230

DISTRIBUTION
PDR, w/o rpt
Docket 70-337, w/rpt
CKBeck, DR, w/rpt
LDLow, CO, w/o rpt
CO:I, w/rpt
SSmiley, DML, w/rpt
DLCrowson, NUMS, w/rpt
GC, w/o rpt
SO-I, w/o rpt
NMS Reading, w/o rpt
DR Reading, w/o rpt
NMS Case File, w/rpt
VJD Reading, w/o rpt

hsp

Gentlemen:

During the period October 15 through October 22, 1971, the District I Safeguards Office conducted an inspection of the safeguards control afforded the special nuclear material possessed by your company pursuant to AEC License No. SNM-338 in the following material balance areas:

- MBA-3 - Analytical Laboratory
- MBA-4 - Fuel Manufacturing
- MBA-5 - Development Laboratory

As a result of this inspection, it appears that certain of your activities were not conducted in full compliance with the requirements of 10 CFR 70.54 and the instructions for completing and distributing Form AEC-741 in that not all forms for shipments were completed and distributed within the time period specified (10 days).

This notice is sent to you pursuant to the provisions of § 2.201 of the AEC's "Rules of Practice," Part 2, Title 10, Code of Federal Regulations. You are required to submit to this office within twenty (20) days of this notice, a written statement or explanation in reply including: (1) corrective steps which have been taken by you, and the results achieved; (2) corrective steps which will be taken to avoid further violations; and (3) the date when full compliance will be achieved.

When separated from enclosures,
delete OFFICIAL USE ONLY markings

Sincerely,

ITEM # 249

Original signed by
C. D. W. Thornton

OFFICIAL USE ONLY

C. D. W. Thornton, Director
Division of Nuclear Materials

C1248

| | | | | | | | |
|-----------|---------|--------------------|---------|-------------|------------|--|--|
| OFFICE ▶ | NMS | NMS | NMS | NMS | Safeguards | | |
| SURNAME ▶ | JVC:kb | <i>[Signature]</i> | VJD | CDWThornton | | | |
| DATE ▶ | 2/18/72 | 2/18/72 | 2/17/72 | 2/15/72 | | | |

(6)

OFFICIAL USE ONLY

UNITED STATES
ATOMIC ENERGY COMMISSION
OFFICE OF
DIRECTOR OF REGULATION
DIVISION OF
NUCLEAR MATERIALS SAFEGUARDS

REPORT OF THE
INSPECTION OF
SAFEGUARDS CONTROL OF
NUCLEAR MATERIALS
OF

License No.: SNM-338 Docket No.: 70-337

WESTINGHOUSE ELECTRIC CORPORATION
CHESWICK, PENNSYLVANIA

Inspection No.: SO-I-54
Inspection Date: October 15 through 22, 1971
Report Date: January 10, 1972

For the Period: October 24, 1970
TO: October 13, 1971

DISTRICT I SAFEGUARDS
NEWARK, NEW JERSEY

OFFICIAL USE ONLY

OFFICIAL USE ONLY

Inspection of Safeguards Activities at
Westinghouse Electric Corporation
Cheswick, Pennsylvania
License No.: SNM-338 Docket No.: 70-337
SO-I-54

A. INTRODUCTION

An inspection of safeguards control over special nuclear materials at Westinghouse Electric Corporation was performed during the period October 15 through 22, 1971. The inspection covered the period October 24, 1970 through October 13, 1971. Under AEC License SNM-338, the licensee maintains three material balance areas as follows:

1. MBA-3--Analytical Laboratory

The MBA gives analytical support to fuel manufacturing and development laboratory. Incoming shipments of UO_2 powder, manufactured pellets and generated scrap are assayed for uranium content and impurities.

2. MBA-4--Fuel Manufacturing

Pellets are fabricated from low enriched UO_2 and inserted into tubes to form rods. The rods are then assembled into elements for use in power reactors. To date the facility does not have the capability to convert UF_6 to UO_2 or reclaim uranium from scrap. These services are obtained through contracts with other licensees or other Westinghouse divisions.

3. MBA-5--Development Laboratory

This area is now being utilized as a storage facility with the only operation being the conversion of scrap to U_3O_8 prior to shipment.

B. SCOPE OF INSPECTION

1. The inspection was made to determine the licensee's conformance to the safeguards requirements contained in Title 10, CFR, Part 70, "Special Nuclear Materials", Part 73, "Physical Protection of Special Nuclear Material" and the specific safeguards requirements contained in License SNM-338 Amendment SG-3.
2. The licensee's safeguards controls were reviewed in accordance with guidelines in the Handbook for Inspection of Class I Licensee, Operations Manual Appendix 1005A.

OFFICIAL USE ONLY

C. CATEGORIZATION

Each material balance area was categorized and sampled as follows:

MBA-3 & 4

| <u>Category</u> | <u>Description</u> | <u>No. of Line Items</u> | <u>Kgs. U-235</u> | <u>No. of Samples</u> |
|-----------------|----------------------------|------------------------------|-------------------|---------------------------|
| I | UO ₂ press feed | 240 | 223 | 346 |
| I | Sintered pellets | 62 | 512 | 49 |
| III | Sludges, scrap pellets | 618 | 191 | 630 |
| V | Fuel rods | 125 | 178 | 143 |
| V | Fuel assemblies | 141 | 1,654 | - |
| | Items not sampled | 98 | <u>33</u> | <u>-</u> |
| | | | 2,791 | 1,168 |

At a preinspection meeting, four containers of UO₂ were sampled for analysis by NBL and held as standards for the gamma counting of UO₂, press feed, sludges, and scrap pellets. This material is packaged in fiber packs each having a net weight of about 18 kgs with a few exceptions which only have about 1 kg. A 100% gross weight check and gamma count was performed on each of these items. With the exception of one 10 kg weight error which was corrected on the inventory listing by the licensee, all items met the AEC inspection team's accept criteria.

Forty nine line items of pellets were verified by checking the number of pellets per tray and the number of trays per line item. One pellet was taken from each line item, weighed and gamma counted against the SD-I standard pellets.

Two fuel rods were fabricated in the presence of the inspection team. Four pellets were taken from the trays used in filling each rod and were sent to NBL for analysis. Fuel rods were taken from two active jobs and gamma counted against the two standards. The gross weight check and gamma count data for the fuel rods was acceptable.

All fuel assemblies were verified by serial number or supporting data when the serial number could not be observed.

MBA-5

| <u>Category</u> | <u>Description</u> | <u>No. of Line Items</u> | <u>Grams Pu</u> | <u>Kgs U-235</u> |
|-----------------|---|------------------------------|-----------------|------------------|
| III | UO ₂ , U ₃ O ₈ sludges | 8 | - | 2 |
| V | Fuel rods | 10 | - | 4 |
| V | Fuel rods | 1 | <u>1,228</u> | <u>-</u> |
| | | | 1,228 | 6 |
| | Total all MBAs | | <u>1,228</u> | <u>2,797</u> |

OFFICIAL USE ONLY

The only verification at this MBA was the observation of inventory items.

D. SUMMARY OF FINDINGS

1. The licensee is not in full compliance with 10 CFR 70.54 and the physical inventory summary by projects was not consistent with the way the ledgers were being maintained.

2. Summary of MUF Components and Associated Limits of Error

| | MBA-3, 4 Kg U-235 | LE Kg U-235 | MBA-5 Gm U-235 | LE Gm U-235 | MBA-5 Gm Pu |
|------------|----------------------|----------------|-------------------|----------------|----------------|
| E.I. | 3,359.9 | 24.6 | 28,789 | 3,157 | 1,228 |
| Receipts: | 7,067.2 | 32.8 | 8,971 | 0 | 0 |
| Shipments: | 7,635.2 | 24.9 | 32,209 | 0 | 0 |
| M/Ds: | 1.6 | 0.05 | 52 | 0 | 0 |
| E.I. | 2,790.8 | 12.4 | 5,387 | 0 | 1,228 |
| MUF | (.5) | 49.5 | 112 | 3,157 | 0 |

3. Measured Discards and MUF as a Function of Thruput (thruput is BI + R)

| MBA-3, 4-- | | Kg U-235 | % of Thruput |
|------------|---------|----------|--------------|
| | Thruput | 10,427.1 | --- |
| | M/D | (.5) | (0.005) |
| | MUF | 1.6 | 0.015 |
| MBA-5: -- | Thruput | 37.8 | --- |
| | M/D | .05 | 0.13 |
| | MUF | .11 | 0.29 |

E. DISCUSSION OF FINDINGS

1. 10 CFR, Part 70, Section 70.54, Nuclear Materials Transfer Reports, states that the AEC-741 is to be forwarded to the Commission and the shipper of the material within 10 days after the material is received. A review of Transfer Series ZQN-ZYP indicated that 37 AEC-741s were dispatched after the 10 day period.

2. The presentation of the Physical Inventory summary by projects was not consistent with the way the ledgers were being maintained. In some instances, leased and privately owned jobs had not been segregated. They had been grouped together and losses allocated to privately owned and leased jobs equally, or only to privately owned jobs.

F. RESULTS OF THE RECORDS AUDIT

1. The review of Westinghouse, NFD (MBA 4 & 5) records, ledgers, reports and supporting documents revealed no inconsistencies. Material Status Reports had been submitted for the review period and had been properly supported by the licensee's records and ledgers.

OFFICIAL USE ONLY

2. MBA 4 & 5 and Central Accountability Records were reconciled monthly.
 3. The AEC-741 review indicated laxity in dispatching the receiver's copy of the AEC-741
 4. The licensee's inventory position as reported was substantiated by the MBA records.
 5. Acceptable accounting practices and procedures were employed by the licensee.
- G. 10 CFR, PART 73
- No exceptions were noted.

January 10, 1972
Date of Report

APPROVED: 

Patrick J. De Lorenzo



Walter G. Martin
Director
District I Safeguards Office

OFFICIAL USE ONLY

**UNITED STATES ATOMIC ENERGY COMMISSION
OFFICE OF
DIRECTOR OF REGULATION
DIVISION OF
NUCLEAR MATERIALS SAFEGUARDS**

**report of the
INSPECTION OF SAFEGUARDS
CONTROL OF NUCLEAR MATERIAL
of**

License No.: SNM-338

Docket No.: 70-337

**WESTINGHOUSE ELECTRIC CORPORATION
(Section II)**

Inspection No.: SO-I-18

Inspection Date: 10/29/69 - 11/7/69

Report Date: March 12, 1970

For the Period: 11/1/68

To: 10/31/69

Inspection of Safeguards Activities
 Westinghouse Electric Corporation
 Nuclear Fuel Division
 Cheswick, Pennsylvania
 License No. SNM-338 Docket No. 70-337
 SO-I-18

Section II

A. SUMMARY AND CONCLUSIONS

1. The total quantity of U-235 and plutonium presented by the licensee as determined by the taking of a physical inventory on October 29, 1969 has been accepted by the inspection team. A summary of the inspection teams verification which was performed by placing similar types of material into reproducible categories having similar accept-reject criteria appears as Exhibit I of this report. Attribute certification statements for the categories have been included. Less than acceptable certification statements were noted for plutonium and enriched uranium compounds at MBA-6, the plutonium research and development facility. These poor statements were due to the failure of the licensee to measure the special nuclear material content of all inventory items. A less than acceptable attribute statement also appears for sludges and scrap pellets. This poor statement is attributed to the use of nominal factors and failure on part of the licensee to measure each container. The licensee has been given copies of assays completed by the New Brunswick Laboratory. No comments have been received from the licensee.
2. No additional items of non-compliance are noted since the submission of Part I of this report.
3. The licensee may be cited for failure to measure all quantities that have been identified as wastes such as scrap compounds and sludges in lieu of the use of nominal values.

B. SAMPLING PROCEDURES

1. There were no deviations from Nuclear Material Safeguards sampling procedures.
2. The number of samples withdrawn for analyses appear in the inventory verification sample summary report.

The material unaccounted for (MUF) and associated limits of error as reported by the licensee are as follows:

| MBA | MUF-U-235 | LE (Limit of Error) |
|-----|-----------|---------------------|
| 4 | 20,904 g | 89,476 g |
| 5 | 171 g | 276 g |
| 6 | 138 g Pu | 132 g |
| 6 | 94 g | 171 g |

OFFICIAL USE ONLY

The limits of error associated with material unaccounted for was calculated by the licensee by assigning estimated limits of errors to receipts, shipments, ending inventory, beginning inventory, and measured discards at each isolated material balance area and statistically combining these limits by extracting the square root of the sums of the square of the above components. The inspection team does not agree with the 20,904 g MUF assigned to MBA-4 for the period under review. An independent calculation by the inspection team of 23,067 g U-235 appears in Part I of this report. On 2/25/70, the licensee was requested to review the reported MUF. We will keep you informed of any changes.

C. RESULTS OF THE AUDIT

1. A review of MBA records, ledgers and supporting documents indicated (a) improper identification of measured discards and MUF, (b) ending inventory balances of the MBA ledger did not agree with Central Accountability Records, and (c) completed assemblies as an item of inventory were excluded from periodic physical inventories. Item (a) has been cited as a program weakness. Items b & c were discussed with management and they indicated prompt corrective action would be taken.
2. Although the licensee had some program weaknesses, their inventory position as reported was substantiated by the Central Accountability Ledgers in accordance with acceptable accounting procedures.

DATE OF REPORT: March 12, 1970

APPROVED: _____

Walter G. Martin
Walter G. Martin, Director
District I Safeguards Office

EXHIBIT I

SUMMARY OF INVENTORY VERIFICATIONS

| Type of Material | No. of Items in Category | MBA No. | No. of Check Weighings | | Net Wt. Certification(1) | Licensee AEC Net Wt. | | No. of U-235 or Pu | | U-235 or Pu Certification(1) | Licensee AEC Gms. | | Sample Bias | Limit of Error |
|---|--------------------------|---------|------------------------|----------|--------------------------|----------------------|--------|--------------------|----------|------------------------------|-------------------------------|-------------------------------|-------------|----------------|
| | | | Rejects | Rejects | | Gms. | Gms. | Comp. | Rejects | | Gms. Pu or U-235 Sample Items | Gms. Pu or U-235 Sample Items | | |
| Pu Compounds(2) | 103 | 6 | 29 | 3 | 77 | 5508 | 5510 | 29 | 7 | 62 | 667 | 635 | 32 | 32 |
| EU Compounds(2) | 92 | 6 | — | — | — | — | — | 23 | 18 | 10 | 1167 | 1070 | 97 | 43 |
| Pu, EU Fuel Rods | 87 | 6 | Note (3) | — | — | — | — | — | — | — | 646 Pu 1555 U-235 | — | — | — |
| UO ₂ , U ₃ O ₈ UC Powder | 35 | 5 | 27 | 0 | 92 | 78030 | 78049 | 27 | 1 | 90 | 4863 | 4779 | 84 | 42 Note (4) |
| UO ₂ Pellets | 106 | 5 | 30 | 2 | 82 | 102516 | 102547 | 30 | 1 | 86 | 5212 | 5220 | -8 | 34 |
| UO ₂ Fuel Rods | 204 | 5 | 30 | 0 | 90 | 15017 | 15013 | — | — | — | — | — | — | — |
| Powder, Pellet Scrap | 44 | 5 | 24 | — | — | 56891 | 56903 | — | — | — | — | — | — | — |
| UO ₂ Press Feed, Powder | 287 | 4 | 32 | 3 | 78 | 552675 | 552680 | 32 | 2 | 82 | 13519 | 13489 | 30 | 51 |
| Sintered Pellets | 106 | 4 | 4 | 0 | 81 | 42 | 41 | 40 | 0 | 94 | 9599 | 9682 | 83 | 79 |
| Sludges, Scrap Pellets | 326 | 4 | 32 | 5 | 70 | 349340 | 350830 | 32 | 5 | 70 | 8802 | 8576 | -226 | 483 |
| Fuel Rods | 109 | 4 | 32 | Note (5) | — | — | 96640 | 32 | Note (6) | — | — | — | — | — |

(1) Attribute certification statement based on hypergeometric distribution:

An appraisal of the sample results concluded that with at least 95% confidence, at least _____% of the items of _____ material type meet AEC acceptance criteria.

(2) In MBA 6, there were 103 samplable items of which 92 contained enriched uranium. 29 items were check weighed and sampled. 23 of the 29 contained enriched uranium and plutonium.

(3) The fuel rods were in process. The Pu and EU content of 32 rods was checked by tracing the production records and transfer documents.

(4) The bias reflects NBL's consistent low U and U-235 assay values as compared to licensee's values.

(5) The AEC gross check weighed the fuel rods: since no tare or non-fuel component weights were available, no AEC net weight was determined, however, licensee net weight appeared reasonable.

(6) Qualitative U-235 performed by Gamma Spectrometry, each rod counted was compared to a standard rod made in the presence of the AEC. The count rate of each rod compared to the standard rod indicated that the licensee's values were reasonable.

Accept Reject Criteria

Net weight \pm 3 gms.

Pu content of Pu compounds \pm 16.40 % relative, based on duplicate samples.

U-235 content of EU compounds \pm 2.28 % relative, based on duplicate samples.

NMS:FJM
70-337

APR 28 1971

Craker
~~WMB~~
~~SP4~~

H/O

Westinghouse Electric Corporation
Attn: Karl R. Schendel
Monroeville Nuclear Center
P. O. Box 355
Pittsburgh, Pennsylvania 15230

Gentlemen:

During the period of October 23 through October 30, 1970, the District I Safeguards Office made a safeguards inspection of the special nuclear material possessed by your company pursuant to AEC License No. SNM-338.

As a result of this inspection, it appears that certain of your activities were not conducted in full compliance with the license conditions contained in the safeguards amendment to SNM-338 in that:

1. your procedures manual for operations in your MBA-4 did not reflect your current nuclear material control procedures for implementing the safeguards requirements of 10 CFR 70 and section 3.0 of your safeguards amendment as required by Condition 1.2;
2. the limits of error associated with the quantity of special nuclear material in your measured discards from your MBA-5 were not determined as required by Condition 3.1; and
3. contrary to Condition 3.4, in the opinion of the inspection team, you did not correctly propagate the errors associated with your material balance in computing the limits of error for material unaccounted for.

On October 30, 1970, Mr. Ira Cohen, District I Safeguards Office, discussed the inspection team's findings with members of your staff.

c/250
ITEM # 251
(7)

Westinghouse Electric Corporation

-2-

APR 26 1971

This notice is sent to you pursuant to the provisions of Section 2.201 of the AEC's "Rules of Practice," Part 2, Title 10, Code of Federal Regulations. Section 2.201 requires you to submit to this office within twenty (20) days of your receipt of this notice, a written statement or explanation in reply including: (1) corrective steps which have been taken by you, and the results achieved; (2) corrective steps which will be taken to avoid further violations; and (3) the date when full compliance will be achieved.

Sincerely,

(Signed) C. D. W. Thornton

C. D. W. Thornton, Director
Division of Nuclear Materials
Safeguards

Distribution

- PDR
- Docket 70-337, w/rpt
- CKBeck, DR, w/o rpt
- LDLow, CO, w/o rpt
- CO:I, w/rpt
- LJohnson, DML, w/rpt
- DLCrowson, SMM, w/rpt
- GC, w/o rpt
- HJMcAlduff, OR, w/rpt
- SO-I, w/o rpt
- NMS Reading, w/o rpt
- DR Reading, w/o rpt
- NMS Case File, w/rpt
- VJD Reading, w/o rpt

| | | | | | | |
|-----------|--------------------|-----------|-------------|--|--|--|
| OFFICE ▶ | NMS | NMS | NMS | | | |
| SURNAME ▶ | FJN [Signature] kb | VJD Amico | CDWThornton | | | |
| DATE ▶ | 4/25/71 | 4/25/71 | 4/25/71 | | | |

OFFICIAL USE ONLY

UNITED STATES
ATOMIC ENERGY COMMISSION
OFFICE OF
DIRECTOR OF REGULATION
DIVISION OF
NUCLEAR MATERIALS SAFEGUARDS

report of the
INSPECTION OF
SAFEGUARDS CONTROL OF
NUCLEAR MATERIALS
OF

RIS:

License No.: SNM-338

Docket No.: 70-337

WESTINGHOUSE ELECTRIC CORPORATION
CHESWICK SITE

Inspection No.: SO-I-35

Inspection Date: 10/23-30/70

Report Date: 2/25/71

For The Period: 11/1/69

To: 11/23/70

DISTRICT I SAFEGUARDS OFFICE
NEWARK, NEW JERSEY

OFFICIAL USE ONLY

OFFICIAL USE ONLY

Inspection of Safeguards Activities
Westinghouse Electric Corp, Cheswick Site
Fuel Manufacturing Department and Material System Laboratory
Level II Inspection
Final Report
SNM-338 Docket No. 70-337

A. INTRODUCTION

A Level II inspection of safeguards control over special nuclear material at Westinghouse Electric Corporation was performed during the period October 23 through October 30, 1970. The inspection covered the period November 1, 1969 through November 23, 1970. The licensee maintains three material balance areas under SNM-338 as follows:

MBA-3 Analytical Laboratory

The laboratory gives analytical support to fuel manufacturing and the Engineering Development Laboratory. Incoming shipments of UO_2 powder, manufactured pellets, and generated scrap are assayed for uranium, Uranium-235, and impurities.

MBA-4 Fuel Manufacturing

Pellets are fabricated from low enriched uranium oxide converted from uranium hexafluoride at the Westinghouse Columbia, S.C. plant. The pellets are inserted into tubing to form rods which are then assembled into elements for use in power reactors. Generated scrap is shipped off site to other licensees for reclamation; eventually this material will be shipped to the Columbia plant for reclamation.

MBA-5 Material Systems

This area develops and tests new techniques of fuel fabrication for possible use by fuel manufacturing. The capabilities at the development laboratory are similar to those at fuel manufacturing.

B. SCOPE OF INSPECTION

1. The inspection was made to determine the licensee's conformance to the safeguards requirements contained in Title 10, CFR, Part 70, "Special Nuclear Material," Part 73, "Physical Protection of Special Nuclear Material," and the specific safeguards requirements contained in License No. SNM-338 SG-2. Physical Protection practices of material in storage were not reviewed by the District I inspection team.

2. The licensee's safeguards controls were reviewed in accordance with the guidelines in the Handbook for inspection of Class I licensee's Operations Manual Appendix 1005A. Since this was a level 2 inspection, the inventory was not tested by categorization and sampling. A level II inspection requires as a substitute the evaluation of process points by sampling. This was not done at MBA-5 because of the diverse nature of the operations. However, this evaluation was performed at MBA-4.

C. SUMMARY OF FINDINGS

1. MBA-4

- a. There was no items of non-compliance noted.
- b. A program weakness was noted in implementation of license condition 1.2.
- c. Measured discards & MUF (all values kilograms U-235 unless otherwise noted) for inspection period.

| | |
|--------------------------------------|-------------------------|
| Beginning Inventory & Receipts(BI+R) | 12,649.4 ⁽¹⁾ |
| Measured Discards(MD) | 1.5 |
| MUF | 27.3 |
| MD/Bi+Rx100 | 0.0% |
| MUF/Bi+Rx100 | 0.2% |

(1) U-235 in approx. 3% enriched uranium

- d. There were no significant shipper-receiver differences for the inspection period.

2. MBA-5

- a. There were no items of non-compliance noted.
- b. Program Weaknesses have been noted in regard to implementation of license conditions 3.1 & 3.4.
- c. Measured discards & MUF for the inspection period. (all values in grams U-235 unless otherwise indicated).

| | |
|--------------------------------|--------|
| Beginning Inventory & Receipts | 53,038 |
| Measured Discards | 236 |
| MUF | 71 |
| MD/Bi+Rx100 | 0.44% |
| MUF/Bi+Rx100 | 0.31% |

- d. There were no significant shipper-receiver differences for the inspection period.

OFFICIAL USE ONLY

D. EVALUATION OF PROCESS POINTS - MBA-4

The review of process points was performed by withdrawing samples of virgin uranium oxide, Uranium oxide pellets and calcined grinder wheel sludge. Samples were forwarded to the New Brunswick Laboratory for uranium and uranium-235 assay. Seven samples were withdrawn for this evaluation. A slight significant bias of .14% relative for U +.3% relative for U-235 was noted, NBL was lower for uranium and higher for U-235.

E. MATERIAL UNACCOUNTED FOR AND ASSOCIATED LIMITS OF ERROR

The U-235 MUF and associated limits of error were:

| | |
|-------------------|---------------|
| MBA-4 (kilograms) | MBA-5 (grams) |
| 27+65 | 71+3,169 |

The limits of error of the MUF were determined by the licensee by determining limits of error for beginning inventory, receipts, shipments, measured discards and ending inventory for the inspection period and combining these by the square root of the sum of the squares.

| | MBA-4 (kilograms U-235) | L.E. (kilograms U-235) | MBA-5 (grams) | L.E. (grams) |
|-------------------|----------------------------|---------------------------|------------------|-----------------|
| Beginning Inv. | 3,798.4 | 33.1 | 31,598 | 181 |
| Receipts | 8,851.0 | 35.3 | 21,440 | 41 |
| Shipments | (9,260.8) | 36.4 | 23,942 | 210 |
| Measured Discards | (1.5) | .2 | 236 | 0 |
| Ending Inventory | (3,359.9) | 24.6 | 28,789 | 3,157 |
| MUF | 27.1 | 65.3 | 71 | 3,169 |

F. RESULTS OF THE RECORD AND REPORTS AUDIT

- The review of records, ledgers, reports and supporting documents revealed no inconsistencies. Material status and balance reports had been submitted for the period required and had been properly supported by the Licensee's records and ledger.

2. The Licensee's inventory position as reported was substantiated by the material balance area ledgers in accordance with acceptable accounting procedures.

G. DISCUSSION OF PROGRAM WEAKNESSES

MBA-4

A program weakness in regard to license condition 1.2 is noted because of the following:

- a. The implementation of the safeguards requirements of 10 CFR Part 70 is not discussed in the manual.
- b. The full implementation of license condition 3.1 (the licensee complies with the condition) does not appear in the manual since:
 1. there is no procedure for the determination of sampling error for items.
 2. there is no procedure for the determination of component limit of error necessary for L.E.(MUF) propagation.
 3. procedures do not explicitly establish sampling rates at measurement points.
 4. references to statistical terminology aren't explicit. It is not clear whether uncertainty refers to limits of error or one sigma precision errors.

MBA-5

A program weakness is noted in regard to condition 3.1 because of the failure to determine the limits of error of measured discards. A program weakness is noted in regard to condition 3.4 because of the statistically invalid method of determining the limit of error associated with the physical inventory and subsequent invalid presentation of the LE of the U-235 MUF. The licensee estimated a sampling error of 25% relative to the uranium weight; the uranium L.E. per item was used as the U-235 L.E. yielding limits of error of approximately 300% relative. A more reasonable L.E. would have been estimated if the 25% relative error was applied to the U-235 value per item. The licensee also failed to propagate errors of groups of items and overstated the limit of error of the physical inventory by applying the 25% factor to groupings of items.

DATE OF REPORT February 25, 1971

APPROVED: 

Ira Cohen



Walter G. Martin, Director
District I Safeguards Office

Crocket
WRL

DISTRIBUTION:
Public Document Room
Docket File 70-337, w/rpt
CKBeck, DR
JAMcBride, DML, w/rpt
LDLow, CO
CO:I, w/rpt
SO-I
OGC (2)
DLCrowson, OSMM, w/rpt
NMS Case File, w/rpt
DR Rdg File
NMS Rdg File
VJD Rdg File
HMcAlduff, OR, w/rpt

70-337

FEB 17 1969

Westinghouse Electric Corporation
Atomic Power Divisions
P. O. Box 255
Pittsburgh, Pennsylvania 15230

Attention: Mr. A. J. Povejsil
Nuclear Fuel Division
General Manager

Gentlemen:

During the period November 6-15, 1968, our District I Safeguards Office conducted a safeguards inspection of the special nuclear material possessed pursuant to AEC License No. SRM-355 at your Cheswick, Pennsylvania, facility. As a result of the inspection, the inspection team discussed with you certain improvements needed in your material control and accountability program as follows:

- (1) Values for material unaccounted for should be based on results of a physical inventory.
- (2) The laboratories should periodically check standards and evaluate the precision of measurements used in the laboratory for analyses of impurities, uranium and isotopic U-235 content of special nuclear material.

The above matters were brought to the attention of Messrs. R. E. Bish, B. Mills and J. Haymon of Westinghouse during the final meeting and they agreed to take appropriate corrective action. These matters will be reviewed during the next safeguards inspection of your facility.

The cooperation extended to the inspection team is appreciated.

Sincerely,

Original Signed by
R. P. Wischow

R. P. Wischow, Director
Division of Nuclear
Materials Safeguards

FEB 27 1969

cc: Mr. A. T. Sabo, Safety
and Industrial Hygiene Manager

e/254

| | | | | | | |
|-----------|--------------|----------|-----------|--|--|--|
| OFFICE ▶ | NMS | NMS:AD/O | NMS:D | | | |
| SURNAME ▶ | HVWerner/dlg | LCSoien | RPWischow | | | |
| DATE ▶ | 2/14/69 | 2/17/69 | 2/17/69 | | | |

ITEM # 252

(22)

UNITED STATES
ATOMIC ENERGY COMMISSION

OFFICE OF
DIRECTOR OF REGULATION
DIVISION OF
NUCLEAR MATERIALS SAFEGUARDS

report of the
**INSPECTION OF
SAFEGUARDS
CONTROL OF
NUCLEAR MATERIALS**
of

RIS: ZYP
License No.: SNM-338 Docket No.: 70-337

WESTINGHOUSE ELECTRIC CORPORATION
CHESWICK, PENNSYLVANIA

Inspection No.: SO-I-4
Inspection Date: November 6-15, 1968
Report Date: January 27, 1969

For The Period: Nov. 1, 1967 To: Oct. 31, 1968

DISTRICT I SAFEGUARDS OFFICE
NEWARK, NEW JERSEY

NUCLEAR MATERIALS SAFEGUARDS INSPECTION
OF SPECIAL NUCLEAR MATERIALS
WESTINGHOUSE ELECTRIC CORPORATION
CHESWICK, PENNSYLVANIA

1.0 INTRODUCTION

1.01 - An inspection of safeguards control over special nuclear material was made at the Cheswick site of Westinghouse Electric Corporation by the District I Safeguards Office, Division of Nuclear Materials Safeguards. The inspection covered the period of operation from November 1, 1967 through October 31, 1968, with the field work being done from November 6 through November 15, 1968. A pre-inspection visit was performed on October 23, 24, 1968.

1.02 - Description of Licensee's Facilities - The SNM activities carried out under AEC license No. 338 at the Cheswick site are performed within four material balance areas. Each area performs a separate function as follows:

- (a) MBA-3 - Analytical Laboratory - This area gives analytical support to fuel manufacturing and the development laboratory. Incoming shipments of UO_2 powder, manufactured pellets and generated scrap are assayed for Uranium, Uranium-235 content and impurities.
- (b) MBA-4 - Fuel Manufacturing - Pellets are fabricated from low enriched uranium oxide and are inserted into tubes to form rods. The rods are then assembled into elements for use in power reactors. To date the facility does not have the capability to convert UF_6 to UO_2 or reclaim uranium from scrap. These services are obtained through contracts with other licensees.
- (c) MBA-5 - Development Laboratory - At this area, new techniques of fuel fabrication are developed and tested for possible use by fuel manufacturing. On a pilot plant scale, the capabilities at the development laboratory are similar to those at fuel manufacturing.
- (d) MBA-6 - Plutonium Laboratory - At this MBA, techniques to manufacture reactor fuel rods containing ceramic plutonium pellets are developed and tested. Uranium, plutonium, and carbide mixtures have been studied during the inspection period.
- (e) A plutonium facility at the Cheswick site is scheduled for completion and start-up during the early part of 1969. The facility is awaiting license approval. Operations at the plutonium facility will consist of manufacturing of ceramic plutonium fuel for power reactors. Plutonium nitrate will be converted to oxide and scrap will be recovered at the facility. It is anticipated that the plutonium inventory will exceed 100 kilograms when the plant is in full operation.

2.0 SCOPE

2.01 - The inspection was made to determine the adequacy of Westinghouse Electric Corporation, Cheswick, Pennsylvania conformance to requirements contained in Title 10, Code of Federal Regulations, Part 70, "Special Nuclear Material" and specific requirements contained in License No. SNM-338.

2.02 - The licensee's safeguards controls were reviewed for inventory procedures and identification practices, measurements, statistics, loss mechanisms, internal control, records and reports, material unaccounted for, accidental losses, normal operational losses and shipper/recipient differences. In addition, the inspection team observed the taking of the physical inventory and performed such checks as necessary to verify the statement of inventory.

2.03 - There was no observation of physical protection practices utilized by the licensee in connection with unclassified special nuclear material since this was not required at the time of the inspection.

3.0 CONCLUSIONS

3.01 - The licensee is in compliance with 10 CFR 70 and his licensee requirements.

3.02 - The following deficiencies were brought to the attention of management personnel at MBA-4:

- (a) It was noted that during the inspection period there were seven adjustments to the book inventory which were identified by the licensee as either process loss or material unaccounted for. These adjustments were not made as a result of a physical inventory but rather as a periodic adjustment to the physical inventory based upon an assumption that when a job was completed 0.5% of the material utilized for a job would be in the material unaccounted for category.
- (b) Samples of incoming virgin UO_2 powder, UO_2 pellets and sludges are forwarded to an on-site analytical laboratory (MBA-3) for analyses of impurities, uranium and U-235 content. The analytical results for the pellets and sludges are used for inventory purposes. The results of the virgin UO_2 analyses are used to confirm shippers values. It was noted that standards were not periodically analyzed by the laboratory personnel to serve as a check as to the validity of measurements performed of virgin powder and pellets. Also there was no evaluation as to the precision of any of the measurements.

Westinghouse management agreed to take corrective actions on the two deficiencies.

3.03 - No comment concerning the adequacy of the licensee's physical protection practices since these were not observed during the inspection.

4.0 DISCUSSION

4.01 - Requirements of 10 CFR 70

- (a) Westinghouse Electric Corporation - The licensee submitted a Fundamental Material Control Manual and a detailed procedures manual for license SNM-338 on November 1, 1968. The information contained in these manuals was incomplete and additional information is needed to complete the license conditions. A new submittal date of January 15, 1969 was established.
- (b) Westinghouse Electric Corporation has confined the possession and use of special nuclear material to the locations and purposes authorized in the license as required 10 CFR 70.41.
- (c) The licensee has not transferred special nuclear material except to an authorized recipient as required by 10 CFR 70.42.
- (d) The licensee has kept records showing the receipt, inventory (including location), disposal, acquisition, import, export, and transfer of all special nuclear material in his possession as required by 10 CFR 70.51.
- (e) The licensee has established and maintains written material control procedures as required by 10 CFR 70.51(b)(1).
- (f) The licensee conducts a physical inventory as required by 10 CFR 70.51(b)(2).
- (g) The licensee had no losses that required reporting under 10 CFR 70.52.
- (h) The licensee has submitted material status reports on June 30, 1968 as required by 10 CFR 70.53.
- (i) The licensee has properly executed transfer reports on shipments and receipts as required by 10 CFR 70.54.

4.02 - License Limitations

- (a) Westinghouse Electric Corporation License No. SNM-338 has authorized limits of 10,010 kg U-235 and 37.5 kg Pu.

(b) On 10/31/68 the following was in possession of the licensee:

| <u>MBA</u> | <u>Uranium</u> | <u>U-235</u> | <u>Pu</u> |
|--------------|----------------------|-------------------|-------------------|
| 3 | included in MBA 4 | | |
| 4 | 106,189.6 kgs | 3130.8 kgs | -- |
| 5 | 495.3 kgs | 39.0 kgs | 1260 grams |
| 6 | <u>10.1 kgs</u> | <u>9.4 kgs</u> | <u>4025 grams</u> |
| <u>TOTAL</u> | <u>106,695.0 kgs</u> | <u>3179.2 kgs</u> | <u>5285 grams</u> |

4.03 - Inventory and Inventory Verification - The inventory was located in four material balance areas at the Cheswick site and was under the control of different MBA custodians and management. Each MBA was inspected by the team as follows:

(a) MBA-4 Fuel Manufacturing

More than 99% of the material under SNM-338 was located in this MBA. The material consisted of low enriched uranium in the form of virgin UO₂ powder, inprocess pellets, completed pellets, single fuel rods, assemblies, scrap pellets, grinder sludge, and filters. Each item or groups of items were recorded by inventory clerks on Westinghouse pre-numbered inventory sheets. Separate sheets were allocated to specific jobs.

A numbered inventory tag was placed on the item as it was recorded and the inventory tag number was recorded on the inventory sheet. The inspection team observed the taking of the inventory. Each recorded inventory item was initialled by an inspection team member. After all inventory items were listed, the areas were inspected to determine whether all items had been included. Control of the original inventory sheets were maintained by members of the inspection team until copies were made. A copy of the original inventory sheets was used by the inspection team to allocate the items into four groups; Category I, Category III, Single rods and Category V.

Category I items consisted of virgin UO₂ powder and pellets.

Category III items consisted of scrap pellets and sludges.

Material under "Category V" consisted of completed fuel assemblies, items that contained negligible quantities of uranium (<10g), absolute air filters, retainer samples, and quality control standards. Samples from Category I, III and fuel rods were withdrawn at random. The number of items withdrawn were such to give at least a 95%-90% certification statement

if all met the inspection team acceptance criteria. Items selected from Category I and III were weighed, sampled, and analyzed for U-235 content by the inspection team using the portable gamma spectrometer. The inspection team used District I powder and pellet standards to determine U-235 content of these samples.

Fuel rods were also analyzed for U-235 content using as standards fuel rods prepared by the licensee. The inspection team witnessed the preparation of the rods to be used as standards.

The U-235 content of fuel assemblies was verified by inspection of supporting quality control data. Material in assemblies amounted to 26,890 kg U and 803.7 kg U-235.

After the taking of the inventory, the licensee assigned uranium and uranium 235 data to each of the inventory items. A conversion factor sheet prepared by the licensee which identified the uranium and uranium 235 factor for each type of material was used for this purpose. The factors used were determined by quality control measurements. The inspection team reviewed the supporting quality control data of each of the factors. The item extensions, page summaries and job totals were checked by the inspection team, after the licensee had summarized the inventory for each job.

(b) MBA-5 Development Laboratory

The physical inventory in this area consisted of low enriched uranium in the form of pellets, powders, fuel pins, sludges and mounted samples. The licensee had taken a prior inventory of material in this area. Each of the items listed was observed by the inspection team. After the inspection of the entire inventory, all items excluding the fuel pins and plastic sample mounts were placed in a Category for weighing and sampling of a random selection of enough items so that at least a 95%-90% certification statement for the Category could be derived. The samples withdrawn were verified for U-235 content by the inspection team using the portable gamma spectrometer and inspection team standards.

The inventory summary and supporting sheets were checked for accuracy.

(c) MBA-6 Plutonium Facility

All inventory items were pre-listed by the licensee. Each of the items was observed by the inspection team. The items were in the form of virgin plutonium metal, virgin enriched uranium metal and uranium and plutonium carbide mixtures.

A decision was made by the inspection team to forgo a certification statement at this MBA because the quantity of material at the MBA approximated 5000 grams of special nuclear material. In order to accomplish a 95%-90% certification statement, 22 plutonium samples would be needed. The inspection team estimated that observation of sampling and assay would require at least 2 man weeks of effort. In lieu of sampling to provide a certification statement, 6 judgement samples were withdrawn. Four of the samples were from mixtures of plutonium, two of the samples were from enriched uranium metal. The six samples were forwarded to the New Brunswick Laboratory for assay. The NBL results indicated that each of the items met their respective Category acceptance criteria.

Fourteen samples which were assayed by the inspection team were forwarded to the New Brunswick Laboratory as a check on the inspection team gamma measurements. A comparison of the inspection team results and that of the New Brunswick Laboratory indicated that there was no significant difference at the 95% level of confidence between the measurement systems.

The summary of inventory verification and certification statements for the populations tested appear in EXHIBITS I - III of this report.

4.04 - Measurements - The analytical laboratory performs uranium and uranium 235 analyses of samples forwarded from the development laboratory and fuel manufacturing. Uranium assay of U_3O_8 and UO_2 powders are performed by the ignition method and the results are reported to four significant figures. Standards are not analyzed along with these routine analyses. The laboratory manager indicated that a check was performed a couple of years ago against the volumetric ceric sulfate and dichromate titration methods which were routinely run with standards. The ignition method was found to be biased about 0.1% higher than the titration methods.

The ceric sulfate or dichromate method is used for sludges and other impure materials. NBS standard 950A is analyzed whenever these materials are assayed. However, the results of the standard are not used to determine the laboratory's precision.

A Jarrel Ash emission spectrograph is used to determine isotopic content of uranium. A licensee prepared standard is run with the unknown. The results are reported to two significant figures. No evaluation has been made of the precision of the measurement.

Plutonium assays are not performed on a routine basis. Management at the plutonium facility indicated that when Pu assays are performed they use methods outlined in "Selected Measurement Methods".

Scales and balances are checked routinely by quality control with NBS standard weights. The inspection team noted that standards were available at each weighing area and that each scale and balance had an inspection label which indicated the last inspection data. All scales and balances used by the inspection team were checked prior to use in the weighing of items to be verified.

4.05 - Statistics - There was no evidence of the use of statistics to determine weighing errors; the precision of analytical measurements, the expected MUF on a job, the MUF for a material balance area, a significant shipper/receiver difference, or an excessive normal operational loss.

4.06 - Loss Mechanisms - The loss mechanism review was performed by completion of the loss mechanism questionnaire with representatives of health physics. The inspection team noted that all side streams where small quantities of material are discarded such as floor moppings, clothes to the laundry, gloves and rags are measured by health physics using counting techniques. Monthly reports were issued by health physics to material balance custodians indicating the quantity of uranium in the normal operational losses. The material balance area custodian assigns an isotopic value to the uranium discarded based upon the job in production for the month in which the loss occurred.

4.07 - Internal Control - The internal control review was performed by completion of the internal control questionnaire by the inspection team. The inspection team did not note any deficiencies in internal control practices.

4.08 - Records & Reports - The inspection at Westinghouse Electric Corporation of SNM-338 special nuclear material records and reports for period under review consisted of:

- (a) an examination of the flow of Westinghouse special nuclear material shipping and receiving documents through the various control records, reports; and through the material balance area records and reports.
- (b) preparation of a special nuclear material documents, reports, and records flow chart to reflect the overall control by the licensee SS representative of data received by his office and the results of operation which are reported to the Atomic Energy Commission and Westinghouse Management.
- (c) preparation of a special nuclear material documents, reports, and records flow chart to reflect the overall control by the material balance area clerks over special nuclear material and the reconciliation of MBA accounts with the SS representative control accounts.
- (d) preparation of a summary of special nuclear material transactions covering receipts, removals, losses and book inventory of selected contracts for the period May 1, 1967 through October 31, 1968. This summary was primarily for the use of the technical members of the inspection team.

- (e) preparation of a special nuclear material inventory schedule for leased and privately owned special nuclear materials as of October 31, 1968. This schedule was reconciled to the physical inventory.
- (f) an examination of Westinghouse privately owned material general journal and project control ledger. This examination consisted of reviewing internal and external transfer documents for accuracy and correctness, and tracking the quantities through the books of original entry to the final reports which were sent to the Atomic Energy Commission and Westinghouse Management.
- (g) preparation of a Material Status Reports and Material Balance Reports covering the period of November 1, 1967 through October 31, 1968. See EXHIBITS IV through IX for details.
- (h) an examination of the forms, reports, and accounting procedures maintained to document and control special nuclear material at the various material balance areas.

The Westinghouse Electric Corporation records, reports, and accounting procedures regarding special nuclear materials held under License 338 did meet AEC requirements. The reports which were sent to the Atomic Energy Commission reliably reflect the activity for the period under review.

4.09 - Material Unaccounted For (MUF) - The total MUF declared by the licensee during the inspection period was 714 kg U and 18 kg U-235. The MUF represented 0.52% of the total receipts for the period. The inspection team noted that all MUF's were not the result of a physical inventory and that MUF's were arbitrarily declared at some point during the fabrication of a job. As a result of the physical inventory the book physical difference amounted to a gain of 75.9 kg U and 2.6 kg U-235. The licensee adjusted the job accounts to agree with the physical inventory.

4.10 - Accidental Losses - There were no accidental losses of material during the inspection period.

4.11 - Normal Operational Losses - The total normal operational loss taken during the inspection period amounted to 24.9 kg U and 0.8 kg U-235. The losses were the result of discarded floor wash water, baled waste, and clothing to the laundry. All of the losses were supported by measurements, however, there were no evidence of limits of error associated with the measurements.

4.12 - Shipper Receiver Differences - There were no shipper/receiver differences during the inspection period.

4.13 - Physical Protection Practices - There was no observation of physical protection practices utilized by the licensee in connection with unclassified special nuclear material since this was not required at the time of the inspection.

DATE OF REPORT: January 27, 1969

TEAM LEADER:





Director, District I
Safeguards Office

EXHIBITS:

- I - SUMMARY OF INVENTORY VERIFICATION
- II - CHECK WEIGHING AND U-235 - ATTRIBUTE CERTIFICATION
- III - U-235 BY GAMMA COUNT - ESTIMATION CERTIFICATION
- IV - MATERIAL STATUS REPORT (PLUTONIUM (LEASED))
- V - MATERIAL STATUS REPORT (ENRICHED URANIUM (LEASED))
- VI - MATERIAL STATUS REPORT (ENRICHED URANIUM (PRIVATELY OWNED))
- VII - SPECIAL NUCLEAR MATERIALS HELD UNDER FACILITY MCY AND LICENSE 338
- VIII - SPECIAL NUCLEAR MATERIALS HELD UNDER FACILITY MCY AND LICENSE 338
- IX - SPECIAL NUCLEAR MATERIALS HELD UNDER FACILITY MCY AND LICENSE 338

EXHIBIT I
 WESTINGHOUSE ELECTRIC CORPORATION
 SNM 338
 CHESWICK, PENNSYLVANIA

SUMMARY OF INVENTORY VERIFICATION
 (based on licensee values)

Certification - Verified

| MBA | U kgs | U-235 kgs | Pu grams |
|-------|---------------|---------------|---------------|
| 3 & 4 | 83,178.2 | 2434.4 | -- |
| 5 | 420.6 | 36.8 | -- |
| 6 | <u> --</u> | <u> --</u> | <u> --</u> |
| TOTAL | 83,598.8 | 2471.2 | -- |

Non-Certification - Verified

| MBA | U kgs | U-235 kgs | Pu grams |
|-------|----------------|----------------|--------------|
| 3 & 4 | 26,889.5 | 803.7 | -- |
| 5 | -- | -- | -- |
| 6 | <u> 2.4</u> | <u> 2.3</u> | <u> 978</u> |
| TOTAL | 26,891.9 | 803.0 | 978 |

Licensee Inventory as of Verification date (1)

| MBA | U kgs | U-235 kgs | Pu grams |
|-------|-----------------|----------------|---------------|
| 3 & 4 | 110,206.9 | 3242.5 | -- |
| 5 | 495.3 | 39.0 | 1260 |
| 6 | <u> 10.1</u> | <u> 9.4</u> | <u> 4025</u> |
| TOTAL | 110,712.3 | 3290.9 | 5285 |

(1) Quantity of material differs from 10/31/68 inventory because of subsequent receipts of virgin powder which was verified and included in Categories.

EXHIBIT II
 WESTINGHOUSE ELECTRIC CORPORATION
 SNM-338
 CHESWICK, PENNSYLVANIA

CHECK WEIGHING AND U-235 - ATTRIBUTE CERTIFICATION

| <u>AEC-Lic.</u> | <u>No. of Weight Rejects</u> | <u>(1) Weight Cert. Level</u> | <u>AEC Gms in sample U-235</u> | <u>Lic. Gms. in sample U-235</u> | <u>AEC-Lic. Gms in sample U-235</u> | <u>No. of % Isotopic Rejects</u> | <u>(1) U-235 Cert. Level</u> |
|-----------------|--------------------------------------|---|--|--|---|--|--------------------------------------|
| 51 | 1 | 91 | 16,279 | 16,579 | -300 | 1 | 91 |
| 40 | 1 | 85 | 11,717 | 11,898 | -181 | 0 | 90 |
| - | - | -- | 3,914 | 3,868 | 46 | - | -- |
| -3 | 1 | 85 | 7,341 | 7,250 | 91 | 1 | 85 |

fine SS content

EXHIBIT III
 WESTINGHOUSE ELECTRIC CORPORATION
 SNM-338
 CHESWICK, PENNSYLVANIA

BY GAMMA COUNT-ESTIMATION CERTIFICATION BY-DIFFERENCE

| <u>Lic. total Gms U-235 Category</u> | <u>No. of items in sample n</u> | <u>\bar{d} Gms U-235</u> | <u>Limits of Error of \bar{d} Gms U-235</u> | <u>$n \bar{d}$ Gms U-235</u> | <u>Lic. Total Gms U-235 in items sampled</u> |
|--|---|---|--|---|--|
| 20,580 | 64 | 0.7 | $\pm .3$ | 46 | 3,868 |
| 145,451 | 52 | -5.8 | ± 5.7 | -300 | 16,579 |
| 68,581 | 32 | -5.7 | ± 8.3 | -181 | 11,898 |
| 36,128 | 32 | 2.8 | $\pm .6$ | 91 | 7,250 |

s sampled.

EXHIBIT IV
UNITED STATES ATOMIC ENERGY COMMISSION
MATERIAL STATUS REPORT

FOR SPECIAL NUCLEAR MATERIALS HELD UNDER LICENSE
PREPARE A SEPARATE REPORT FOR EACH LICENSE

RIS - ZYP

| | | | |
|--|-------------------------|------------------------------------|------------------------|
| 1. REPORTING LICENSEE: WESTINGHOUSE ELECTRIC CORPORATION | | c. License No. SNM-338 | |
| a. Name | | d. Period Ending 10/31/68 | |
| b. Address BOX 355, PITTSBURGH, PA. 15230 | | | |
| 2. MATERIAL: (Prepare separate report for each material) PLUTONIUM (LEASES) | 3. WEIGHT UNIT GRAMS | 4. TOTAL QUANTITY AND ISOTOPE DATA | |
| 5. BEGINNING INVENTORY: 11/1/67 | | a. ELEMENT 1,617.94 | b. ISOTOPE 1,479.22 |
| 6. RECEIPTS: | | | |
| From | Shipper's License No. | | |
| | | | |
| | | | |
| | | | |
| 7. TOTAL RECEIPTS | | 125.52 | 114.68 |
| 8. PRODUCTION | | | |
| 9. MATERIAL TO BE ACCOUNTED FOR (Total of lines 5, 7, and 8). | | 1,743.46 | 1,593.90 |
| 10. SHIPMENTS: | | | |
| To | Consignee's License No. | | |
| | | | |
| | | | |
| | | | |
| 11. TOTAL SHIPMENTS | | 221.83 | 202.65 |
| 12. PROCESSING LOSSES, DISCARDS, ETC.: | | | |
| a. MATERIAL FOR WHICH THE REPORTING LICENSEE IS FINANCIALLY RESPONSIBLE | | 10.00 | 9.00 |
| b. MATERIAL FOR WHICH THE REPORTING LICENSEE IS NOT FINANCIALLY RESPONSIBLE | | (125.53) | (114.69) |
| 13. BURN-UP | | | |
| 14. ENDING INVENTORY 10/31/68 | | 1,637.16 | 1,496.94 |
| 15. MATERIAL ACCOUNTED FOR (Total of lines 11, 12a, 12b, 13 and 14). | | 1,743.46 | 1,593.90 |
| 16. DETAIL OF ENDING INVENTORY: | | | |
| a. MATERIAL ON HAND FOR WHICH REPORTING LICENSEE IS FINANCIALLY RESPONSIBLE TO THE AEC UNDER ABOVE LICENSE. | | 281.95 | 258.72 |
| b. MATERIAL ON HAND FOR WHICH SOMEONE OTHER THAN REPORTING LICENSEE IS FINANCIALLY RESPONSIBLE TO THE AEC (Detail below) | | | |
| Name | License No. | | |
| Westinghouse | 783 | 1,355.21 | 1,238.22 |
| | | | |
| | | | |
| c. Total of a. and b. | | 1,637.16 | 1,496.94 |
| 17. MATERIAL IN POSSESSION OF OTHERS FOR WHICH REPORTING LICENSEE IS FINANCIALLY RESPONSIBLE TO THE AEC UNDER ABOVE LICENSE (Detail below) | | | |
| Name | Possessor's License No. | | |
| | | | |
| | | | |
| | | | |
| TOTALS | | | |

COMPOSITION OF ENDING INVENTORY

| FORM OF MATERIAL | ELEMENT | % OF ISOTOPE CONTAINED | ISOTOPE | REMARKS |
|---|----------|------------------------|----------|---------|
| 18. COMPOSITION OF ITEM 16a. | | | | |
| | | | | |
| | | | | |
| | | | | |
| | | | | |
| | | | | |
| | | | | |
| TOTAL | 281.95 | | 258.72 | |
| 19. COMPOSITION OF ITEM 16b. | | | | |
| | | | | |
| | | | | |
| | | | | |
| | | | | |
| | | | | |
| | | | | |
| TOTAL | 1,355.21 | | 1,238.22 | |
| 20. TOTAL INVENTORY ON HAND (Total of Items 18 and 19). | | | | |
| | 1,637.16 | | 1,496.94 | |
| 21. COMPOSITION OF ITEM 17. | | | | |
| | | | | |
| | | | | |
| | | | | |
| | | | | |
| | | | | |
| | | | | |
| TOTAL | | | | |
| <p>22. TO THE BEST OF MY KNOWLEDGE AND BELIEF THE INFORMATION GIVEN ABOVE AND IN THE ATTACHED SCHEDULES, IF ANY, IS TRUE, COMPLETE, AND CORRECT.</p> <p> <u>12/5/68</u> (Date) <u><i>A. J. Bearden</i></u> (Signature and Title) </p> | | | | |

18 U.S.C., SECTION 1001, ACT OF JUNE 25, 1948, 62 STAT. 749, MAKES IT A CRIMINAL OFFENSE TO MAKE A WILLFULLY FALSE STATEMENT OR REPRESENTATION TO ANY DEPARTMENT OR AGENCY OF THE UNITED STATES OR TO ANY MATTER WITHIN ITS JURISDICTION.

MATERIAL STATUS REPORT

FOR SPECIAL NUCLEAR MATERIALS HELD UNDER LICENSE
PREPARE A SEPARATE REPORT FOR EACH LICENSE

RIS - ZYP

| | | | |
|--|-------------------------------|------------------------------------|------------|
| 1. REPORTING LICENSEE: WESTINGHOUSE ELECTRIC CORPORATION | | c. License No. SNM-338 | |
| a. Name: _____ | | d. Period Ending 10/31/68 | |
| b. Address: BOX 355, PITTSBURGH, PA. 15230 | | | |
| 2. MATERIAL: (Prepare separate report for each material) ENRICHED URANIUM (LEASED) | 3. WEIGHT UNIT GRAMS | 4. TOTAL QUANTITY AND ISOTOPE DATA | |
| | | a. ELEMENT | b. ISOTOPE |
| 5. BEGINNING INVENTORY: 11/1/67 | | 20,031,645 | 864,558 |
| 6. RECEIPTS: | | | |
| From _____ | Shipper's License No. _____ | | |
| _____ | _____ | | |
| _____ | _____ | | |
| _____ | _____ | | |
| 7. TOTAL RECEIPTS | | 114,767,745 | 3,442,839 |
| 8. PRODUCTION | | | |
| 9. MATERIAL TO BE ACCOUNTED FOR (Total of lines 5, 7, and 8). | | 134,799,390 | 4,307,397 |
| 10. SHIPMENTS: | | | |
| To _____ | Consignee's License No. _____ | | |
| _____ | _____ | | |
| _____ | _____ | | |
| _____ | _____ | | |
| 11. TOTAL SHIPMENTS | | 43,410,833 | 1,659,987 |
| 12. PROCESSING LOSSES, DISCARDS, ETC.: | | | |
| a. MATERIAL FOR WHICH THE REPORTING LICENSEE IS FINANCIALLY RESPONSIBLE | | 462,236 | 11,567 |
| b. MATERIAL FOR WHICH THE REPORTING LICENSEE IS NOT FINANCIALLY RESPONSIBLE | | (22,266) | (343) |
| 13. BURN-UP | | | |
| 14. ENDING INVENTORY 10/31/68 | | 90,948,587 | 2,636,186 |
| 15. MATERIAL ACCOUNTED FOR (Total of lines 11, 12a, 12b, 13 and 14). | | 134,799,390 | 4,307,397 |
| 16. DETAIL OF ENDING INVENTORY: | | | |
| a. MATERIAL ON HAND FOR WHICH REPORTING LICENSEE IS FINANCIALLY RESPONSIBLE TO THE AEC UNDER ABOVE LICENSE. | | 90,939,399 | 2,635,633 |
| b. MATERIAL ON HAND FOR WHICH SOMEONE OTHER THAN REPORTING LICENSEE IS FINANCIALLY RESPONSIBLE TO THE AEC (Detail below) | | | |
| Name JOB DGRF 302-1 | License No. _____ | 9,188 | 553 |
| _____ | _____ | | |
| _____ | _____ | | |
| _____ | _____ | | |
| c. Total of a. and b. | | 90,948,587 | 2,636,186 |
| 17. MATERIAL IN POSSESSION OF OTHERS FOR WHICH REPORTING LICENSEE IS FINANCIALLY RESPONSIBLE TO THE AEC UNDER ABOVE LICENSE (Detail below) | | | |
| Name _____ | Possessor's License No. _____ | | |
| _____ | _____ | | |
| _____ | _____ | | |
| _____ | _____ | | |
| TOTALS | | | |

COMPOSITION OF ENDING INVENTORY

| FORM OF MATERIAL | ELEMENT | % OF ISOTOPE CONTAINED | ISOTOPE | REMARKS |
|--|------------|------------------------|-----------|---------|
| 18. COMPOSITION OF ITEM 16a. | | | | |
| | | | | |
| | | | | |
| | | | | |
| | | | | |
| | | | | |
| | | | | |
| TOTAL | 90,939,399 | | 2,635,633 | |
| 19. COMPOSITION OF ITEM 16b. | | | | |
| | | | | |
| | | | | |
| | | | | |
| | | | | |
| | | | | |
| | | | | |
| TOTAL | 9,188 | | 553 | |
| 20. TOTAL INVENTORY ON HAND (Total of Items 18 and 19). | | | | |
| | 90,948,587 | | 2,636,186 | |
| 21. COMPOSITION OF ITEM 17. | | | | |
| | | | | |
| | | | | |
| | | | | |
| | | | | |
| | | | | |
| | | | | |
| TOTAL | | | | |

22. TO THE BEST OF MY KNOWLEDGE AND BELIEF THE INFORMATION GIVEN ABOVE AND IN THE ATTACHED SCHEDULES, IF ANY, IS TRUE, COMPLETE, AND CORRECT.

12/5/68 *A. J. Braden*

(Date) (Signature and Title)

18 U.S.C., SECTION 1001, ACT OF JUNE 25, 1948, 62 STAT. 749, MAKES IT A CRIMINAL OFFENSE TO MAKE A WILLFULLY FALSE STATEMENT OR REPRESENTATION TO ANY DEPARTMENT OR AGENCY OF THE UNITED STATES OR TO ANY MATTER WITHIN ITS JURISDICTION.

EXHIBIT VI
UNITED STATES ATOMIC ENERGY COMMISSION
MATERIAL STATUS REPORT

FOR SPECIAL NUCLEAR MATERIALS HELD UNDER LICENSE
PREPARE A SEPARATE REPORT FOR EACH LICENSE

RIS - ZYP

| | |
|---|------------------------------------|
| 1. REPORTING LICENSEE: a. Name <u>WESTINGHOUSE ELECTRIC CORPORATION</u> c. License No. <u>SNM-338</u> b. Address <u>BOX 355, PITTSBURGH, PA. 15230</u> d. Period Ending <u>10/31/68</u> | |
| 2. MATERIAL: (Prepare separate report for each material) <u>ENRICHED URANIUM (PRIVATELY OWNED)</u> | 3. WEIGHT UNIT <u>GRAMS</u> |
| 4. TOTAL QUANTITY AND ISOTOPE DATA | |
| a. ELEMENT | b. ISOTOPE |
| -- | -- |
| 5. BEGINNING INVENTORY: <u>11/1/67</u> | |
| 6. RECEIPTS: | |
| From _____ Shipper's License No. _____ | |
| _____ | |
| _____ | |
| 7. TOTAL RECEIPTS | |
| 8. PRODUCTION | <u>42,775,297</u> <u>1,229,664</u> |
| 9. MATERIAL TO BE ACCOUNTED FOR (Total of lines 5, 7, and 8). | <u>42,775,297</u> <u>1,229,664</u> |
| 10. SHIPMENTS: | |
| To _____ Consignee's License No. _____ | |
| _____ | |
| _____ | |
| 11. TOTAL SHIPMENTS | <u>26,916,213</u> <u>693,571</u> |
| 12. PROCESSING LOSSES, DISCARDS, ETC. | |
| a. MATERIAL FOR WHICH THE REPORTING LICENSEE IS FINANCIALLY RESPONSIBLE | <u>NONE</u> |
| b. MATERIAL FOR WHICH THE REPORTING LICENSEE IS NOT FINANCIALLY RESPONSIBLE | <u>163,809</u> <u>3,625</u> |
| 13. BURN-UP | |
| 14. ENDING INVENTORY <u>10/31/68</u> | <u>15,695,275</u> <u>532,468</u> |
| 15. MATERIAL ACCOUNTED FOR (Total of lines 11, 12a, 12b, 13 and 14). | <u>42,775,297</u> <u>1,229,664</u> |
| 16. DETAIL OF ENDING INVENTORY: | |
| a. MATERIAL ON HAND FOR WHICH REPORTING LICENSEE IS FINANCIALLY RESPONSIBLE TO THE AEC UNDER ABOVE LICENSE. | |
| b. MATERIAL ON HAND FOR WHICH SOMEONE OTHER THAN REPORTING LICENSEE IS FINANCIALLY RESPONSIBLE TO THE AEC (Detail below) | |
| Name _____ License No. _____ | |
| <u>Swiss Owned</u> | <u>15,695,275</u> <u>532,468</u> |
| _____ | |
| _____ | |
| c. Total of a. and b. | <u>15,695,275</u> <u>532,468</u> |
| 17. MATERIAL IN POSSESSION OF OTHERS FOR WHICH REPORTING LICENSEE IS FINANCIALLY RESPONSIBLE TO THE AEC UNDER ABOVE LICENSE (Detail below) | |
| Name _____ Possessor's License No. _____ | |
| _____ | |
| _____ | |
| TOTALS | |

COMPOSITION OF ENDING INVENTORY

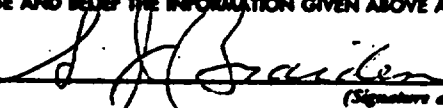
| FORM OF MATERIAL | ELEMENT | % OF ISOTOPE CONTAINED | ISOTOPE | REMARKS |
|--|---|------------------------|---------|---------|
| 18. COMPOSITION OF ITEM 16a. | | | | |
| | | | | |
| | | | | |
| | | | | |
| | | | | |
| | | | | |
| | | | | |
| TOTAL | | | | |
| 19. COMPOSITION OF ITEM 16b. | | | | |
| Swiss | 15,695,275 | | 532,468 | |
| | | | | |
| | | | | |
| | | | | |
| | | | | |
| TOTAL | 15,695,275 | | 532,468 | |
| 20. TOTAL INVENTORY ON HAND <i>(Total of Items 18 and 19).</i> | | | | |
| 21. COMPOSITION OF ITEM 17. | | | | |
| | | | | |
| | | | | |
| | | | | |
| | | | | |
| | | | | |
| | | | | |
| TOTAL | | | | |
| 22. TO THE BEST OF MY KNOWLEDGE AND BELIEF THE INFORMATION GIVEN ABOVE AND IN THE ATTACHED SCHEDULES, IF ANY, IS TRUE, COMPLETE, AND CORRECT. | | | | |
| 12/5/68 <i>(Date)</i> |  <i>(Signature and Title)</i> | | | |

18 U.S.C., SECTION 1001, ACT OF JUNE 25, 1948, 62 STAT. 749, MAKES IT A CRIMINAL OFFENSE TO MAKE A WILLFULLY FALSE STATEMENT OR REPRESENTATION TO ANY DEPARTMENT OR AGENCY OF THE UNITED STATES OR TO ANY MATTER WITHIN ITS JURISDICTION.

EXHIBIT VII

WESTINGHOUSE ELECTRIC CORPORATION
 SNM-338
 CHESWICK, PENNSYLVANIA

SPECIAL NUCLEAR MATERIALS HELD UNDER FACILITY MCY AND LICENSE 338

Material: Plutonium

| | <u>Element</u> | <u>Grams</u> | <u>Isotope</u> |
|-----------------------------|----------------|--------------|----------------|
| Beginning Inventory 11/1/67 | 1874 | | 1713 |
| Receipts | <u>1943</u> | | <u>1776</u> |
| Material To Account For | <u>3817</u> | | <u>3489</u> |
| Removals | 76 | | 69 |
| Material Unaccounted For | 93 | | 85 |
| Inventory 10/31/68 | <u>3648</u> | | <u>3335</u> |
| Material Accounted For | <u>3817</u> | | <u>3489</u> |

EXHIBIT VIII

WESTINGHOUSE ELECTRIC CORPORATION
 SNM-338
 CHESWICK, PENNSYLVANIA

SPECIAL NUCLEAR MATERIALS HELD UNDER FACILITY MCY AND LICENSE 338

Material: Enriched Uranium Under 75%

| | <u>Element</u> | <u>Grams</u> | <u>Isotope</u> |
|-----------------------------|----------------|--------------|----------------|
| Beginning Inventory 11/1/67 | 48420 | | 2661 |
| Receipts | <u>-0-</u> | | <u>-0-</u> |
| Material To Account For | <u>48420</u> | | <u>2661</u> |
| Removals | 6164 | | 398 |
| Processing Loss, MUF, Etc. | | | |
| Normal Processing Loss | 25 | | 1 |
| Materials Unaccounted For | <u>111</u> | | <u>18</u> |
| TOTAL | <u>136</u> | | <u>19</u> |
| Inventory 10/31/68 | <u>42120</u> | | <u>2244</u> |
| Material Accounted For | <u>48420</u> | | <u>2661</u> |

EXHIBIT IX

WESTINGHOUSE ELECTRIC CORPORATION
 SNM-338
 CHESWICK, PENNSYLVANIA

SPECIAL NUCLEAR MATERIALS HELD UNDER FACILITY MCY AND LICENSE 338

Material: Enriched Uranium Over 75%

| | <u>Element</u> | <u>Grams</u> | <u>Isotope</u> |
|-----------------------------|----------------|--------------|----------------|
| Beginning Inventory 11/1/67 | 9134 | | 8506 |
| Receipts | <u>-0-</u> | | <u>-0-</u> |
| Material To Account For | <u>9134</u> | | <u>8506</u> |
| Removals | 162 | | 150 |
| Material Unaccounted For | (2) | | (1) |
| Inventory 10/31/68 | <u>8974</u> | | <u>8357</u> |
| Material Accounted For | <u>9134</u> | | <u>8506</u> |

Handwritten:
~~WNB. 4/28/71~~
WNB. 8/20

NMS:FJM
70-337

SNM 338

AUG 9 1971

HP

Westinghouse Electric Corporation
Attn: Karl R. Schendel
License Administrator
P. O. Box 355
Pittsburgh, Pennsylvania 15230

Gentlemen:

We have received a copy of your May 11, 1971 letter from Mr. D. Haymon of your Columbia facility; our records do not indicate that we received the original correspondence. The following is in response to your request that we clarify our position with respect to the results of our October 1970 inspection of your Cheswick facilities.

The District I Safeguards Office (SO-I) inspectors did indicate in their report to Headquarters that as a result of their inspection certain deficiencies were noted in your materials control and that these deficiencies had been characterized as program weaknesses in their discussions with facility management. However, upon review by the Headquarters staff, it appeared that due to the existence of deficiencies it could not be concluded that you were fully complying with the conditions of your license. This review resulted in the April 28, 1971 letter to you.

The first item noted in our letter was discussed by Mr. Cohen, SO-I, with Messrs. Carroll, Foster and Tschiegg of your staff on October 30, 1971.

The second and third items noted in our letter were also discussed by Mr. Cohen with Messrs. Wiggins, Lang, Tschiegg and King of your staff on October 30, 1971.

Based on these discussions and our letter of April 28, 1971, it is our view that the deficiencies noted in your

9253

ITEM # 253

Handwritten:
I
③

Westinghouse Electric
Corporation

-2-

AUG 9 1971

materials control program as a result of our October 1970 inspection have been explicitly identified. Please inform us of the corrective actions you have taken or plan to take with respect to the noted deficiencies.

If you have any questions, please let me know.

Sincerely,

(Signed) C. D. W. Thornton

C. D. W. Thornton, Director
Division of Nuclear Materials
Safeguards

DISTRIBUTION

PDR, w/incoming
Docket 70-337, w/incoming
CKBeck, DR, w/o incoming
DLow, CO, w/o incoming
D:I, w/incoming
ECunningham, DML, w/incoming
LCrowson, SMM, w/incoming
GC, w/o incoming
HJMcAlduff, OR, w/incoming
SO-I, w/o incoming
NMS Reading, w/o incoming
NMS Case File, w/incoming
DR Reading, w/o incoming
VJD Reading, w/o incoming

| | | | | | | |
|-----------|---------|-----------|-------------|--|--|--|
| OFFICE ▶ | NMS | NMS | NMS | | | |
| SURNAME ▶ | IJMira | VJD'Amico | CDWThornton | | | |
| DATE ▶ | 7/29/71 | 8/2/71 | 8/4/71 | | | |

Westinghouse Electric Corporation

Power Systems

DOCKET NO. 70-337

PWR Systems Division

Box 355
Pittsburgh Pennsylvania 15221

EXTRA

May 11, 1971

U. S. Atomic Energy Commission
Division of Nuclear Materials Safeguards
Washington, D. C. 20545

Attention: Dr. C. D. W. Thornton, Director

Gentlemen:

Subject: USAEC Notification, Dated April 18, 1971,
Concerning License SMH-338, Docket 70-337

The Westinghouse Electric Corporation acknowledges receipt of your letter of April 28, 1971, on Docket 70-337. The letter does not correspond with our impressions of the results of the cited inspection, so I am writing to request that you clarify your position.

As you indicated in your letter, the inspection team discussed its findings with us on October 30, 1970, at Cheswick. District I personnel subsequently met with NFD Operations management at Columbia, South Carolina, in mid-December. At neither of these meetings was there any intent expressed by members of the inspection team to cite NFD for non-compliance. The team did "recommend" that the Safeguards Procedures Manual be strengthened in certain areas. The comments made last year by members of the inspection team provide no basis for interpreting the second and third items cited in your letter of this April.

Westinghouse constantly endeavors to conduct its operations in strict compliance with all pertinent local, state and federal requirements. We are prepared to determine and institute those suitable procedural changes which may be required to fulfill the USAEC regulations. However, in order to commence such activities, we would appreciate receiving explicit indications of those respects in which NFD Operations are deemed to be inadequate.

Please send your reply to me at the above address.

If you wish to discuss these matters, please telephone me at (412) 373-4647.

Very truly yours,

Karl R. Schendel

Karl R. Schendel

License Administrator

2129

Craker
~~NHB: [unclear]~~
WFL

JUN 25 1970

DISTRIBUTION

- PDR, w/incoming
- Docket 70-337, w/incoming
- C. L. Henderson, DR, w/incoming *HeP*
- L. D. Low, CO, w/incoming
- D. L. Crowson, SMM, w/incoming
- GC (2), w/incoming
- SO-I, w/incoming
- NMS Case File, w/incoming
- NMS Reading
- VJD Reading
- DR Reading

NMS:FJM
70-337

50427

Westinghouse Electric Corporation
P. O. Box 355
Pittsburg, Pennsylvania 15230

Attention: Dr. F. Forscher
Safeguards Coordinator
Nuclear Fuel Division

Gentlemen:

This is to acknowledge receipt of Mr. Foster's letter of June 15, 1970, and Dr. Jacoby and Mr. Shalek's letter of June 18, 1970.

Our District I Safeguards Office will review the corrective action outlined in the subject letters during the next safeguards inspection of your facility.

Sincerely,

Original Signed by
Ralph G. Page
Ralph G. Page
Acting Director
Division of Nuclear Materials
Safeguards

cc: H. Foster, Columbia, S.C.
P. Shalek, Cheswick, Pa.
W. Jacoby, Cheswick, Pa.

ITEM # 254

I *C/258*
(6)

| | | | | | |
|-----------|----------------|-----------------------|-----------------------|--|--|
| OFFICE ▶ | NMS <i>out</i> | NMS <i>[initials]</i> | NMS <i>[initials]</i> | | |
| SURNAME ▶ | FMRAGLIA:kb | VJDAMICO | RGPAGE | | |
| DATE ▶ | 6-25-70 | 6-25-70 | 6-25-70 | | |

Westinghouse Electric Corporation

Power Systems

Nuclear Fuel Division
Manufacturing Department

Box 5906
Columbia South Carolina 29205
(803) 776-2610

June 15, 1970

United States Atomic Energy Commission
Division of Nuclear Material Safeguards
Washington, D. C. 20545

Attention: Mr. Ralph G. Page, Acting Director

Subject: Nuclear Fuel Division Manufacturing Department Safeguards Data -
License SNM-338, Docket 70-337.

EXTRA

Gentlemen:

By letter dated April 15, 1970, from Dr. R. P. Wischow to Dr. F. Forscher, DNMS requested that Westinghouse inform them of the actions we "have taken or propose to take" with respect to some "discrepancies" which "exist" between our assigned inventory values on sludges and scrap, and values determined by extrapolating from AEC analytical data.

The application of stated Westinghouse limits of error to our values and the subsequent comparison of the two sets of values reveal that only 6 out of a total of 136 values exceed the variation which the limits of error predict. In addition, the statistical application of an equivalent limit of error assignable to the AEC data reduces the number of out-of-tolerance values to only two (2) values.

Westinghouse has investigated the source of both these samples. The results indicate that the material involved in each instance was a solidified "clinker" composed of sludge, floor sweepings, sink residues and other grossly contaminated scrap. The two samples represented a total of approximately 400 grams of 235U, and that no more than twice this quantity of SNM was present in this form in the entire inventory. Since the material had hardened, the sample obtained for the AEC in each instance represented only small pieces chipped from the surface of the clinker. Based on these considerations, Westinghouse attributes the discrepant values to the combined effects of the sampling technique used, and the use of a "standard" grinding sludge multiplier on a much more grossly contaminated material.

The use of these two "simplifying assumptions" was based on the economics of obtaining more realistic inventory values. The effort and expense of crushing, homogenizing, sampling and analyzing this material would be all out of proportion to the contribution it would make to the inventory accuracy. In addition, the material was grossly contaminated, low-enriched oxide which represented the ultimate in "nonstrategic-form" material.



The Westinghouse NFD Manufacturing Department proposes to evaluate the identification factors and limits of error which would apply to this material if it were to be segregated into a new, separate category during subsequent inventories. This category may be established and used during future inventories, provided that the quantities of SNM involved warrant the additional effort. For quantities of SNM comparable to those encountered in this inventory, the error introduced by the simplifying assumptions used during the inventory will be considered negligible.

If there are any further questions on this matter, please contact me at P. O. Box 5906, Columbia, South Carolina 29205.

Harold Foster
Harold Foster, Manager
Nuclear Material Safeguards

HF/cld

cc: J. O. Depree
NFD Controller

Dr. Frederick Forscher
NFD Safeguards Coordinator

D. J. Haymon, Manager
NFD Manufacturing Controls

R. E. Tschiegg, Manager
NES Nuclear Materials Management and Safeguards

K. R. Shendel
Headquarters - Licensing Administrator

W. G. Martin, Director
District 1 Safeguards

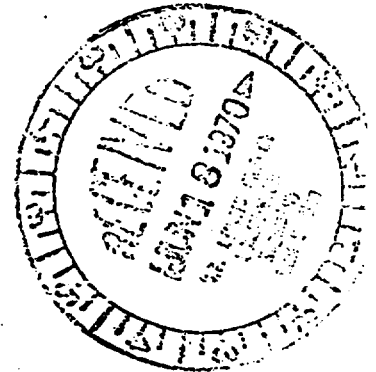



Westinghouse Electric Corporation

Power Systems

XXXXXXXXXXXXX
Advanced Reactors Division

Cheswick Site

Box 217, Cheswick, Pa. 15024

June 18, 1970

U. S. Atomic Energy Commission
Division of Nuclear Material Safeguards
Washington, D. C. 20545

Attention: Mr. Ralph G. Page, Acting Director

Gentlemen:

Subject: Advanced Reactors Division Safeguards
Data--License SNM-338, Docket 70-337

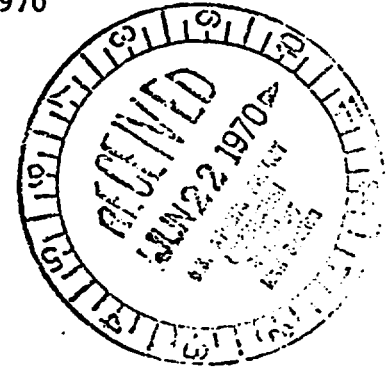

By letter dated April 15, 1970, from Dr. R. P. Wischow to Dr. F. Forscher, DNMS requested that Westinghouse inform them of the actions we "have taken or propose to take" with respect to some "discrepancies" which "exist" between our assigned inventory values on sludges and scrap, and values determined by extrapolation from AEC analytical data.

The application of conservative combined limits of error to our values and subsequent comparison of the two sets of values reveals that only six plutonium samples out of a total of 68 uranium and plutonium values exceed the variation which the limits of error predict.

Westinghouse has investigated the source of these six samples. In all instances, the discrepancies occurred in values assigned as the plutonium content of samples representing scrap material of random compositions. Two of the samples were grossly contaminated with analytical and grinding media, etc., so that they were not analyzed (4.7 grams Pu discrepancy where discrepancy equals the difference in excess of that predicted by the limit of error). Two more values were arbitrary selections of one laboratory's results over those from another. (See letter, dated 11/20/69, from P. D. Shalek to District I Safeguards Office for a discussion of the bases for choices between the results supplied by the two laboratories [2.0 grams Pu discrepancy]). The fifth value occurred in a batch that contained only about 1% Pu, which is at the low end of the range for the analytical method used, and the total quantity of Pu in the batch (approximately 0.5 gram) didn't warrant the expenditure

of time and effort in the analysis to obtain anything greater than a rough check (0.2 gram Pu discrepancy). The final sample represented material that was a combination of two different processing batches. The value assigned to the contents had been calculated using analytical data for each batch. This technique yielded acceptable results in several other instances, but for this lot an error apparently occurred in the proportion of each batch that was assumed to be present (4.4 grams Pu discrepancy).

Westinghouse takes the position that the accuracy of the plutonium inventory is acceptable, in view of the nature of the material under discussion, the total quantities of SNM involved, and their relation to the total inventory of SNM.

The discrepancies between Westinghouse nominal uranium enrichment values and AEC laboratory determinations caused concern. Nominal enrichment values were used for inventory purposes because all of the enriched uranium was procured as a single metal ingot. Only in a few instances had downgrading been detected and documented. We further reviewed our procedures in an attempt to determine whether the degradation of material that was indicated by NBL data was a physical possibility. The investigation revealed that the "worst" batches were the earlier ones when operators were still learning. Furthermore, there was one point in the process at which natural uranium pellets were deliberately inserted into the process stream. Credibly, if material were scrapped out after this point, natural uranium could be accidentally included in the scrap, resulting in downgraded uranium following oxidation and blending.

The Westinghouse ARD Plutonium Laboratory proposes the following actions to contribute to improve safeguards performance:

1. Scrap processing procedures will be modified specifically to prevent the inclusion of natural uranium with enriched uranium scrap.
2. The laboratory used for analytical data will participate in several qualifications or "round robin" programs (FFTF program, Idaho Falls program for umpire laboratories and the Office of Safeguards round robin). Advanced analytical techniques, more reliable limits of error, and similar improvements will stem from these activities.

3. Laboratory management will require a continuing high level of effort directed at maintaining a degree of control over scrap processing commensurate with the degree of control maintained over product processing.

If there are any further questions on this matter, please contact P. D. Shalek at (412) 363-8700, ext. 615.

Very truly yours,



P. D. Shalek
Safeguards Representative



W. R. Jacoby, Manager
ARD Cheswick Fuel Facility

tla

Enclosure

cc: Mr. Walter G. Martin, Director
Division of Nuclear Material Safeguards
District 1
U. S. Atomic Energy Commission
970 Broad Street
Newark, New Jersey 07102

NMS:FJM
70-337

SNM 338

MAR 28 1972

*Free
Relson*

Westinghouse Electric Corporation
Monroeville Nuclear Center
Attn: Mr. Karl R. Schendel
License Administrator
Box 355
Pittsburgh, Pennsylvania 15230

HP

Gentlemen:

Thank you for your letter of March 17, 1972, responding to the item of noncompliance discussed in our letter of February 28, 1972. We have reviewed your response and offer the following comments.

Your comment #1 cites lags between Federal postal system and freight deliveries as one factor which has hindered Westinghouse in reporting measurements within ten (10) days of receipt of material. Scheduled holidays and shutdowns are also cited as mitigating factors for failure to report within ten (10) days. It is for reasons such as these that the instructions for completing Form AEC-741 were changed by our letter of October 5, 1971, to require dispatch of the form on the same day of dispatch of shipments; thereby, providing receivers of material with timely notifications of special nuclear material shipped.

Paragraph 10 CFR 2.710, is contained in Subpart G which governs the procedure used in adjudications initiated by the issuance of an order, and does not prescribe a method for computing times for meeting other regulatory requirements. The requirement for completing and distributing Form AEC-741 in ten (10) days is not tied to any time computation method which excludes weekends or includes only working days.

With respect to your comments #2, #3 and #4 you are hereby authorized to use Form AEC-284 in lieu of filing a copy of Form AEC-741, required by 10 CFR 70.54, to acknowledge receipt of special nuclear material where receipt measurements are delayed. Receipt measurements must be completed and reported on Form AEC-741 within 30 days of the receipt of the material except in the case of shipments of scrap and irradiated material.

C/25A

ITEM # 255

(6) I

Westinghouse Electric -2-
Corporation

APR 26 1972

The requirement that Form AEC-741 be dispatched the day the material is shipped was initiated for two reasons: (1) to provide receiver's of material with timely notifications of special nuclear material shipped; and (2) to permit the AEC's Nuclear Materials Information System to reflect timely data on nuclear materials transactions.

If you have any further questions on this matter, please let me know.

Sincerely,

C. D. W. Thornton, Director
Division of Nuclear Materials Safeguards

DISTRIBUTION

PDR, w/incoming
Docket 70-337, w/incoming
CKBeck, DR, w/incoming
LDLow, CO, w/o incoming
CO:I, w/incoming
SSmiley, DML, w/incoming
DLCrowson, NUMS, w/incoming
GC, w/o incoming
SO-I, w/incoming
NMS Case File, w/incoming
DR Reading, w/o incoming
NMS Reading, w/o incoming
VJD Reading, w/o incoming

| | | | | | | |
|-----------|---------------|----------|-------------|---------|--|--|
| OFFICE ▶ | NMS | NMS | NMS | NMS | | |
| SURNAME ▶ | FJMiraglia:kb | VJQArico | CDWThornton | JFB/RGR | | |
| DATE ▶ | 4/19/72 | 4/19/72 | 4/24/72 | | | |

Westinghouse Electric Corporation

Power Systems

Box 355
Pittsburgh Pennsylvania 15230
March 17, 1972

LOCKET NO. 70-337

U. S. Atomic Energy Commission
Division of Nuclear Materials Safeguards
Washington, D. C. 20545

Attention: Dr. C. D. W. Thornton, Director

Subject: Your Letter NMS:JVC/70-337, Dated February 28, 1972

The Westinghouse Electric Corporation provides the following comments in response to the subject letter:

1. Westinghouse recognizes the desirability of disseminating information promptly. We conscientiously endeavor to function within the time periods imposed by the USAEC. We review our operating procedures at intervals and continuously review our performance in an effort to improve our reporting system. Obviously, a combination of random circumstances may enter into whether the required data for a specific receipt can be completely and accurately determined and transmitted within the "specified" time period. Some of these factors are the material source, the chemical and physical form of the material, the types of analyses required, the availability of analytical facilities, urgent production schedular demands, any lag between the Federal postal system and freight deliveries, the occurrence of a second intervening weekend, and scheduled holidays and shutdowns.

We have reviewed the transfer series (ZQN-ZYP) noted by your inspector during the safeguards audit summary meeting and we offer the following analysis of our performance.

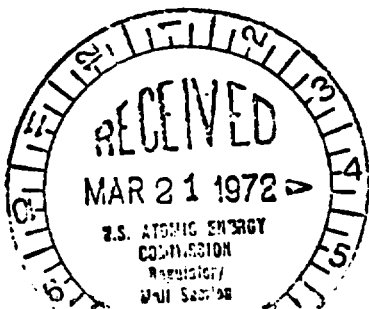

1. (continued)

Over the period of November, 1970 through October 16, 1971, a total of 116 transactions were reported. Of this number, two were multiple corrections, resulting in a working number of 114 separate documents. Of this number, 39 were nominally processed after the tenth calendar day following the date of receipt of the material. When the provisions of 10CFR2.710 are applied to the allowed period, the number of documents in question decreases to 28. If the ten calendar days are interpreted to include only a single week-end, the allowed time period can be expressed as eight working days. The number of documents requiring more than eight working days decreases to 17. Of these 17 items, 8 required 9 working days, 2 required 10, 4 took 11, and 3 required the maximum of 12 working days.

The timing of these various instances is also significant. The worst instances of delay occurred early in 1971, during the early months of the period subject to inspection. By March, our internal performance review had detected the situation and corrective action was instituted. During the part of the inspection period starting with the first of May, only 6 instances of technically overdue documents occurred, and of these only 3 violated the eight-working-day interpretation (2 by 1 working day, the other by 2). This demonstrated marked improvement over the second half of the period under review.

In the period since the safeguards inspection, only two documents required more than ten calendar days. In both instances the time period was nominally eleven days, but these eleven calendar days included two Saturdays, two Sundays and a two-day Thanksgiving holiday! Therefore, the data were actually processed in just five working days.

2. Our fundamental material controls - as well as deep concerns expressed by Dr. Thornton (such as in his letters of May 6, 1971 and December 23, 1971) - require precise, positive measurements on all incoming SNM and the inclusion on Form AEC-741 of this measured data and their supporting limits of error.

2. (continued)

Westinghouse is aware of the provisions, contained in the instructions, for using an incomplete Form AEC-741 as a notification of receipt when all specified data is not readily available. Unfortunately, using the Form in this manner imposes a requirement for processing subsequent documents describing the same material transfer.

The use of Form AEC-741 was originally instituted to simplify the transfer of the applicable data to electronic data processing (EDP) equipment. The use of EDP systems within the industry is increasing, but no standard method of handling "incomplete" forms has been adopted. In fact, there appears to be as many ways of processing data as there are shippers and receivers. Therefore, attempts to use incomplete Form AEC-741's, as described in the instructions, run the risk of creating confusion when corrective documents designed for one system must be processed by EDP programmed for another system.

3. Westinghouse would like to point out that, based on our considerable experience in handling SNM held under USAEC contracts, we are convinced that Form AEC-284 effectively fulfills a useful function in the elaborate documentation associated with the transfer of SNM. If licensees could use a separate document for transfers when only preliminary or incomplete information is available, it would facilitate EDP processing by reserving Form AEC-741 for the transmittal of complete and accurate data, as the form was intended. This would contribute to effective data transmission and would reduce the confusion and possible errors resulting from processing multiple transmittals dealing with a single transaction and transfer series.

The Westinghouse Electric Corporation requests that the Commission institute a proceeding to study the desirability of adopting some type of preliminary shipping/receiving notification form plus the associated relaxation of the time limitations now specified for Form AEC-741. This proceeding might also appropriately consider the propriety of implementing a system of graded safeguards.

4. With respect to the subject notice, Westinghouse requests concurrence that notification of receipt and preliminary data may continue to be transmitted informally when required, and that Form AEC-741 be reserved for final data transmission without a specific time limitation. This position is dictated by considerations of increased safeguards program effectiveness plus reduced possibility for confusion or error in data processing. The observance of an arbitrary deadline that is unrelated to any concrete need appears to provide no meaningful contribution to effective nuclear materials safeguards.

Westinghouse considers it appropriate to use this letter to discuss a closely related subject. A letter dated October 5, 1971, signed by Dr. Thornton, revised the instructions for using Form AEC-741 to require that reports (Form AEC-741) by the SNM shipper be dispatched to the receiver on the same day the material is shipped. Westinghouse would like to iterate the industry position that for any licensee large enough to be subject to safeguards, the "Same day" requirement simply is not realistic. Furthermore, if faced with the necessity to make a choice, Westinghouse would prefer to choose to provide complete and accurate data of value to safeguards, rather than technical compliance for the sake of an arbitrary deadline.

However, here again the use of a separate, special form could provide a mechanism for essential notification and gross data transmission functions, in a timely manner. The use of such a form would permit Form AEC-741 to be reserved for the specific use for which it was designed, - the eventual transmittal of complete and accurate data. As previously stated, such a proper application of the Form could made a definite contribution to consistent accuracy and clarity in EDP processing of safeguards data and contribute to a meaningful safeguards program for the parties concerned.

Further communications on this matter should continue to be directed to me at the above address.

Very truly yours,



Karl R. Schendel
License Administrator

KRS:jh

NMS:RDS
70-337
70-1143
70-1151

JUN 15 1970

DISTRIBUTION w/encl:
Public Doc. Room
Docket File
OGC
LDLow, CO (2)
DANussbaumer, DML
OSMM/Crowson
SO-I
VJD'Amico (2)
RGPPage
RDSmith
NMS Reading w/o encl.
DR Reading w/o enc.
L&R Case File

W. B. ...

Hep

Westinghouse Electric Corporation
Gateway Center
Box 2273
Pittsburgh, Pennsylvania 15230

Attention: Mr. Karl R. Schendel
License Administrator

Gentlemen:

In accordance with our letter dated April 24, 1970, and your reply dated May 22, 1970, Special Nuclear Material License No. SNM-333 is hereby amended to incorporate Safeguards Amendment No. SG-2, superseding Amendment SG-1; Special Nuclear Material License No. SNM-1120 is hereby amended to incorporate Safeguards Amendment No. SG-3, superseding Amendment SG-2; and Special Nuclear Material License No. SNM-1107 is hereby amended to incorporate Safeguards Amendment No. SG-3, superseding Amendment SG-2. These amendments supersede in their entirety those amendments which were previously issued to the licenses.

With respect to your comment concerning License Conditions 3.4, 3.5 and 6.3, adjustment of book inventories and reports of MUF exceeding the limits of error are to be made after completion of the annual physical inventory required by Condition 6.1. New Condition 7.3 requires you to file a monthly report of all intentional discards and notwithstanding the associated limits of error. The actions taken following the report will depend upon the result of your investigation.

FOR THE ATOMIC ENERGY COMMISSION

Original Signed by
Ralph G. Page

Ralph G. Page, Acting Director
Division of Nuclear Materials
Safeguards

I *CP255* *(P)*

Enclosures:
Amendments (3)

| | | | |
|-----------|------------------------|-------------|--------------|
| cc: | DR. Frederick Forscher | NMS | NMS:ACT DIR. |
| OFFICE ▶ | | RDSmith:lrn | RGP |
| SURNAME ▶ | | | 6/15 |
| DATE ▶ | | 6-12-70 | |

ITEM # 256

COPY

UNITED STATES
ATOMIC ENERGY COMMISSION

LICENSE AMENDMENT
FOR
SPECIAL NUCLEAR MATERIALS SAFEGUARDS

Pursuant to the Atomic Energy Act of 1954, as amended, and Title 10, Code of Federal Regulations, Chapter 1, Part 70, the following amendment to the special nuclear material license identified below is hereby issued, incorporating controls for the safeguarding of special nuclear material.

Licensee

Name: Westinghouse Electric
Corporation

License No. SNM-338

Address: 3 Gateway Center, Box 2278
Pittsburgh, Pennsylvania
15230

Amendment No. SG-2

Docket No. 70-337

CONDITIONS

1.0 FACILITY ORGANIZATION

1.1 For each designated organization, the following management position(s) shall be responsible for and carry out the duties assigned herein to the Safeguards Manager and those assigned to the Safeguards Representative:

1.1.1 Manufacturing Department, Nuclear Fuel Division (NFD) - the Manager, Manufacturing Department, NFD, shall be the Safeguards Manager and the Manager, Nuclear Materials Safeguards, Manufacturing Department, NFD, shall be the Safeguards Representative.

1.1.2 Material Systems Laboratory (MSL), Nuclear Fuel Division - The Manager, MSL, shall be the Safeguards Manager and the MSL License Administrator shall be the Safeguards Representative.

COPY

- 1.1.3 Plutonium Laboratory, Advanced Reactor Division (ARD) -
The Manager, Cheswick Fuel Facility, ARD, shall be the
Safeguards Manager as well as the Safeguards Representative.
- 1.2 The Safeguards Manager shall have the responsibility for implement-
ing and enforcing the nuclear material control procedures and
managing an overall system of nuclear control. The Safeguards
Representative shall have the responsibility for developing,
revising and auditing the nuclear material control procedures.
- 1.3 Nuclear material control procedures and revisions thereto shall
be approved by the Safeguards Manager. A manual containing all
current nuclear material control procedures shall be maintained
by the Safeguards Representative.
- 1.4 The Safeguards Representative shall assure that the nuclear
material control procedures are appropriately reflected in
manufacturing instructions, standard operating procedures, or
similar detailed management instructions.
- 1.5 All delegations of safeguards responsibilities by the Safeguards
Manager shall be in writing.
- 2.0 FACILITY OPERATION
- 2.1 Material Balance Areas (MBA's) shall be established by the Safe-
guards Representative.
- 2.2 Each MBA shall be an identifiable physical area into and out of
which movement of special nuclear material can be measured.
- 2.3 Sufficient numbers of MBA's shall be established so that losses
of special nuclear material can be identified and localized.
- 2.4 All operations within an MBA shall be the responsibility of a
single employee who shall also be responsible for the custody of
special nuclear material within his MBA.

3.0 MEASUREMENTS AND STATISTICAL CONTROLS

- 3.1 The licensee shall determine the U-235, U-233, and/or Pu content of all receipts, shipments, intentional discards and material inventoried, along with the limits of error associated with these quantities. The licensee shall make sufficient measurements to substantiate the stated quantities and associated limits of error. Measurements are not required on items which have been determined by other means to contain less than ten (10) grams U-235, U-233, and/or Pu each. Limits of error as used herein means the boundaries within which the true or best value of the parameter being measured lies with a probability of 95%.
- 3.2 A program of standardization and calibration of measurement equipment and analytical procedures shall be maintained to provide data to substantiate the limits of error associated with all measurements required for safeguards purposes.
- 3.3 All measurements required by this amendment shall be reviewed annually by the Manager of Quality Control, Cheswick Plant Operations, Manufacturing Department, NFD. This review shall include a quantitative calculation of limits of error of the measurement system. The Manager of Quality Control, Cheswick Plant Operations, Manufacturing Department, NFD, or Manager of Quality Assurance, Manufacturing Department, NFD, shall utilize data obtained through calibrations specified in Condition 3.2 to monitor performance of the measurement system to assure calculated limits of error are maintained between reviews. Records of reviews, calculations, and use of calibration data shall be kept by the Quality Assurance Department, Manufacturing Department, NFD, or the Quality Control Department, Cheswick Plant Operations, Manufacturing Department, NFD.
- 3.4 After any physical inventory the material unaccounted for (MUF) and the limits of error associated with the material unaccounted for shall be computed promptly. The limits of error associated with

MUF shall be calculated by statistically combining the limits of error determined for shipments, receipts, beginning inventory, ending inventory, and measured losses for the period since the last inventory.

- 3.5 If the quantity of MUF exceeds the associated limits of error, the licensee shall promptly notify the Atomic Energy Commission, Division of Nuclear Materials Safeguards, District I Office, Newark, New Jersey. The licensee shall investigate the MUF and notify the Division of Nuclear Materials Safeguards within thirty (30) days after the initial notice, specifying the probable reasons for the MUF and the corrective action taken or planned.

4.0 SHIPPING AND RECEIVING

- 4.1 All shipper-receiver differences shall be brought to the attention of the Safeguards Representative, who shall evaluate these differences to determine whether they are statistically significant and of sufficient magnitude to warrant investigation. The Safeguards Representative shall investigate all statistically significant differences which exceed \$500 value. A shipper-receiver difference shall be considered statistically significant when (1) the difference exceeds the statistical combination of the limits of error of the shipper's and receiver's measurements, or (2) if the shipper's limits of error is unknown, the difference exceeds twice the limits of error for the receiver's measurement. Statistical analysis of past performance, measurement uncertainties, and other data shall be kept.

5.0 STORAGE AND INTERNAL TRANSFERS

- 5.1 A documented system of control over special nuclear material stored and processed within the facility shall be maintained which will provide continuous knowledge of the location, and quantity of all material contained in discrete, identifiable items or containers.

- 5.2 All transfers of special nuclear material between MBA's shall be documented to show the identity, quantity, and isotopic analysis of the material transferred. A system of controls shall be maintained by the licensee for the distribution and accounting of all transfer documents.
- 5.3 Each document supporting a transfer of material between MBA's shall be signed by the delegated individual.
- 6.0 INVENTORY
 - 6.1 A complete physical inventory of all special nuclear material subject to this license shall be conducted at approximately twelve-month intervals, but in no case shall more than fourteen months elapse between inventories.
 - 6.2 Prior to each complete physical inventory, written procedures shall be prepared which:
 - 6.2.1 specify the extent to which each MBA is to shut down and clean out process equipment;
 - 6.2.2 specify the extent to which each MBA is to remain static during the inventory;
 - 6.2.3 identify the basis for accepting for inventory purposes previously made measurements and their limits of error;
 - 6.2.4 designate measurements to be made for inventory purposes to establish and demonstrate the limits of error associated with the quantity of material on inventory; and
 - 6.2.5 identify the manner by which material on inventory will be listed to assure each item is inventoried and there are no duplications or omissions.
 - 6.3 The book inventory shall be reconciled with and adjusted to the results of the physical inventory upon completion of the physical inventory.

6.4 Special physical inventories of an MBA shall be conducted whenever there is reason to believe that subsequent to the last prior physical inventory a particular MBA has experienced losses or gains that are different by a statistically significant amount from those expected.

7.0 RECORDS AND REPORTS

7.1 The licensee shall establish and maintain a records system which will provide sufficient information to maintain a material balance around each MBA and the total plant. These records shall contain information pertaining to all receipts, shipments, measured discards, inventory, and MUF for each material balance. MBA and central ledger records shall be reconciled at the end of each accounting period. All entries in the records shall be supported by appropriate documents.

7.2 All measured discards and MUF shall be reported on a monthly basis by the Safeguards Representative to the Safeguards Manager and to senior licensee management.

7.3 The licensee shall report on a monthly basis all intentional discards and material unaccounted for. The MUF shall be that which has been determined during the month as a result of completing a material balance around a single operation, a number of operations, or the entire plant. This report shall be made within fifteen (15) days after the end of the month in which the discard was made or the material unaccounted for was determined. Reports shall be sent to the U.S. Atomic Energy Commission, Division of Nuclear Materials Safeguards, District I, Newark, New Jersey. Each report shall be identified by the Reporting Identification Symbol(s) (RIS) assigned to the licensed operations and shall include a statement of the nature of the discards, the probable reasons for the MUF and any actions taken or planned with respect to the MUF.

8.0 MANAGEMENT OF MATERIALS CONTROL SYSTEM

8.1 At least once each year the licensee shall conduct, independent of the Safeguards Representative, an internal review of the nuclear materials control procedures and management of the overall system of special nuclear material control, and report the findings to senior management.

COPY

License No. SNM-338

Page 7 of 7 pages

Amendment No. SG-2

Docket No. 70-337

- 8.2 An estimate of anticipated losses (measured discards plus MUF) for each period of time between inventories shall be prepared for each MBA, with the concurrence of the Safeguards Representative, and shall be based on prior experience, throughput quantities and rates, etc. If losses exceed the estimate of those anticipated, they shall be investigated by the Safeguards Representative and the results of his investigation shall be reported to the Safeguards Manager.
- 8.3 Any apparent loss of a discrete item or container of special nuclear material which cannot be resolved by an immediate investigation shall be reported to the Safeguards Representative who shall promptly notify the Atomic Energy Commission, Division of Nuclear Materials Safeguards, District I Office, Newark, New Jersey, and shall conduct an investigation of the loss. The Safeguards Representative shall report the results of his investigation to the senior licensee management.

FOR THE ATOMIC ENERGY COMMISSION

Date of Amendment JUN 15 1970

Original Signed by
Ralph G. Page

Division of Nuclear Materials
Safeguards

COPY

OFFICIAL USE ONLY

UNITED STATES ATOMIC ENERGY COMMISSION
OFFICE OF DIRECTOR OF REGULATION
DIVISION OF NUCLEAR MATERIALS SAFEGUARDS

report of the
INSPECTION OF SAFEGUARDS
CONTROL OF NUCLEAR MATERIALS
of

RIS:

License No.: SNM-338

Docket No.: 70-337

Westinghouse Electric Corporation
(Section I)

Inspection No.: SO-I-18

Inspection Date: 10/29 - 11/7/69

Report Date: January 8, 1970

For the period: 11/1/68

To: 10/31/69

OFFICIAL USE ONLY

C/257

(5)

ITEM # 257

CONFIDENTIAL ONLY

Section I
Inspection of Safeguards Activities
at Westinghouse Electric Corporation
Cheswick, Pennsylvania
License No. SNM-338 Docket No. 70-337
SO-I-18

I.

A. INTRODUCTION

An inspection of safeguards control over special nuclear material at Westinghouse Electric Corporation was performed during the period October 29 through November 7, 1969. The inspection covered the period November 1, 1968 through October 31, 1969. Under AEC License No. 338, the licensee maintains four distinct material balance areas as follows:

(1) MBA-3-Analytical Laboratory

The MBA gives analytical support to fuel manufacturing and development laboratory. Incoming shipments of UO_2 powder manufactured pellets and generated scrap are assayed for Uranium, Uranium-235 content and impurities.

(2) MBA-4-Fuel Manufacturing

Pellets are fabricated from low enriched uranium oxide and are inserted into tubes to form rods. The rods are then assembled into elements for use in power reactors. To date the facility does not have the capability to convert UF_6 to UO_2 or reclaim uranium from scrap. These services are obtained through contracts with other licensees.

(3) MBA-5-Development Laboratory

This area develops and tests new techniques of fuel fabrication for possible use by fuel manufacturing on a pilot plant scale, the capabilities at the development laboratory are similar to those at fuel manufacturing.

(4) MBA-6-Plutonium Laboratory

At this MBA, techniques to manufacture reactor fuel rods containing ceramic plutonium pellets are developed and tested. Uranium, plutonium, oxide and carbide mixtures have been studied during the inspection period.

B. SCOPE OF INSPECTION

- (1) The inspection was made to determine the licensee's conformance to the safeguards requirements contained in Title 10, CFR, Part 70,
- CONFIDENTIAL ONLY

"Special Nuclear Material," Part 73, "Physical Protection of Special Nuclear Material in Transit," and the specific safeguards requirements contained in License No. SNM-338 Amendment SG-1.

- (2) The licensee's safeguards controls were reviewed in accordance with guidelines in the Handbook for Inspection of Class I Licensee, Operations Manual Appendix 1005A.

C. CATEGORIZATION

Each material balance area was categorized and sampled as follows:

MBA 3,4

| <u>Category</u> | <u>Description</u> | <u>No. of Line Items</u> | <u>Gms Pu</u> | <u>Gms U-235</u> | <u>No. of Samples</u> |
|-----------------|----------------------------------|------------------------------|---------------|------------------|---------------------------|
| I | UO ₂ feed power press | 287 | — | 283,506 | 32 |
| I | Sintered pellets | 106 | — | 579,750 | 32 |
| III | Sludges, scrap pellets | 326 | — | 98,852 | 32 |
| V | Fuel rods | 109 | — | 1,177,726 | 32 |
| V | Fuel assemblies | 152 | — | 1,658,109 | — |
| | Items not sampled | 75 | — | 449 | — |
| | | | | <u>3,798,392</u> | <u>128</u> |

The UO₂ powder, press feed and green pellet sample items were checkweighed, sampled, and samples forwarded to New Brunswick Laboratory for assay. The count of thirty-two trays of pellets was checked to determine whether the practice of 900 pellets per tray was maintained. Ten pellets from each of following jobs: CPAF-III, WEAf-I, NOBF and KEAF-III were gamma counted and one pellet from each of the jobs checked forwarded to New Brunswick Laboratory for assay to serve as counting standards. Items in Category III were checkweighed, sampled and all samples forwarded to New Brunswick Laboratory for assay. The piece count of thirty-two bins of fuel rods were verified. Thirty-two fuel rods in job CPAF-II were gamma counted, and a weighed rod made up in the presence of the inspection team was used as a standard. Six pellets were taken during the loading of the standard rod and forwarded to NBL for assay.

MBA-5

| <u>Category</u> | <u>Description</u> | <u>No. of Line Items</u> | <u>Gms Pu</u> | <u>Gms U-235</u> | <u>No. of Samples</u> |
|-----------------|--|------------------------------|---------------|------------------|---------------------------|
| I | UO ₂ pellets | 106 | — | 15,041 | 30 |
| I | UO ₂ , U ₃ O ₈ , UC | 35 | — | 5,656 | 27 |
| V | Fuel Rods | 204 | 1,260 | 6,895 | 30 |
| | Items not sampled | 44 | — | 3,993 | — |
| | | <u>389</u> | <u>1,260</u> | <u>31,585</u> | <u>87</u> |

The thirty UO₂ pellets samples were gamma counted and eight pellets forwarded to New Brunswick Laboratory for assay to serve as counting standards. The twenty-seven powder items were checkweighed, sampled and the samples forwarded to New Brunswick Laboratory for assay. Thirty fuel rods were checkweighed and the manufacturing data checked to verify the U-235 content of each rod.

MBA-6

| <u>Category</u> | <u>Description</u> | <u>No. of Line Items</u> | <u>Gms Pu</u> | <u>Gms U-235</u> | <u>No. of Samples</u> |
|-----------------|--------------------|------------------------------|---------------|------------------|---------------------------|
| III | Scrap | 103 | 3,837 | 5,185 | 35 |
| V | Fuel rods | 87 | 646 | 1,555 | 32 |
| | Items not sampled | 31 | 186 | 212 | — |
| | | <u>221</u> | <u>4,669</u> | <u>6,952</u> | <u>67</u> |
| | Totals(all MBAS) | <u>1,665</u> | <u>5,929</u> | <u>3,836,929</u> | <u>282</u> |

Sample items in Category III were checkweighed, sampled, and samples forwarded to the New Brunswick Laboratory for assay. Items in Category V were checked by a review of production data.

D. SUMMARY OF FINDINGS

1. There were no exceptions noted in regard to the licensee's compliance with safeguards requirements of amendment SG-1 of SNM-338, 10 CFR Parts 70 and 73.
2. Measured discards and MUF (all values in grams)

MBA 3,4

| | <u>U</u> | <u>U-235</u> | <u>U-235% of Thruput</u> |
|---|-------------|--------------|------------------------------|
| Measured discards for inspection period | 68,800 | 2,083 | .023 |
| MUF up to physical inventory | 838,400 | 24,199 | .271 |
| MUF as result of physical inventory | (85,373) | (1,132) | .013 |
| Throughput for period (beg, inv. plus rec.) | 310,846,988 | 8,929,526 | |

MBA-5

| | <u>U</u> | <u>U-235</u> | <u>U-235% Thruput</u> | <u>Pu</u> |
|----------------------------------|----------|--------------|---------------------------|-----------|
| Measured discards for insp. per. | 236 | 29 | .007 | — |
| MUF up to physical inventory | 59 | 5 | — | — |
| MUF as result of phy. inventory | 486 | 165 | .042 | — |
| Throughput for period | 517,090 | 39,741 | | 1,355 |

MBA-6

| | <u>U</u> | <u>U-235</u> | <u>U-235 % Thruput</u> | <u>Pu of % Thruput</u> |
|---------------------------------|----------|--------------|----------------------------|----------------------------|
| Measured losses for insp. per. | 137 | 128 | .109 | 108 2.102 |
| MUF up to phy. inventory | (2) | (1) | — | 38 .740 |
| MUF as result of phy. inventory | 100 | 84 | .072 | 134 2.608 |
| Throughput for period | 13,681 | 11,696 | | 5,138 |

OFFICIAL USE ONLY

3. Shipper Receiver differences

Total receipts for the inspection period were

| | <u>U kg</u> | <u>U-235 kg</u> | <u>Pu kg</u> |
|---------|-------------|-----------------|--------------|
| MBA 3,4 | 204,749 | 5,802 | — |
| MBA 5 | 22 | 1 | — |
| MBA 6 | 4 | 2 | 3 |

The licensee accepted all receipts as stated by the shipper, however, limits of errors were not observed for the shipper's and receiver's values of individual shipments.

Total shipments for the period which had receiver measurements were:

| <u>Total Licensee</u> | | <u>Total Receiver</u> | | <u>% Differences</u> | |
|-----------------------|-----------------|-----------------------|-----------------|----------------------|--------------|
| <u>U kg</u> | <u>U-235 kg</u> | <u>U kg</u> | <u>U-235 kg</u> | <u>U</u> | <u>U-235</u> |
| 45,978 | 1,586 | 45,959 | 1,586 | 0.04 | — |

The licensee accepted all values reported by the receiver, adjustments to the accountability records were taken to reflect the receivers measurements. Limits of errors were not observed for the shipper's and receiver's values for individual shipments.

4. Program Weaknesses

- (a) The licensee is urged to attempt to keep material held up in processing equipment at MBA-4 to a minimum during the taking of the annual inventory. The U-235 estimated as held up in equipment was approximately 1 kilogram; this quantity appears reasonable and would not have distorted the determined quantity of MUF if this quantity was identified as MUF. However, since this estimate is subject to a large error (100-200%), appreciable estimates could distort the true MUF and possible require re-inventory by the licensee.
- (b) The licensee failed to properly identify adjustments taken to MBA-4 accountability records which reflected shipper-receiver differences. These adjustments appeared as measured discards in lieu of MUF.

DATE OF REPORT: January 8, 1970

APPROVED: Ira Cohen
Ira Cohen, Team Leader

OFFICIAL USE ONLY

Walter G. Martin
Walter G. Martin, Director
District I Safeguards Office

FILE
6/18/69
hp

JUN 20 1969

NMS:FJM
70-337

Westinghouse Electric Corporation
3 Gateway Center
Box 2278
Pittsburgh, Pennsylvania 15230

Attention: Mr. K. R. Schendel
License Administrator

Gentlemen:

As discussed with you on June 11, 1969, I am enclosing a copy of the safeguards amendment that we are planning to issue to your special nuclear material license SNM-338, on or about June 30, 1969. The license conditions in this amendment are based on our review of your June 6, 1969, submittal of proposed fundamental material controls.

It is requested that you provide us with a revised description of your safeguards procedures which support the license conditions within thirty (30) days after the amendment is issued.

Please inform us of any comments that you might have on the proposed amendment by June 25, 1969.

Sincerely,

Original Signed by
Vincent J. D'Amico

R. P. Wischow, Director
Division of Nuclear Materials
Safeguards

ITEM # 258

Enclosure:
Proposed Safeguards Amendment

DISTRIBUTION:

NMS File
NMS Reading File
DR Reading File
F. J. M. (initials)

OGC →
RGPage
Pub. Doc. Room

LDLow, CO
JAMcBride, DML
OSMM/Crowson

WMartin, SO-I
DNussbaumer, DML
VJD'Amico (2)

CP258

⑧

| | | | | | | |
|-----------|-------------------------|----------------------|-----|--|--|-------------|
| OFFICE ▶ | NMS: FJM: [initials] | NMS:DIR RPWischow | OGC | | | |
| SURNAME ▶ | [initials] | [initials] | | | | JUN 24 1969 |
| DATE ▶ | 6-18-69 | | | | | |

UNITED STATES
ATOMIC ENERGY COMMISSION

LICENSE AMENDMENT
FOR
SPECIAL NUCLEAR MATERIALS SAFEGUARDS

Pursuant to the Atomic Energy Act of 1954, as amended, and Title 10, Code of Federal Regulations, Chapter 1, Part 70, the following amendment to the special nuclear material license identified below is hereby issued, incorporating controls for the safeguarding of special nuclear material.

Licensee

| | |
|--|---------------------|
| Name: Westinghouse Electric Corporation | License No. SNM-338 |
| Address: 3 Gateway Center, Box 2278 Pittsburgh, Pennsylvania 15230 | Amendment No. SG-1 |
| | Docket No. 70-337 |

CONDITIONS

1.0 FACILITY ORGANIZATION

1.1 For each designated organization, the following management position(s) shall be responsible for and carry out the duties assigned herein to the Safeguards Manager and those assigned to the Safeguards Representative:

- 1.1.1 Manufacturing Department, Nuclear Fuel Division (NFD) -
The Manager, Cheswick Plant Operations, shall be the Safeguards Manager and the Manager, Nuclear Materials Safeguards, shall be the Safeguards Representative.
- 1.1.2 Material Systems Laboratory (MSL), Nuclear Fuel Division -
The Manager, MSL, shall be the Safeguards Manager and the MSL License Administrator shall be the Safeguards Representative.

License No. SNM-338

Amendment No. SG-1

Docket No. 70-337

- 1.1.3 Plutonium Laboratory, Advanced Reactor Division (ARD) -
The Manager, Cheswick Fuel Facility, ARD, shall be the
Safeguards Manager as well as the Safeguards Representative.
- 1.2 The Safeguards Manager shall have the responsibility for implement-
ing and enforcing the nuclear material control procedures and
managing an overall system of nuclear control. The Safeguards
Representative shall have the responsibility for developing, revis-
ing and auditing the nuclear material control procedures.
- 1.3 Nuclear material control procedures and revisions thereto shall be
approved by the Safeguards Manager. A manual containing all current
nuclear material control procedures shall be maintained by the
Safeguards Representative.
- 1.4 The Safeguards Representative shall assure that the nuclear material
control procedures are appropriately reflected in process specifica-
tions, manufacturing instructions, standard operating procedures,
or similar detailed management instructions.
- 1.5 All delegations of safeguards responsibilities by the Safeguards
Manager shall be in writing.
- 2.0 FACILITY OPERATION
- 2.1 Material Balance Areas (MBA's) shall be established by the Safe-
guards Representative.
- 2.2 Each MBA shall be an identifiable physical area into and out of
which movement of special nuclear material can be measured.
- 2.3 Sufficient numbers of MBA's shall be established so that losses
of special nuclear material can be identified and localized.
- 2.4 All operations within an MBA shall be the responsibility of a
single employee who shall also be responsible for the custody of
special nuclear material within his MBA.

3.0 MEASUREMENTS AND STATISTICAL CONTROLS

- 3.1 The licensee shall determine the U-235 and/or Pu content of all receipts, shipments and measured discards. The U-235 and/or Pu content shall also be determined for all material inventoried. The limits of error* associated with these quantities shall be determined. Sufficient measurements shall be made to substantiate the stated quantities and associated limits of error.
- 3.2 A program of standardization and calibration of measurement equipment and analytical procedures shall be maintained to provide data to substantiate the limits of error associated with all measurements required for safeguards purposes.
- 3.3 All measurements required by this amendment shall be reviewed annually by the Manager of Quality Control, Cheswick Plant Operations, Manufacturing Department, NFD, or the Manager of Quality Assurance, Manufacturing Department, NFD. This review shall include a quantitative calculation of limits of error of the measurement system. The Manager of Quality Control, Cheswick Plant Operations, Manufacturing Department, NFD, or the Manager of Quality Assurance, Manufacturing Department, NFD, shall utilize data obtained through calibrations specified in Condition 3.2 to monitor performance of the measurement system to assure calculated limits of error are maintained between reviews. Records of reviews, calculations, and use of calibration data shall be kept by the Quality Assurance Department, Manufacturing Department, NFD, or the Quality Control Department, Cheswick Plant Operations, Manufacturing Department, NFD.
- 3.4 After any physical inventory the material unaccounted for (MUF) and the limits of error associated with the material unaccounted for shall be computed promptly. The limits of error associated with

* Limits of error as used herein means the boundaries within which the true (best) value of the parameter being measured lies with a probability of 95%.

License No. SNM-338

Page 4 of 7 pages

Amendment No. SG-1

Docket No. 70-337

MUF shall be calculated by statistically combining the limits of error determined for shipments, receipts, beginning inventory, ending inventory, and measured losses for the period since the last inventory.

- 3.5 If the quantity of MUF exceeds the associated limits of error, the licensee shall promptly notify the Atomic Energy Commission, Division of Nuclear Materials Safeguards, District I Office, Newark, New Jersey. The licensee shall investigate the MUF and notify the Division of Nuclear Materials Safeguards within thirty (30) days after the initial notice, specifying the probable reasons for the MUF and the corrective action taken or planned.

4.0 SHIPPING AND RECEIVING

- 4.1 All shipper-receiver differences shall be brought to the attention of the Safeguards Representative, who shall evaluate these differences to determine whether they are statistically significant and of sufficient magnitude to warrant investigation. The Safeguards Representative shall investigate all statistically significant differences which exceed \$500 value. A shipper-receiver difference shall be considered statistically significant when (1) the difference exceeds the statistical combination of the limits of error of the shipper's and receiver's measurements, or (2) if the shipper's limits of error is unknown, the difference exceeds twice the limits of error for the receiver's measurement. Statistical analyses of past performance, measurement uncertainties, and other data shall be kept.

5.0 STORAGE AND INTERNAL TRANSFERS

- 5.1 A documented system of control over special nuclear material stored and processed within the facility shall be maintained which will provide continuous knowledge of the location, and quantity of all material contained in discrete, identifiable items or containers.

- 5.2 All transfers of special nuclear material between MBA's shall be documented to show the identity, quantity, and isotopic analysis of the material transferred. A system of controls shall be maintained by the licensee for the distribution and accounting of all transfer documents.
- 5.3 Each document supporting a transfer of material between MBA's shall be signed by the delegated individual.
- 6.0 INVENTORY
- 6.1 A complete physical inventory of all special nuclear material subject to this license shall be conducted at approximately twelve-month intervals, but in no case shall more than fourteen months elapse between inventories.
- 6.2 Prior to each complete physical inventory, written procedures shall be prepared which:
- 6.2.1 specify the extent to which each MBA is to shut down and clean out process equipment;
 - 6.2.2 specify the extent to which each MBA is to remain static during the inventory;
 - 6.2.3 identify the basis for accepting for inventory purposes previously made measurements and their limits of error;
 - 6.2.4 designate measurements to be made for inventory purposes to establish and demonstrate the limits of error associated with the quantity of material on inventory; and
 - 6.2.5 identify the manner by which material on inventory will be listed to assure each item is inventoried and there are no duplications or omissions.
- 6.3 The book inventory shall be reconciled with and adjusted to the results of the physical inventory upon completion of the physical inventory.

License No. SNM-338

Amendment No. SG-1

Docket No. 70-337

6.4 Special physical inventories of an MBA shall be conducted whenever there is reason to believe that subsequent to the last prior physical inventory a particular MBA has experienced losses or gains that are different by a statistically significant amount from those expected.

7.0 RECORDS AND REPORTS

7.1 The licensee shall establish and maintain a records system which will provide sufficient information to maintain a material balance around each MBA and the total plant. These records shall contain information pertaining to all receipts, shipments, measured discards, inventory, and MUF for each material balance. MBA and central ledger records shall be reconciled at the end of each accounting period. All entries in the records shall be supported by appropriate documents.

7.2 All measured discards and MUF shall be reported on a monthly basis by the Safeguards Representative to the Safeguards Manager and to senior licensee management.

8.0 MANAGEMENT OF MATERIALS CONTROL SYSTEM

8.1 At least once each year the licensee shall conduct, independent of the Safeguards Representative, an internal review of the nuclear materials control procedures and management of the overall system of special nuclear material control, and report the findings to senior management.

8.2 An estimate of anticipated losses (measured discards plus MUF) for each period of time between inventories shall be prepared for each MBA, with the concurrence of the Safeguards Representative, and shall be based on prior experience, throughput quantities and rates, etc. If losses exceed the estimate of those anticipated, they shall be investigated by the Safeguards Representative and the results of his investigation shall be reported to the Safeguards Manager.

License No. SNM-338

Page 7 of 7 pages

Amendment No. SG-1

Docket No. 70-337

- 8.3 Any apparent loss of a discrete item or container of special nuclear material which cannot be resolved by an immediate investigation shall be reported to the Safeguards Manager, who shall promptly notify the Atomic Energy Commission, Division of Nuclear Materials Safeguards, District I Office, Newark, New Jersey, and shall conduct an investigation of the loss. The Safeguards Manager shall report the results of his investigation to the senior licensee management.

FOR THE ATOMIC ENERGY COMMISSION

Date of Amendment _____

Division of Nuclear Materials
Safeguards

UNITED STATES
ATOMIC ENERGY COMMISSION

LICENSE AMENDMENT
FOR
SPECIAL NUCLEAR MATERIALS SAFEGUARDS

Pursuant to the Atomic Energy Act of 1954, as amended, and Title 10, Code of Federal Regulations, Chapter 1, Part 70, the following amendment to the special nuclear material license identified below is hereby issued, incorporating controls for the safeguarding of special nuclear material.

Licensee

Name: Westinghouse Electric
Corporation

License No. SNM-338

Amendment No. SG-1A

Address: 3 Gateway Center, Box 3378
Pittsburgh, Pennsylvania
15230

Docket No. 70-337

CONDITIONS

1.0 FACILITY ORGANIZATION

- 1.1 The Manager, Cheswick Plant Operations, Manufacturing Department, Nuclear Fuel Division (NFD), shall have the responsibility for developing, revising, implementing, and enforcing the nuclear material control procedures and managing an overall system of special nuclear material control.
- 1.2 Nuclear material control procedures and revisions thereto shall be approved by the Manager, Nuclear Materials Safeguards, Manufacturing Department, NFD, and the Manager, Cheswick Plant Operations, Manufacturing Department, NFD. A manual containing all current nuclear material control procedures shall be maintained by the Manager, Nuclear Materials Safeguards, Manufacturing Department, NFD.

- 1.3 The Manager, Nuclear Materials Safeguards, Manufacturing Department, NFD, shall assure that the nuclear material control procedures are appropriately reflected in process specifications, manufacturing instructions, standard operating procedures, or similar detailed management instructions.
- 1.4 All delegations of safeguards responsibilities by the Manager, Cheswick Plant Operations, Manufacturing Department, NFD, shall be in writing.
- 2.0 FACILITY OPERATION
- 2.1 Material Balance Areas (MBA's) shall be established by the Manager, Nuclear Materials Safeguards, Manufacturing Department, NFD.
- 2.2 Each MBA shall be an identifiable physical area into and out of which movement of special nuclear material can be measured.
- 2.3 Sufficient numbers of MBA's shall be established so that losses of special nuclear material can be identified and localized.
- 2.4 All operations within an MBA shall be the responsibility of a single employee who shall also be responsible for the custody of special nuclear material within his MBA.
- 3.0 MEASUREMENTS AND STATISTICAL CONTROLS
- 3.1 The licensee shall determine the U-235 content of all receipts, shipments and measured discards. The U-235 content shall also be determined for all material inventoried. The limits of error* associated with these quantities shall be determined. Sufficient measurements shall be made to substantiate the stated quantities and associated limits of error.
- 3.2 A program of standardization and calibration of measurement equipment and analytical procedures shall be maintained to provide data to substantiate the limits of error associated with all measurements required for safeguards purposes.

* Limits of error as used herein means the boundaries within which the true (best) value of the parameter being measured lies with a probability of 95%.

- 3.3 All measurements required by this amendment shall be reviewed annually by the Manager of Quality Assurance, Manufacturing Department, NFD. This review shall include a quantitative calculation of limits of error of the measurement system. The Manager of Quality Assurance, Manufacturing Department, NFD, shall utilize data obtained through calibrations specified in Condition 3.2 to monitor performance of the measurement system to assure calculated limits of error are maintained between reviews. Records of reviews, calculations, and use of calibration data shall be kept by the Quality Assurance Department, Manufacturing Department, NFD.
- 3.4 After any physical inventory the material unaccounted for (MUF) and the limits of error associated with the material unaccounted for shall be computed promptly. The limits of error associated with MUF shall be calculated by statistically combining the limits of error determined for shipments, receipts, beginning inventory, ending inventory, and measured losses for the period since the last inventory.
- 3.5 If the quantity of MUF exceeds the associated limits of error, the licensee shall promptly notify the Atomic Energy Commission, Division of Nuclear Materials Safeguards, District I Office, Newark, New Jersey. The licensee shall investigate the MUF and notify the Division of Nuclear Materials Safeguards within thirty (30) days after the initial notice, specifying the probable reasons for the MUF and the corrective action taken or planned.
- 4.0 SHIPPING AND RECEIVING
- 4.1 All shipper-receiver differences shall be brought to the attention of the Manager, Nuclear Materials Safeguards, Manufacturing Department, NFD, who shall evaluate these differences to determine whether they are statistically significant and of sufficient magnitude to warrant investigation. The Manager, Nuclear Materials Safeguards, Manufacturing Department, NFD, shall investigate all statistically significant differences which exceed \$500 value. A shipper-receiver difference shall be considered statistically

significant when (1) the difference exceeds the statistical combination of the limits of error of the shipper's and receiver's measurements, or (2) if the shipper's limits of error is unknown, the difference exceeds twice the limits of error for the receiver's measurement. Statistical analyses of past performance, measurement uncertainties, and other data shall be kept by the Manager, Nuclear Materials Safeguards, Manufacturing Department, NFD.

5.0 STORAGE AND INTERNAL TRANSFERS

- 5.1 A documented system of control over special nuclear material stored and processed within the facility shall be maintained which will provide continuous knowledge of the location, and quantity of all material contained in discrete, identifiable items or containers.
- 5.2 All transfers of special nuclear material between MBA's shall be documented to show the identity, quantity, and isotopic analysis of the material transferred. A system of controls shall be maintained by the licensee for the distribution and accounting of all transfer documents.
- 5.3 Each document supporting a transfer of material between MBA's shall be signed by the delegated individual.

6.0 INVENTORY

- 6.1 A complete physical inventory of all special nuclear material subject to this license shall be conducted at approximately twelve-month intervals, but in no case shall more than fourteen months elapse between inventories.
- 6.2 Prior to each complete physical inventory, written procedures shall be prepared which:
 - 6.2.1 specify the extent to which each MBA is to shut down and clean out process equipment;

- 6.2.2 specify the extent to which each MBA is to remain static during the inventory;
 - 6.2.3 identify the basis for accepting for inventory purposes previously made measurements and their limits of error;
 - 6.2.4 designate measurements to be made for inventory purposes to establish and demonstrate the limits of error associated with the quantity of material on inventory; and
 - 6.2.5 identify the manner by which material on inventory will be listed to assure each item is inventoried and there are no duplications or omissions.
- 6.3 The book inventory shall be reconciled with and adjusted to the results of the physical inventory upon completion of the physical inventory.
- 6.4 Special physical inventories of an MBA shall be conducted whenever there is reason to believe that subsequent to the last prior physical inventory a particular MBA has experienced losses or gains that are different by a statistically significant amount from those expected.
- 7.0 RECORDS AND REPORTS
- 7.1 The licensee shall establish and maintain a records system which will provide sufficient information to maintain a material balance around each MBA and the total plant. These records shall contain information pertaining to all receipts, shipments, measured discards, inventory, and MUF for each material balance. MBA and plant records shall be reconciled at the end of each accounting period. All entries in the records shall be supported by appropriate documents.
- 7.2 All measured discards and MUF shall be reported on a monthly basis by the Manager, Nuclear Materials Safeguards, Manufacturing Department, NFD, to the Manager of Cheswick Plant Operations, Manufacturing Department, NFD.

License No. SNM-338

Page 6 of 6 pages

Amendment No. SG-1A

Docket No. 70-337

8.0 MANAGEMENT OF MATERIALS CONTROL SYSTEM

- 8.1** Licensee management, independent of the Manager, Nuclear Materials Safeguards, Manufacturing Department, NFD, shall conduct, at least once each year, an internal review of the nuclear materials control procedures and management of the overall system of special nuclear material control, and report the findings to the Manager, NFD Manufacturing Department and the General Manager, NFD.
- 8.2** An estimate of anticipated losses (measured discards plus MUF) for each period of time between inventories shall be prepared for each MBA, with the concurrence of the Manager, Nuclear Materials Safeguards and the Manager, Cheswick Plant Operations of the Manufacturing Department, NFD, and shall be based on prior experience, throughput quantities and rates, etc. If losses exceed the estimate of those anticipated, they shall be investigated by the Manager, Production Control, Cheswick Plant Operations, Manufacturing Department, NFD, and the results of his investigation shall be reported to the Manager, Cheswick Plant Operations, the Manager, Nuclear Materials Safeguards, the Manager, Manufacturing Controls of the Manufacturing Department, NFD, and the Manager, Manufacturing Department, NFD.
- 8.3** Any apparent loss of a discrete item or container of special nuclear material which cannot be resolved by an immediate investigation shall be reported to the Manager, Cheswick Plant Operations, Manufacturing Department, NFD, who shall promptly notify the Atomic Energy Commission, Division of Nuclear Materials Safeguards, District I Office, Newark, New Jersey, and shall conduct an investigation of the loss. The Manager, Cheswick Plant Operations, Manufacturing Department, NFD, shall report the results of his investigation to the Manager, Manufacturing Department, NFD.

FOR THE ATOMIC ENERGY COMMISSION

Date of Amendment _____

Division of Nuclear Materials
Safeguards



UNITED STATES
ATOMIC ENERGY COMMISSION
WASHINGTON, D.C. 20545

JUL 23 1968

Crocket
~~*Wilson*~~
Lorenz

R. W. Kirkman, Director, Region I, Division of Compliance

SURVEY NO. NY-250, "SURVEY OF SAFEGUARDS CONTROL AND MANAGEMENT OF SS MATERIALS AT WESTINGHOUSE ELECTRIC CORPORATION, ATOMIC POWER DIVISION, FACILITY MCY"

Enclosed for your information and retention is the subject New York survey for the period May 1, 1967 through March 31, 1968. We do not plan to send a letter to this facility.

Vincent J. D'Amico

Vincent J. D'Amico
Assistant Director for Operations
Division of Nuclear Materials
Safeguards

Enclosure:
Subj. Survey No. NY-250
cc w/o encl: L.D. Low, CO

CL 259

ITEM # 260

16

SURVEY OF SAFEGUARDS CONTROL AND MANAGEMENT OF SS MATERIALS AT WESTINGHOUSE
ELECTRIC CORPORATION, ATOMIC POWER DIVISION, FACILITY MCY

I. Introduction

The Atomic Power Division engages in diversified operations using plutonium and enriched uranium i.e. power reactor core manufacturing and fabrication studies, reactor lattice studies, teaching of reactor operations and analytical services. Each of these activities are performed in separate material balance areas.

The review covers SS material activities for the period May 1, 1967 through March 31, 1968. The field review did not cover all material held by the Atomic Power Division under New York's responsibility because of the geographic locations of the material balance areas and diverse nature of work performed at the areas. Survey No. NY-245 reviewed material holdings under the accounts SNM-338 and supply agreement TAS. This review covered material held under all other accounts namely:

| <u>Account</u> | <u>Quantity (g) as of 3/31/68</u> | | |
|-----------------|-----------------------------------|------------------|--------------------|
| | <u>Plutonium</u> | <u>Uranium</u> | <u>Uranium-235</u> |
| E-42002-01-01 | | 2,926 | 2,726 |
| M-40161-01-02 | 1,804 | 9,134 | 8,506 |
| J-46001-02-01 | | 42,088 | 2,244 |
| D-AT(30-1)-3017 | 19 | 2,655 | 57 |
| M-40101-02-02 | 284 | 117,236 | 1,950 |
| M-40301-01-04 | | 3,363 | 272 |
| SNM-38 | | 461 | 31 |
| SNM-738 | 64 | 207 | 16 |
| <u>SNM-770</u> | 276 | 42,266 | 3,212 |
| SNM-785 | | 60,473 | 1,659 |
| SNM-783 | | <u>2,998,588</u> | <u>100,567</u> |
| | 2,447 | 3,279,397 | 121,240 |

II. Scope of Work

The safeguards review covered:

- A. An independent test of the inventory.
- B. An evaluation of losses and material unaccounted for.

- C. An evaluation of measurements pertaining to inventory control.
- D. Internal records, reports to the Commission and accounting procedures.
- E. Statistical Techniques.
- F. Procedure Manual.
- G. Internal Control.

The portions of the review pertaining to material management functions i.e. utilization and forecasting, appear in the appendix of this report.

III. Opinion Statement

It is our opinion that all material reports submitted to the Commission for the period under review were accurately stated. The inventory positions as of March 31, 1968 were fairly presented. The internal control procedures are adequate for safeguards of SS material. The material unaccounted for, process losses and shipper/receiver differences for the period under review were reasonable.

IV. Recommendations

A. Prior Recommendations

None.

B. Current Recommendations

None.

V. Discussion

A. Inventory Verification

A prior physical inventory had been performed at each material balance area. The survey team was presented a listing of each of the items on hand. The uranium inventory consisted of various enrichments in the form of irradiated and non-irradiated fuel rods, virgin uranium metal, uranium oxide pellets, powders and dried sludge. The plutonium inventory was in the form of irradiated fuel rods, neutron sources and uranium plutonium blends.

The irradiated fuel rods were observed; their supporting records were reviewed, no other tests were performed.

The non-irradiated fuel pins (5200) were located in 12 sealed bins and in a reactor lattice. Each of the bins were inspected. The quantities assigned to each bin was reasonable. The reactor lattice was counted. The fuel pins contained uranium oxide pellets of four different enrichments; 10 pins of each enrichment (4) were weighed. The components were also weighed to establish a tare weight. An average uranium oxide weight for each enrichment was determined; these weights agreed with the nominal uranium oxide weight for the fuel pins. Each of the selected fuel pins were also gamma scanned using the portable gamma spectrometer. The gamma scan indicated that the U-235 values assigned to the pins were reasonable. Pellets of each enrichment were also weighed and gamma counted for U-235 content. These tests indicated that acceptable values were assigned to the pellets.

A population of uranium oxide powders and sludges were established. Items were selected as per MIL STD 105D at an AQL of 1.5%. Eight items from this population were checkweighed and samples were forwarded to the New Brunswick Laboratory for assay. Three samples of major items on inventory such as 93% enriched uranium metal and plutonium metal were also sent to NBL for assay. The results indicated that acceptable SS contents were assigned to items. The SS content of less than 1% of the items of inventory was estimated. However, a good portion of the items were assigned values based upon shipper's measurements. These items were mainly in the form of irradiated fuel rods.

B. Losses, Loss Mechanisms and Material Unaccounted For

All normal operational losses, material unaccounted for, accidental losses, write offs and shipper/receiver differences for the survey period were reviewed. There were no items in these categories which were considered unreasonable or excessive.

C. Measurements

The only measurements of SS materials performed during the survey period were weighings. Although there is no formal scale and balance program at the facility, it was noted that the scales are periodically calibrated and that standard NBS weights are available.

Previous review of analytical measurement procedures indicated that uranium isotopic analyses are performed as outlined in "Selected Measurement Methods".

D. Internal Records, Reports to the Commission and Accounting Procedures

The facility maintains a double entry record system for safeguards control, Commission contract material and leased material. An examination of this system indicated that all records are adequately maintained to show the inventory on a monthly basis. Accounting procedures are acceptable for control of SS materials. The material status reports and material balance reports submitted during the survey period fairly presented the transactions for their respective periods.

E. Statistical Techniques

There was no use of statistical techniques for control of SS material during the survey period. It is the opinion of the survey team that the level of activities was such that statistics were not applicable for material control.

D. Procedure Manual

A safeguards Procedure Manual has been submitted to the Division of Regulation for approval. Since the Division of Regulation has been reviewing the manual and will offer approval when some specific aspects of material control are included in the manual, no comments are being offered concerning the manual.

G. Internal Control

This review was performed by reviewing the SS Representatives responses to the internal control questionnaire. It was noted that the responses were consistent with the procedures followed by the facility. It is the opinion of the survey team that acceptable internal control practices were being maintained.

SURVEY OF MANAGEMENT OF NUCLEAR MATERIALS AT THE ATOMIC POWER DIVISION OF WESTINGHOUSE ELECTRIC CORPORATION, FACILITY MCY

APPENDIX

I. Opinion

It is our opinion that Facility MCY did satisfactorily meet AEC standards for SS material management.

II. Summary of Findings

A. Prior Recommendations

None.

B. Current Recommendations

None.

C. Prior Suggestions

Survey No. NY-235 suggested that the facility forward SS material which is no longer being used under AEC contracts to either production channels or to waste burial.

The survey team noted that excess SS materials had been forwarded to production channels.

D. Current Suggestions

None.

III. Discussion

Utilization

The survey team noted that there were no excessive quantities of virgin material on hand nor was there quantities of scrap that could be returned to production channels.

SURVEY NO. NY-250

Forecasts

Forecasts submitted during the survey period were timely and accurate.



I. Cohen, Team Leader



Date



P. J. DeLorenzo, Auditor



Date

UNITED STATES ATOMIC ENERGY COMMISSION
MATERIAL STATUS REPORT
FOR SPECIAL NUCLEAR MATERIALS HELD UNDER LICENSE
PREPARE A SEPARATE REPORT FOR EACH LICENSE

| | | | |
|--|-------------------------------|------------------------------------|----------------|
| 1. REPORTING LICENSEE: | | c. License No. <u>EX-11</u> | |
| a. Name <u>WESTINGHOUSE ATOMIC POWER DIV</u> | | d. Period Ending <u>3/31/68</u> | |
| b. Address <u>2000 WESTINGHOUSE BLDG, PITTSBURGH, PA. 15205</u> | | | |
| 2. MATERIAL: (Prepare separate report for each material) <u>ENRICHED URANIUM</u> | 3. WEIGHT UNIT <u>GRAM</u> | 4. TOTAL QUANTITY AND ISOTOPE DATA | |
| 5. BEGINNING INVENTORY: | | a. ELEMENT | b. ISOTOPE |
| 6. RECEIPTS: | | - - - | - - - |
| From _____ Shipper's License No. _____ | | | |
| 7. TOTAL RECEIPTS | | | |
| 8. PRODUCTION | | | |
| 9. MATERIAL TO BE ACCOUNTED FOR (Total of lines 5, 7, and 8). | | | |
| 10. SHIPMENTS: | | | |
| To _____ Consignee's License No. _____ | | | |
| 11. TOTAL SHIPMENTS | | | |
| 12. PROCESSING LOSSES, DISCARDS, ETC.: | | | |
| a. MATERIAL FOR WHICH THE REPORTING LICENSEE IS FINANCIALLY RESPONSIBLE | | | |
| b. MATERIAL FOR WHICH THE REPORTING LICENSEE IS NOT FINANCIALLY RESPONSIBLE | | | |
| 13. BURN-UP | | | |
| 14. ENDING INVENTORY | | - - - | - - - |
| 15. MATERIAL ACCOUNTED FOR (Total of lines 11, 12a, 12b, 13 and 14). | | | |
| 16. DETAIL OF ENDING INVENTORY: | | | |
| a. MATERIAL ON HAND FOR WHICH REPORTING LICENSEE IS FINANCIALLY RESPONSIBLE TO THE AEC UNDER ABOVE LICENSE. | | | |
| b. MATERIAL ON HAND FOR WHICH SOMEONE OTHER THAN REPORTING LICENSEE IS FINANCIALLY RESPONSIBLE TO THE AEC (Detail below) | | | |
| Name _____ License No. _____ | | | |
| c. Total of a. and b. | | | |
| 17. MATERIAL IN POSSESSION OF OTHERS FOR WHICH REPORTING LICENSEE IS FINANCIALLY RESPONSIBLE TO THE AEC UNDER ABOVE LICENSE (Detail below) | | | |
| Name <u>WESTINGHOUSE ATOMIC POWER DIV</u> Possessor's License No. <u>SAM-783</u> | | <u>8606.74</u> | <u>8616.90</u> |
| TOTAL: | | | |

MATERIAL STATUS REPORT

FOR SPECIAL NUCLEAR MATERIALS HELD UNDER LICENSE
PREPARE A SEPARATE REPORT FOR EACH LICENSE

| | | | |
|--|---|------------------------------------|-----------------|
| 1. REPORTING LICENSEE: | | | |
| a. Name | <u>WEST VIRGINIA STATE ATOMIC POWER DIV</u> | c. License No. | <u>5411-738</u> |
| b. Address | <u>1001 31ST STREET, PITTSBURGH, PA. 15222</u> | d. Period Ending | <u>3/31/68</u> |
| 2. MATERIAL: (Prepare separate report for each material) | 3. WEIGHT UNIT | 4. TOTAL QUANTITY AND ISOTOPE DATA | |
| <u>PLUTONIUM</u> | <u>GRAMS</u> | a. ELEMENT | b. ISOTOPE |
| 5. BEGINNING INVENTORY: | <u>JAN 1, 1968</u> | <u>63.99</u> | <u>59.53</u> |
| 6. RECEIPTS: | | | |
| From | Shipper's License No. | | |
| | | | |
| | | | |
| | | | |
| 7. TOTAL RECEIPTS | | | |
| 8. PRODUCTION | | | |
| 9. MATERIAL TO BE ACCOUNTED FOR (Total of lines 5, 7, and 8). | | <u>63.99</u> | <u>59.53</u> |
| 10. SHIPMENTS: | | | |
| To | Consignee's License No. | | |
| | | | |
| | | | |
| | | | |
| 11. TOTAL SHIPMENTS | | | |
| 12. PROCESSING LOSSES, DISCARDS, ETC.: | | | |
| a. MATERIAL FOR WHICH THE REPORTING LICENSEE IS FINANCIALLY RESPONSIBLE | | | |
| b. MATERIAL FOR WHICH THE REPORTING LICENSEE IS NOT FINANCIALLY RESPONSIBLE | | | |
| 13. BURN-UP | | | |
| 14. ENDING INVENTORY <u>3/31/68 PHYSICAL INVENTORY</u> | | <u>63.99</u> | <u>59.53</u> |
| 15. MATERIAL ACCOUNTED FOR (Total of lines 11, 12a, 12b, 13 and 14). | | | |
| 16. DETAIL OF ENDING INVENTORY: | | | |
| a. MATERIAL ON HAND FOR WHICH REPORTING LICENSEE IS FINANCIALLY RESPONSIBLE TO THE AEC UNDER ABOVE LICENSE. | | | |
| b. MATERIAL ON HAND FOR WHICH SOMEONE OTHER THAN REPORTING LICENSEE IS FINANCIALLY RESPONSIBLE TO THE AEC (Detail below) | | | |
| Name | License No. | | |
| | | | |
| | | | |
| | | | |
| c. Total of a. and b. | | | |
| 17. MATERIAL IN POSSESSION OF OTHERS FOR WHICH REPORTING LICENSEE IS FINANCIALLY RESPONSIBLE TO THE AEC UNDER ABOVE LICENSE (Detail below) | | | |
| Name | Possessor's License No. | | |
| | | | |
| | | | |
| | | | |
| TOTALS | | | |

UNITED STATES ATOMIC ENERGY COMMISSION
MATERIAL STATUS REPORT

FOR SPECIAL NUCLEAR MATERIALS HELD UNDER LICENSE
PREPARE A SEPARATE REPORT FOR EACH LICENSE

| | | | |
|--|---------------------------------------|------------------------------------|-------------------|
| 1. REPORTING LICENSEE: | | | |
| a. Name | <u>WESTINGHOUSE Atomic Power Div.</u> | c. License No. | <u>783 Z4P</u> |
| b. Address | <u>Box 355, Pittsburh, PA. 15230</u> | d. Period Ending | <u>3/31/68</u> |
| 2. MATERIAL: (Prepare separate report for each material) | 3. WEIGHT UNIT | 4. TOTAL QUANTITY AND ISOTOPE DATA | |
| <u>ENRICHED URANIUM</u> | <u>GRAMS</u> | a. ELEMENT | b. ISOTOPE |
| 5. BEGINNING INVENTORY: | <u>JAN. 1, 1968</u> | <u>2,988,587.74</u> | <u>100,566.89</u> |
| 6. RECEIPTS: | | | |
| From | Shipper's License No. | | |
| | | | |
| | | | |
| | | | |
| 7. TOTAL RECEIPTS | | | |
| 8. PRODUCTION | | | |
| 9. MATERIAL TO BE ACCOUNTED FOR (Total of lines 5, 7, and 8). | | <u>2,988,587.74</u> | <u>100,566.89</u> |
| 10. SHIPMENTS: | | | |
| To | Consignee's License No. | | |
| | | | |
| | | | |
| | | | |
| 11. TOTAL SHIPMENTS | | | |
| 12. PROCESSING LOSSES, DISCARDS, ETC.: | | | |
| a. MATERIAL FOR WHICH THE REPORTING LICENSEE IS FINANCIALLY RESPONSIBLE | | | |
| b. MATERIAL FOR WHICH THE REPORTING LICENSEE IS NOT FINANCIALLY RESPONSIBLE | | | |
| 13. BURN-UP | | | |
| 14. ENDING INVENTORY | <u>3/31/68 PHYSICAL INVENTORY</u> | <u>2,988,587.74</u> | <u>100,566.89</u> |
| 15. MATERIAL ACCOUNTED FOR (Total of lines 11, 12a, 12b, 13 and 14). | | | |
| 16. DETAIL OF ENDING INVENTORY: | | | |
| a. MATERIAL ON HAND FOR WHICH REPORTING LICENSEE IS FINANCIALLY RESPONSIBLE TO THE AEC UNDER ABOVE LICENSE. | | | |
| b. MATERIAL ON HAND FOR WHICH SOMEONE OTHER THAN REPORTING LICENSEE IS FINANCIALLY RESPONSIBLE TO THE AEC (Detail below) | | | |
| Name | License No. | | |
| | | | |
| | | | |
| | | | |
| c. Total of a. and b. | | | |
| 17. MATERIAL IN POSSESSION OF OTHERS FOR WHICH REPORTING LICENSEE IS FINANCIALLY RESPONSIBLE TO THE AEC UNDER ABOVE LICENSE (Detail below) | | | |
| Name | Possessor's License No. | | |
| | | | |
| | | | |
| | | | |
| TOTAL | | | |

UNITED STATES ATOMIC ENERGY COMMISSION
MATERIAL STATUS REPORT
FOR SPECIAL NUCLEAR MATERIALS HELD UNDER LICENSE
PREPARE A SEPARATE REPORT FOR EACH LICENSE

| | | | |
|--|-------------------------------|------------------------------------|---------------|
| 1. REPORTING LICENSEE: | | | |
| a. Name <u>WASHINGTON ATOMIC POWER DIV</u> | | c. License No. <u>770 249</u> | |
| b. Address <u>PO BOX 351 PITTSBURGH PA 15230</u> | | d. Period Ending <u>3/31/67</u> | |
| 2. MATERIAL: (Prepare separate report for each material) <u>PLUTONIUM</u> | 3. WEIGHT UNIT <u>GRAM</u> | 4. TOTAL QUANTITY AND ISOTOPE DATA | |
| 5. BEGINNING INVENTORY: <u>JUN 1 1964</u> | | a. ELEMENT | b. ISOTOPE |
| 6. RECEIPTS: | | <u>219.44</u> | <u>199.90</u> |
| From _____ Shipper's License No. _____ | | | |
| <u>SAXTON NUCLEAR</u> <u>DPR-4-13</u> | | <u>56.70</u> | <u>48.76</u> |
| 7. TOTAL RECEIPTS | | <u>56.70</u> | <u>48.76</u> |
| 8. PRODUCTION | | | |
| 9. MATERIAL TO BE ACCOUNTED FOR (Total of lines 5, 7, and 8). | | <u>275.64</u> | <u>248.16</u> |
| 10. SHIPMENTS: | | | |
| To _____ Consignee's License No. _____ | | | |
| 11. TOTAL SHIPMENTS | | | |
| 12. PROCESSING LOSSES, DISCARDS, ETC.: | | | |
| a. MATERIAL FOR WHICH THE REPORTING LICENSEE IS FINANCIALLY RESPONSIBLE | | | |
| b. MATERIAL FOR WHICH THE REPORTING LICENSEE IS NOT FINANCIALLY RESPONSIBLE | | | |
| 13. BURN-UP | | | |
| 14. ENDING INVENTORY <u>3/31/67 PHYSICAL INVENTORY</u> | | <u>275.64</u> | <u>248.16</u> |
| 15. MATERIAL ACCOUNTED FOR (Total of lines 11, 12a, 12b, 13 and 14). | | | |
| 16. DETAIL OF ENDING INVENTORY: | | | |
| a. MATERIAL ON HAND FOR WHICH REPORTING LICENSEE IS FINANCIALLY RESPONSIBLE TO THE AEC UNDER ABOVE LICENSE. | | | |
| b. MATERIAL ON HAND FOR WHICH SOMEONE OTHER THAN REPORTING LICENSEE IS FINANCIALLY RESPONSIBLE TO THE AEC (Detail below) | | | |
| Name _____ License No. _____ | | | |
| c. Total of a. and b. | | | |
| 17. MATERIAL IN POSSESSION OF OTHERS FOR WHICH REPORTING LICENSEE IS FINANCIALLY RESPONSIBLE TO THE AEC UNDER ABOVE LICENSE (Detail below) | | | |
| Name _____ Possessor's License No. _____ | | | |
| TOTALS | | | |

UNITED STATES ATOMIC ENERGY COMMISSION
MATERIAL STATUS REPORT

FOR SPECIAL NUCLEAR MATERIALS HELD UNDER LICENSE
PREPARE A SEPARATE REPORT FOR EACH LICENSE

| | | | |
|--|---------------------------------------|------------------------------------|----------------|
| 1. REPORTING LICENSEE: | | | |
| a. Name | <u>WESTINGHOUSE ATOMIC POWER DIV.</u> | c. License No. | <u>SNM-738</u> |
| b. Address | <u>60315 PITTSBURGH, PA 15230</u> | d. Period Ending | <u>3/31/68</u> |
| 2. MATERIAL: (Prepare separate report for each material) | 3. WEIGHT UNIT | 4. TOTAL QUANTITY AND ISOTOPE DATA | |
| <u>ENRICHED URANIUM</u> | <u>GRAM</u> | a. ELEMENT | b. ISOTOPE |
| 5. BEGINNING INVENTORY: <u>JAN. 1, 1964</u> | | <u>206.65</u> | <u>16.40</u> |
| 6. RECEIPTS: | | | |
| From | Shipper's License No. | | |
| | | | |
| | | | |
| | | | |
| 7. TOTAL RECEIPTS | | | |
| 8. PRODUCTION | | | |
| 9. MATERIAL TO BE ACCOUNTED FOR (Total of lines 5, 7, and 8). | | <u>206.65</u> | <u>16.40</u> |
| 10. SHIPMENTS: | | | |
| To | Consignee's License No. | | |
| | | | |
| | | | |
| | | | |
| 11. TOTAL SHIPMENTS | | | |
| 12. PROCESSING LOSSES, DISCARDS, ETC.: | | | |
| a. MATERIAL FOR WHICH THE REPORTING LICENSEE IS FINANCIALLY RESPONSIBLE | | | |
| b. MATERIAL FOR WHICH THE REPORTING LICENSEE IS NOT FINANCIALLY RESPONSIBLE | | | |
| 13. BURN-UP | | | |
| 14. ENDING INVENTORY | <u>2/3/68 PHYSICAL INVENTORY</u> | <u>206.65</u> | <u>16.40</u> |
| 15. MATERIAL ACCOUNTED FOR (Total of lines 11, 12a, 12b, 13 and 14). | | | |
| 16. DETAIL OF ENDING INVENTORY: | | | |
| a. MATERIAL ON HAND FOR WHICH REPORTING LICENSEE IS FINANCIALLY RESPONSIBLE TO THE AEC UNDER ABOVE LICENSE. | | | |
| b. MATERIAL ON HAND FOR WHICH SOMEONE OTHER THAN REPORTING LICENSEE IS FINANCIALLY RESPONSIBLE TO THE AEC (Detail below) | | | |
| Name | License No. | | |
| | | | |
| | | | |
| | | | |
| c. Total of a. and b. | | | |
| 17. MATERIAL IN POSSESSION OF OTHERS FOR WHICH REPORTING LICENSEE IS FINANCIALLY RESPONSIBLE TO THE AEC UNDER ABOVE LICENSE (Detail below) | | | |
| Name | Possessor's License No. | | |
| | | | |
| | | | |
| | | | |
| TOTAL | | | |

MATERIAL STATUS REPORT

FOR SPECIAL NUCLEAR MATERIALS HELD UNDER LICENSE
PREPARE A SEPARATE REPORT FOR EACH LICENSE

REPORTING LICENSEE: WESTINGHOUSE ATOMIC POWER DIV c. License No. CX-11
Box 351, Pittsburgh Pa 15230 d. Period Ending 3/31/68

| 1. (Prepare separate report for each material) 2. REPORTING LICENSEE'S NAME AND ADDRESS | 3. WEIGHT UNIT | 4. TOTAL QUANTITY AND ISOTOPE DATA | |
|--|----------------|------------------------------------|----------------|
| | | a. ELEMENT | b. ISOTOPE |
| REPORTING INVENTORY: | GRAM | - | - |
| 5: | | | |
| Shipper's License No. | | | |
| RECEIPTS | | | |
| 6. ION | | | |
| 7. TO BE ACCOUNTED FOR (Total of lines 5, 7, and 8). | | | |
| 8: | | | |
| Consignee's License No. | | | |
| 9. COMMENTS | | | |
| 10. LOSSES, DISCARDS, ETC.: | | | |
| FOR WHICH THE REPORTING LICENSEE IS FINANCIALLY RESPONSIBLE | | | |
| FOR WHICH THE REPORTING LICENSEE IS NOT FINANCIALLY RESPONSIBLE | | | |
| 11. REPORTING INVENTORY: | | | |
| IN HAND FOR WHICH REPORTING LICENSEE IS FINANCIALLY RESPONSIBLE TO THE AEC UNDER ABOVE LICENSE. | | | |
| IN HAND FOR WHICH SOMEONE OTHER THAN REPORTING LICENSEE IS FINANCIALLY RESPONSIBLE TO THE AEC (Detail below) | | | |
| License No. | | | |
| 12. POSSESSION OF OTHERS FOR WHICH REPORTING LICENSEE IS FINANCIALLY RESPONSIBLE TO THE AEC UNDER ABOVE LICENSE (Detail below) | | | |
| Possessor's License No. | | | |
| <u>Atomic Power Div</u> <u>511A-783</u> | | <u>8606-74</u> | <u>8016-30</u> |

UNITED STATES ATOMIC ENERGY COMMISSION
MATERIAL STATUS REPORT

FOR SPECIAL NUCLEAR MATERIALS HELD UNDER LICENSE
PREPARE A SEPARATE REPORT FOR EACH LICENSE

| | | | |
|--|--|---------------------------------------|---|
| 1. REPORTING LICENSEE: | | | |
| a. Name <u>WESTINGHOUSE ATOMIC POWER DIV.</u> | | c. License No. <u>SN 337</u> | |
| b. Address <u>Box 351, Pittsburgh, PA 15230</u> | | d. Period Ending <u>2/3/68</u> | |
| 2. MATERIAL: (Prepare separate report for each material) <u>EMPLOYED MATERIAL</u> | | 3. WEIGHT UNIT <u>GRAMS</u> | 4. TOTAL QUANTITY AND ISOTOPE DATA |
| | | a. ELEMENT | b. ISOTOPE |
| 5. BEGINNING INVENTORY: <u>JAN 1, 1967</u> | | <u>253.00</u> | <u>18.79</u> |
| 6. RECEIPTS: | | | |
| From _____ Shipper's License No. _____ | | | |
| <u>WESTINGHOUSE</u> <u>SN 337-C580</u> | | <u>202.00</u> | <u>12.00</u> |
| | | | |
| 7. TOTAL RECEIPTS | | <u>202.00</u> | <u>12.00</u> |
| 8. PRODUCTION | | | |
| 9. MATERIAL TO BE ACCOUNTED FOR (Total of lines 5, 7, and 8). | | <u>461.00</u> | <u>30.79</u> |
| 10. SHIPMENTS: | | | |
| To _____ Consignee's License No. _____ | | | |
| | | | |
| | | | |
| 11. TOTAL SHIPMENTS | | | |
| 12. PROCESSING LOSSES, DISCARDS, ETC.: | | | |
| a. MATERIAL FOR WHICH THE REPORTING LICENSEE IS FINANCIALLY RESPONSIBLE | | | |
| b. MATERIAL FOR WHICH THE REPORTING LICENSEE IS NOT FINANCIALLY RESPONSIBLE | | | |
| 13. BURN-UP | | | |
| 14. ENDING INVENTORY <u>STATUS PHYSICAL INVENTORY</u> | | <u>461.00</u> | <u>30.79</u> |
| 5. MATERIAL ACCOUNTED FOR (Total of lines 11, 12a, 12b, 13 and 14). | | | |
| 6. DETAIL OF ENDING INVENTORY: | | | |
| a. MATERIAL ON HAND FOR WHICH REPORTING LICENSEE IS FINANCIALLY RESPONSIBLE TO THE AEC UNDER ABOVE LICENSE. | | | |
| b. MATERIAL ON HAND FOR WHICH SOMEONE OTHER THAN REPORTING LICENSEE IS FINANCIALLY RESPONSIBLE TO THE AEC (Detail below) | | | |
| Name _____ License No. _____ | | | |
| _____ | | | |
| _____ | | | |
| c. Total of a. and b. | | | |
| MATERIAL IN POSSESSION OF OTHERS FOR WHICH REPORTING LICENSEE IS FINANCIALLY RESPONSIBLE TO THE AEC UNDER ABOVE LICENSE (Detail below) | | | |
| Name _____ Possessor's License No. _____ | | | |
| _____ | | | |
| _____ | | | |
| OTA: | | | |

MATERIAL STATUS REPORT

FOR SPECIAL NUCLEAR MATERIALS HELD UNDER LICENSE
PREPARE A SEPARATE REPORT FOR EACH LICENSE

| | | | |
|--|-------------------------------|------------------------------------|--------------|
| 1. REPORTING LICENSEE: | | c. License No. <u>785 24P</u> | |
| a. Name <u>WESTINGHOUSE Atomic POWER DIV.</u> | | d. Period Ending <u>3/31/68</u> | |
| b. Address <u>61355 PITTSBURGH, PA 15220</u> | | | |
| 2. MATERIAL: (Prepare separate report for each material) <u>ENRICHED URANIUM</u> | 3. WEIGHT UNIT <u>GRAM</u> | 4. TOTAL QUANTITY AND ISOTOPE DATA | |
| | | a. ELEMENT | b. ISOTOPE |
| 5. BEGINNING INVENTORY: <u>JAN. 1, 1968</u> | | <u>60,473</u> | <u>1,659</u> |
| 6. RECEIPTS: | | | |
| From _____ | Shipper's License No. _____ | | |
| _____ | _____ | | |
| _____ | _____ | | |
| 7. TOTAL RECEIPTS | | | |
| 8. PRODUCTION | | | |
| 9. MATERIAL TO BE ACCOUNTED FOR (Total of lines 5, 7, and 8). | | <u>60,473</u> | <u>1,659</u> |
| 10. SHIPMENTS: | | | |
| To _____ | Consignee's License No. _____ | | |
| _____ | _____ | | |
| _____ | _____ | | |
| 11. TOTAL SHIPMENTS | | | |
| 12. PROCESSING LOSSES, DISCARDS, ETC.: | | | |
| a. MATERIAL FOR WHICH THE REPORTING LICENSEE IS FINANCIALLY RESPONSIBLE | | | |
| b. MATERIAL FOR WHICH THE REPORTING LICENSEE IS NOT FINANCIALLY RESPONSIBLE | | | |
| 13. BURN-UP | | | |
| 14. ENDING INVENTORY <u>3/31/68 PHYSICAL INVENTORY</u> | | <u>60,473</u> | <u>1,659</u> |
| 15. MATERIAL ACCOUNTED FOR (Total of lines 11, 12a, 12b, 13 and 14). | | | |
| 16. DETAIL OF ENDING INVENTORY: | | | |
| a. MATERIAL ON HAND FOR WHICH REPORTING LICENSEE IS FINANCIALLY RESPONSIBLE TO THE AEC UNDER ABOVE LICENSE. | | | |
| b. MATERIAL ON HAND FOR WHICH SOMEONE OTHER THAN REPORTING LICENSEE IS FINANCIALLY RESPONSIBLE TO THE AEC (Detail below) | | | |
| Name _____ | License No. _____ | | |
| _____ | _____ | | |
| _____ | _____ | | |
| c. Total of a. and b. | | | |
| 17. MATERIAL IN POSSESSION OF OTHERS FOR WHICH REPORTING LICENSEE IS FINANCIALLY RESPONSIBLE TO THE AEC UNDER ABOVE LICENSE (Detail below) | | | |
| Name _____ | Possessor's License No. _____ | | |
| _____ | _____ | | |
| _____ | _____ | | |
| TOTALS | | | |

MATERIAL STATUS REPORT

FOR SPECIAL NUCLEAR MATERIALS HELD UNDER LICENSE
PREPARE A SEPARATE REPORT FOR EACH LICENSE

| | | | |
|---|-------------------------------|------------------------------------|----------------------------|
| 1. REPORTING LICENSEE: a. Name <u>WESTINGHOUSE ATOMIC POWER DIV</u> c. License No. <u>770 241</u> b. Address <u>BOX 353 PITTSBURGH, PA. 15230</u> d. Period Ending <u>3/31/62</u> | | | |
| 2. MATERIAL: (Prepare separate report for each material) <u>ENRICHED URANIUM</u> | 3. WEIGHT UNIT <u>GRAM</u> | 4. TOTAL QUANTITY AND ISOTOPE DATA | |
| 5. BEGINNING INVENTORY: <u>JAN. 1, 1962</u> | | a. ELEMENT <u>37,450</u> | b. ISOTOPE <u>2,963</u> |
| 6. RECEIPTS: | | | |
| From | Shipper's License No. | | |
| <u>WESTINGHOUSE</u> | <u>SNM 338-35</u> | <u>51</u> | <u>3</u> |
| " | <u>SNM 338-36</u> | <u>47</u> | <u>2</u> |
| <u>SINTERED URANIUM</u> | <u>DPR-4 - 11</u> | <u>475</u> | <u>26</u> |
| " | <u>DPR-4 - 12</u> | <u>4243</u> | <u>218</u> |
| 7. TOTAL RECEIPTS | | <u>4816</u> | <u>249</u> |
| 8. PRODUCTION | | | |
| 9. MATERIAL TO BE ACCOUNTED FOR (Total of lines 5, 7, and 8). | | <u>42,266</u> | <u>3,211</u> |
| 10. SHIPMENTS: | | | |
| To | Consignee's License No. | | |
| | | | |
| | | | |
| | | | |
| 11. TOTAL SHIPMENTS | | | |
| 12. PROCESSING LOSSES, DISCARDS, ETC.: | | | |
| a. MATERIAL FOR WHICH THE REPORTING LICENSEE IS FINANCIALLY RESPONSIBLE | | | |
| b. MATERIAL FOR WHICH THE REPORTING LICENSEE IS NOT FINANCIALLY RESPONSIBLE | | | |
| 13. BURN-UP | | | |
| 14. ENDING INVENTORY <u>3/31/62 PHYSICAL INVENTORY</u> | | <u>42,266</u> | <u>3,211</u> |
| 15. MATERIAL ACCOUNTED FOR (Total of lines 11, 12a, 12b, 13 and 14). | | | |
| 16. DETAIL OF ENDING INVENTORY: | | | |
| a. MATERIAL ON HAND FOR WHICH REPORTING LICENSEE IS FINANCIALLY RESPONSIBLE TO THE AEC UNDER ABOVE LICENSE. | | | |
| b. MATERIAL ON HAND FOR WHICH SOMEONE OTHER THAN REPORTING LICENSEE IS FINANCIALLY RESPONSIBLE TO THE AEC (Detail below) | | | |
| Name | License No. | | |
| | | | |
| | | | |
| | | | |
| c. Total of a. and b. | | | |
| 17. MATERIAL IN POSSESSION OF OTHERS FOR WHICH REPORTING LICENSEE IS FINANCIALLY RESPONSIBLE TO THE AEC UNDER ABOVE LICENSE (Detail below) | | | |
| Name | Possessor's License No. | | |
| | | | |
| | | | |
| | | | |
| TOTALS | | | |

MEMO ROUTE SLIP

Form AEC-98 (Rev. May 14, 1947)

See me about this.
Note and return.

For concurrence.
For signature.

For action.
For information.

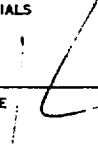
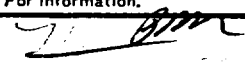
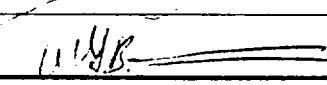
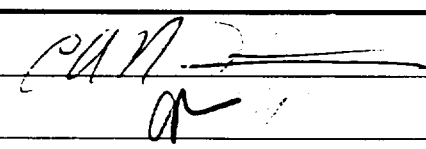
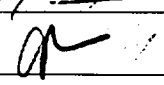
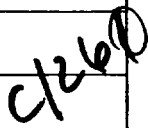
| | | |
|--|---|---|
| TO (Name and unit) REGION I COMPLIANCE | INITIALS  DATE | REMARKS   |
| TO (Name and unit) | INITIALS DATE | REMARKS Attached, in accordance with working agreement with NMM, is copy of NY Survey #235, WESTINGHOUSE ELECTRIC CORPORATION, ATOMIC POWER DIVISION (MCY) for the period February 1, 1966 to April 30, 1967. |
| TO (Name and unit) | INITIALS DATE | REMARKS   |
| FROM (Name and unit) R. G. Page BETH 010 | REMARKS | Attachment: Cpy Survey Report #235 w/cpy transmittal memo cc: L. Dubinski, CO, HQ. |
| PHONE NO. 7422 | DATE 5-31-67 | REMARKS  |

USE OTHER SIDE FOR ADDITIONAL REMARKS

U. S. GOVERNMENT PRINTING OFFICE : 1957-O-422007

ITEM # 261

79

UNITED STATES GOVERNMENT

Memorandum

TO : Ralph G. Page, Chief, Indemnity & Export Control Branch, State & Licensee Relations, REG DATE: MAY 26 1967

FROM : Ralph J. Jones, Chief, Technical Branch
Division of Nuclear Materials Management *RJ Jones*

SUBJECT: NY SURVEY #235, WESTINGHOUSE ELECTRIC CORPORATION, ATOMIC POWER DIVISION (MCY)

NMM:JVC

In accordance with the August 1, 1966, agreement between the General Manager and the Director of Regulation (Procedure for Implementing and Administering the Commission's Domestic Safeguards Program for Licensed Special Nuclear Material), two copies of the subject report are enclosed.

No recommendation or suggestions were made in the report. Westinghouse management was advised, in writing, of satisfactory safeguards control.

Enclosure:
As stated above



SURVEY OF SAFEGUARDS CONTROL AND MANAGEMENT OF SS MATERIALS AT THE ATOMIC POWER DIVISIONS OF WESTINGHOUSE ELECTRIC CORPORATION, FACILITY MCY

I. Introduction

The activities of Facility MCY cover many areas in the Nuclear Field, a few of which are: fabrication of fuel for domestic and foreign power reactors, development of fuel fabrication techniques and post irradiation studies of reactor fuel.

The review covers SS material activities for the period 2/1/66 through 4/30/67. The field review was performed during the period 4/24 - 28/67.

This review did not cover all material held by the Atomic Power Division under New York's responsibility because of the geographic locations of the material balance areas and diverse nature of work performed at the areas. New York Survey No.-231 covered material held under SNM-338 and supply agreement TAS. This review covered material held under all accounts which were not covered in Survey-231, namely:

| <u>Account</u> | <u>Quantity (g) as of 4/30/67</u> | | <u>Pu</u> |
|------------------|-----------------------------------|--------------|-----------|
| | <u>U</u> | <u>U-235</u> | |
| J-46001-02-01 | 48,521 | 2,666 | |
| E-42002-01-01 | 927 | 864 | |
| D-AT(30-1)-3017 | 45,696 | 1,116 | 257 |
| M-44002-01-08 | 20,664 | 4,343 | |
| M-40101-02-01 | 2,137,659 | 69,723 | |
| M-44002-01-06 | 1,644 | 93 | |
| SNM-38 | 44 | 11 | |
| SNM-738 | 9 | 7 | 64 |
| SNM-770 | 29,247 | 1,690 | 223 |
| SNM-783 | 869,242 | 31,418 | |
| SNM-785 | 48,311 | 1,314 | |
| Normal Uranium | * | | |
| Depleted Uranium | * | * | |

II. Scope of Work

The safeguards review covered:

- A. An independent test of the inventory.
- B. an evaluation of losses and material unaccounted for.
- C. An evaluation of measurements pertaining to inventory control.
- D. Internal records, reports to the Commission and accounting procedures.
- E. Statistical techniques.

F. Procedure Manual.

G. Internal Control.

The portions of the review pertaining to material management functions, i.e., utilization and forecasting, appear in the appendix of this report.

A
III. Opinion Statement

It is our opinion that all material reports submitted to the Commission for the period under review were accurately stated. The inventory positions as of April 30, 1967 were fairly presented. The internal control procedures are adequate for safeguards of SS materials. The material unaccounted for, process losses and shipper/receiver differences for the period under review were reasonable.

d
IV. Recommendations

A. Prior Recommendations

NY Survey No.-208 recommended that material balance area custodians at the Technical Service Laboratories and Reactor Evaluation Center be trained in Westinghouse physical inventory procedures and that on about July 1, 1966 these areas be inventoried. Prior notification should be given to New York as to the exact dates of the physical inventory so that the inventory procedure can be observed.

B. Action on Recommendations

Notification was given to this office that a physical inventory would be taken during the month of July. Members of this office were not available to observe the physical inventory procedures, however, an inventory was taken by Westinghouse. The present survey team noted that the material balance area custodians were trained in Westinghouse physical inventory procedures. Since the present inventory procedure was acceptable, this recommendation is withdrawn.

V. Discussion

A. Inventory Verification

A prior physical inventory had been performed at each material balance area. The inventory consisted of various enrichments of uranium in the form of irradiated and non-irradiated power reactor fuel rods, UO₂ pellets and UO₂ powders. The plutonium on hand was associated with the spent fuel and also in the form of neutron sources. The irradiated fuel rods which could be observed were inspected and supporting records were reviewed. The non-irradiated fuel rods were piece counted.

Since the SS content of these rods had been previously verified, no other tests were performed. Pellets and powders were placed into populations for checkweighing. Random samples were selected as per MIL STD 105D at an AQL of 1.5%. Supporting records were observed for verification of SS content of the samples of pellets and powders. The neutron sources were observed. The source material was accepted without verification.

The SS content of less than 1% of the items of material on hand was estimated by the facility, however, a good portion of the items on hand were given values based on shippers values. These items were in the form of irradiated and non-irradiated fuel rods for which independent measurement of SS content by the facility would be costly. All of the inventory test results were acceptable; the inventory, as presented, and the inventory procedures were acceptable.

B. Losses, Loss Mechanisms and Material Unaccounted For

All normal operational losses, material unaccounted for, accidental losses, write-offs, and shipper/receiver differences for the survey period were reviewed. There were no items in these categories which were considered unreasonable or excessive.

C. Measurements

An evaluation of laboratory procedures and validity of analytical measurements used for material control purposes was performed. The analytical laboratory has participated in the evaluation of selected measurement methods for plutonium and uranium in the nuclear fuel cycle. Results of spectrochemical isotopic analyses of slightly enriched uranium and highly enriched uranium were in close agreement with the reference value. Total uranium analysis for product material is performed using the gravimetric procedure outlined in "selected measurement methods." Waste materials, such as grinding sludge, are analyzed for uranium by an X-ray fluorescence method. The survey team noted that the scales and balances used for weighings of SS material are capable of producing accurate weighings. It is the opinion of the survey team that the overall measurement program is suitable for control of SS material.

D. Internal Records, Reports to the Commission and Accounting Procedures

The facility maintains a double entry record system for safeguards control, Commission contract material and leased material. An examination of this system indicated that all records are adequately maintained to show the inventory on a monthly basis. Accounting procedures are consistent with AEC standards for safeguards control of SS materials. The material status reports and material balance reports submitted during the survey period fairly presented the transactions for their respective periods.

E. Statistical Techniques

There was no use of statistical techniques for control of SS material during the survey period. It is the opinion of the survey team that the level of activity was such that statistics were not applicable for material control.

F. Procedure Manual

An approved procedure manual is in our possession. There were no major changes at the facility which would require amendments to the manual.

G. Internal Control

An evaluation of the internal control procedures was performed by reviewing the internal control questionnaire which was completed by the SS representative, inspecting product records of a current job and noting the types of measurements and measurement points for this job. These reviews indicated that acceptable internal control practices were being carried out.

I. Cohen, Team Leader

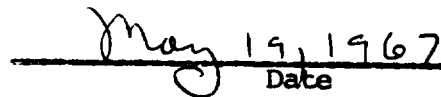
Date

P. J. DeLorenzo, Auditor

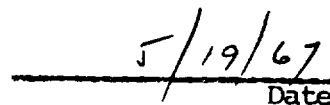
Date

SURVEY OF MANAGEMENT OF NUCLEAR MATERIALS AT THE ATOMIC POWER DIVISION
OF WESTINGHOUSE ELECTRIC CORPORATION, FACILITY MCY

APPENDIX

The portions of the review that are exclusively management functions appear in this section. Portions which reflect both safeguards control and material management appear in the safeguards section of this report.

I. Opinion

It is our opinion that Facility MCY did satisfactorily meet AEC Standards for SS material management.

II. Summary of Findings

A. Prior Recommendations

None.

B. Current Recommendations

None.

C. Current Suggestions

It is suggested that the facility forward to either production channels or dispose of SS material which is no longer being used under AEC contracts.

III. Discussion

Utilization

The survey team noted that there was material on hand for contracts which have been completed. This matter was discussed with facility management; the survey team was assured that prompt action would be taken to dispose of SS material no longer required.

Forecasts

Forecasts submitted during the survey period were timely and accurate.



I. Cohen, Team Leader

May 19, 1967
Date



P. J. DeLorenzo, Auditor

5/19/67
Date

Material Balance Report
Westinghouse Electric Corp.
Period Ending 4/30/67

| | <u>Enriched Under 75%</u> | |
|---|---------------------------|--------------|
| | <u>SS</u> | <u>U-235</u> |
| Beginning Inventory - January 1, 1966 | 2,785,186 | 57,406 |
| Receipts 1/1/66 - 4/30/67 | 48,521 | 2,666 |
| Removals 1/1/66 - 4/30/67 | 579,528 | (17,865)* |
| Ending Inventory (Per Physical) 4/30/67 | 2,254,179 | 77,937 |

*NOTE - A transfer from Facility MCY to lease A/C in prior survey NY-208 was voided during current survey period resulting in a positive removal.

**Material Balance Report
Westinghouse Electric Corp.
Period Ending 4/30/67**

| | <u>Enriched Over 75%</u> | |
|---|--------------------------|--------------|
| | <u>Grams</u> | |
| | <u>SS</u> | <u>U-235</u> |
| Beginning Inventory - January 1, 1966 | 12,877 | 11,981 |
| Receipts 1/1/66 - 4/30/67 | 4,654 | 4,334 |
| Removals 1/1/66 - 4/30/67 | 16,599 | 15,447 |
| Ending Inventory (Per Physical) 4/30/67 | <u>932</u> | <u>868</u> |

Material Balance Report
Westinghouse Electric Corp.
Period Ending 4/30/67

| | <u>Depleted U</u> | | <u>Plutonium</u> | <u>Normal</u> |
|---|-------------------|-------------------|------------------|---------------|
| | <u>SS</u> | <u>Kgs. U-235</u> | <u>Grams</u> | <u>Kgs.</u> |
| Beginning Inventory - January 1, 1966 | 1 | * | 3,593 | 4 |
| Receipts - 1/1/66 - 4/30/67 | * | * | | 1,171 |
| Removals - 1/1/66 - 4/30/67 | 1 | * | 3,336 | 1,175 |
| Ending Inventory (Per Physical) 4/30/67 | * | * | 257 | * |

MATERIAL STATUS REPORT

FOR SPECIAL NUCLEAR MATERIALS HELD UNDER LICENSE
PREPARE A SEPARATE REPORT FOR EACH LICENSE

| | | | |
|--|-------------------------------|------------------------------------|------------------|
| 1. REPORTING LICENSEE: | | c. License No. _____ | |
| a. Name <u>Westinghouse Atomic Power Division</u> | | d. Period Ending <u>783 ZYP</u> | |
| b. Address <u>Box 355, Pittsburgh, Pa. 15230</u> | | <u>4/30/67</u> | |
| 2. MATERIAL: (Prepare separate report for each material) | 3. WEIGHT UNIT | 4. TOTAL QUANTITY AND ISOTOPE DATA | |
| | | a. ELEMENT | b. ISOTOPE |
| 5. BEGINNING <u>Unenriched Uranium</u> | <u>Grams</u> | | |
| 6. RECEIPTS: <u>January 1, 1967</u> | | <u>869,241.74</u> | <u>31,415.89</u> |
| From _____ | Shipper's License No. _____ | | |
| _____ | _____ | | |
| _____ | _____ | | |
| _____ | _____ | | |
| 7. TOTAL RECEIPTS | | <u>-0-</u> | <u>-0-</u> |
| 8. PRODUCTION | | <u>-0-</u> | <u>-0-</u> |
| 9. MATERIAL TO BE ACCOUNTED FOR (Total of lines 5, 7, and 8). | | | |
| 10. SHIPMENTS: | | <u>869,241.74</u> | <u>31,415.89</u> |
| To _____ | Consignee's License No. _____ | | |
| _____ | _____ | | |
| _____ | _____ | | |
| _____ | _____ | | |
| 11. TOTAL SHIPMENTS | | <u>-0-</u> | <u>-0-</u> |
| 12. PROCESSING LOSSES, DISCARDS, ETC.: | | <u>-0-</u> | <u>-0-</u> |
| a. MATERIAL FOR WHICH THE REPORTING LICENSEE IS FINANCIALLY RESPONSIBLE | | | |
| b. MATERIAL FOR WHICH THE REPORTING LICENSEE IS NOT FINANCIALLY RESPONSIBLE | | <u>(.70)</u> | <u>(1.70)</u> |
| 13. BURN-UP | | | |
| 14. ENDING INVENTORY <u>4/30/67 Physical Inventory</u> | | <u>869,242.44</u> | <u>31,417.59</u> |
| 15. MATERIAL ACCOUNTED FOR (Total of lines 11, 12a, 12b, 13 and 14). | | | |
| 16. DETAIL OF ENDING INVENTORY: | | <u>869,241.74</u> | <u>31,415.89</u> |
| a. MATERIAL ON HAND FOR WHICH REPORTING LICENSEE IS FINANCIALLY RESPONSIBLE TO THE AEC UNDER ABOVE LICENSE. | | | |
| b. MATERIAL ON HAND FOR WHICH SOMEONE OTHER THAN REPORTING LICENSEE IS FINANCIALLY RESPONSIBLE TO THE AEC (Detail below) | | <u>860,635.70</u> | <u>23,400.70</u> |
| Name _____ | License No. _____ | | |
| <u>Westinghouse</u> | <u>C x 11</u> | <u>8,606.74</u> | <u>8,016.89</u> |
| a. NOTE: Someone other than reporting licensee is not financially responsible - Westinghouse is. | | | |
| c. Total of a. and b. | | | |
| 17. MATERIAL IN POSSESSION OF OTHERS FOR WHICH REPORTING LICENSEE IS FINANCIALLY RESPONSIBLE TO THE AEC UNDER ABOVE LICENSE (Detail below) | | <u>869,242.44</u> | <u>31,417.59</u> |
| Name _____ | Possessor's License No. _____ | | |
| <u>Westinghouse</u> | <u>785</u> | <u>48,311.30</u> | <u>1,313.60</u> |
| b. NOTE: Material is not in possession of others in possession of Westinghouse | | | |
| TOTAL | | <u>41</u> | |

COMPOSITION OF ENDING INVENTORY

| FORM OF MATERIAL | ELEMENT | % OF ISOTOPE CONTAINED | ISOTOPE | REMARKS |
|---|-------------------|--------------------------------|------------------|---------|
| 18. COMPOSITION OF ITEM 16a. | | | | |
| 950 Rods | 860,635.70 | 2.729 | 23,400.70 | |
| | | | | |
| | | | | |
| | | | | |
| | | | | |
| TOTAL | 860,635.70 | | 23,400.70 | |
| 19. COMPOSITION OF ITEM 16b. | | | | |
| 40 WER Elements | 8,606.74 | 93.15 | 8,016.89 | |
| | | | | |
| | | | | |
| | | | | |
| | | | | |
| TOTAL | 8,606.74 | | 8,016.89 | |
| 20. TOTAL INVENTORY ON HAND (Total of Items 18 and 19). | | | | |
| | 869,242.44 | | 31,418.59 | |
| 21. COMPOSITION OF ITEM 17. | | | | |
| Loose Pellets | 48,311.30 | 2.72 | 1,313.60 | |
| | | | | |
| | | | | |
| | | | | |
| | | | | |
| TOTAL | 48,311.30 | | 1,313.60 | |
| 22. TO THE BEST OF MY KNOWLEDGE AND BELIEF THE INFORMATION GIVEN ABOVE AND IN THE ATTACHED SCHEDULES, IF ANY, IS TRUE, COMPLETE, AND CORRECT. | | | | |
| _____ (Date) | | _____ (Signature and Title) | | |

18 U.S.C., SECTION 1001, ACT OF JUNE 25, 1948, 62 STAT. 749, MAKES IT A CRIMINAL OFFENSE TO MAKE A WILLFULLY FALSE STATEMENT OR REPRESENTATION TO ANY DEPARTMENT OR AGENCY OF THE UNITED STATES AS TO ANY MATTER WITHIN ITS JURISDICTION.

MATERIAL STATUS REPORT

FOR SPECIAL NUCLEAR MATERIALS HELD UNDER LICENSE
PREPARE A SEPARATE REPORT FOR EACH LICENSE

| 1. REPORTING LICENSEE: | | 4. TOTAL QUANTITY AND ISOTOPE DATA | |
|--|------------------------------------|------------------------------------|------------|
| a. Name <u>Westinghouse Atomic Power Division</u> | | c. License No. <u>770-277</u> | |
| b. Address <u>Box 355, Pittsburgh, Pa. 15230</u> | | d. Period Ending <u>4/30/67</u> | |
| 2. MATERIAL: (Prepare separate report for each material) | 3. WEIGHT UNIT | a. ELEMENT | b. ISOTOPE |
| 5. BEGINNING INVENTORY: <u>Enriched Uranium</u> <u>Gram</u> <u>January 1, 1967</u> | | 29,856.616 | 1,672.865 |
| 6. RECEIPTS: | | | |
| From <u>Idaho Nuclear</u> | Shipper's License No. <u>JWC</u> | 600.000 | 108.000 |
| 7. TOTAL RECEIPTS | | 600.000 | 108.000 |
| 8. PRODUCTION | | | |
| 9. MATERIAL TO BE ACCOUNTED FOR (Total of lines 5, 7, and 8). | | 30,456.616 | 1,780.865 |
| 10. SHIPMENTS: | | | |
| To <u>Union Carbide Corp.</u> | Consignee's License No. <u>724</u> | 7.496 | 7.035 |
| 11. TOTAL SHIPMENTS | | 7.496 | 7.035 |
| 12. PROCESSING LOSSES, DISCARDS, ETC.: | | | |
| a. MATERIAL FOR WHICH THE REPORTING LICENSEE IS FINANCIALLY RESPONSIBLE | | 1,227.59 | 79.51 |
| b. MATERIAL FOR WHICH THE REPORTING LICENSEE IS NOT FINANCIALLY RESPONSIBLE | | 4.12 | 3.03 |
| 13. BURN-UP | | | |
| 14. ENDING INVENTORY <u>4/30/67 Physical Inventory</u> | | 29,247.41 | 1,690.49 |
| 15. MATERIAL ACCOUNTED FOR (Total of lines 11, 12a, 12b, 13 and 14). | | 30,486.62 | 1,786.87 |
| 16. DETAIL OF ENDING INVENTORY: | | | |
| a. MATERIAL ON HAND FOR WHICH REPORTING LICENSEE IS FINANCIALLY RESPONSIBLE TO THE AEC UNDER ABOVE LICENSE. | | 25,013.41 | 1,568.49 |
| b. MATERIAL ON HAND FOR WHICH SOMEONE OTHER THAN REPORTING LICENSEE IS FINANCIALLY RESPONSIBLE TO THE AEC (Detail below) | | | |
| Name <u>Yankee Atomic</u> | License No. <u>DPR-3</u> | 4,234.00 | 122.00 |
| c. Total of a. and b. | | 29,247.41 | 1,690.49 |
| 17. MATERIAL IN POSSESSION OF OTHERS FOR WHICH REPORTING LICENSEE IS FINANCIALLY RESPONSIBLE TO THE AEC UNDER ABOVE LICENSE (Detail below) | | | |
| Name _____ | Possessor's License No. _____ | | |
| TOTAL | | | |

COMPOSITION OF ENDING INVENTORY

| FORM OF MATERIAL | ELEMENT | % OF ISOTOPE CONTAINED | ISOTOPE | REMARKS |
|--|---------|------------------------|---------|---------|
| 18. COMPOSITION OF ITEM 16a. | | | | |
| | | | | |
| | | | | |
| | | | | |
| | | | | |
| | | | | |
| | | | | |
| | | | | |
| TOTAL | | | | |
| 19. COMPOSITION OF ITEM 16b. | | | | |
| | | | | |
| | | | | |
| | | | | |
| | | | | |
| | | | | |
| | | | | |
| | | | | |
| TOTAL | | | | |
| 20. TOTAL INVENTORY ON HAND <i>(Total of Items 18 and 19).</i> | | SEE ATTACHED | | |
| 21. COMPOSITION OF ITEM 17. | | | | |
| | | | | |
| | | | | |
| | | | | |
| | | | | |
| | | | | |
| | | | | |
| | | | | |
| TOTAL | | | | |
| 22. TO THE BEST OF MY KNOWLEDGE AND BELIEF THE INFORMATION GIVEN ABOVE AND IN THE ATTACHED SCHEDULES, IF ANY, IS TRUE, COMPLETE, AND CORRECT. <div style="display: flex; justify-content: space-between;"> _____ (Date) _____ (Signature and Title) </div> | | | | |

18 U.S.C., SECTION 1001, ACT OF JUNE 25, 1948; 62 STAT. 749, MAKES IT A CRIMINAL OFFENSE TO MAKE A WILLFULLY FALSE STATEMENT OR REPRESENTATION TO ANY DEPARTMENT OR AGENCY OF THE UNITED STATES AS TO ANY MATTER WITHIN ITS JURISDICTION.

672-500 U.S. GOVERNMENT PRINTING OFFICE: 1961 OF-000049

| <u>Form of Material</u> | <u>Element</u> | <u>% of Isotope Contained</u> | <u>Isotope</u> | <u>Remarks</u> |
|---|----------------|-------------------------------|---------------------------------|----------------|
| 18. <u>Composition of Item 16a.</u> | | | | |
| | 4 | 97.65 | 4 | |
| | 21,267.41 | 6.75 | 1,436.49 | |
| | 345 | 9.85 | 34 | |
| | 1,613 | .85 | 13 | |
| | 671 | 5.69 | 38 | |
| | 46 | 2.87 | 1 | |
| | 45 | 3.13 | 1 | |
| | 44 | 3.90 | 2 | |
| | 50 | 5.74 | 3 | |
| | 51 | 2.96 | 2 | |
| | 51 | 3.36 | 2 | |
| | 50 | 3.76 | 2 | |
| | 49 | 4.00 | 2 | |
| | 44 | 3.40 | 1 | |
| | 48 | 4.96 | 2 | |
| | 50 | 3.16 | 2 | |
| | 51 | 3.40 | 2 | |
| | 49 | 3.86 | 2 | |
| | 49 | 3.02 | 1 | |
| | 49 | 3.23 | 2 | |
| | 49 | 3.67 | 2 | |
| | 157 | 3.77 | 6 | |
| | 171 | 4.72 | 8 | |
| | 25,013.41 | | 1,568.49 | |
| 19. <u>Composition of Item 16b</u> | | | | |
| | 4,234.00 | 2.87 | 122.00 | |
| 20. <u>Total Inventory On hand</u> <u>(Total of Items 18 & 19)</u> | | | | |
| | TOTAL | 29,247.41 | 1,690.49 1,568.49 | |

Revenue

Income

of Months
Continued

Element

Form of Payment

1. Description of Item

| | | | |
|-----|-------|-----|-----|
| 1 | 20.70 | 1 | 1 |
| 2 | 27.0 | 2 | 2 |
| 3 | 29.2 | 3 | 3 |
| 4 | 28. | 4 | 4 |
| 5 | 2.69 | 5 | 5 |
| 6 | 2.87 | 6 | 6 |
| 7 | 3.12 | 7 | 7 |
| 8 | 3.20 | 8 | 8 |
| 9 | 2.74 | 9 | 9 |
| 10 | 2.76 | 10 | 10 |
| 11 | 2.36 | 11 | 11 |
| 12 | 2.72 | 12 | 12 |
| 13 | 4.00 | 13 | 13 |
| 14 | 3.40 | 14 | 14 |
| 15 | 4.26 | 15 | 15 |
| 16 | 3.72 | 16 | 16 |
| 17 | 3.40 | 17 | 17 |
| 18 | 3.40 | 18 | 18 |
| 19 | 3.40 | 19 | 19 |
| 20 | 3.40 | 20 | 20 |
| 21 | 3.40 | 21 | 21 |
| 22 | 3.40 | 22 | 22 |
| 23 | 3.40 | 23 | 23 |
| 24 | 3.40 | 24 | 24 |
| 25 | 3.40 | 25 | 25 |
| 26 | 3.40 | 26 | 26 |
| 27 | 3.40 | 27 | 27 |
| 28 | 3.40 | 28 | 28 |
| 29 | 3.40 | 29 | 29 |
| 30 | 3.40 | 30 | 30 |
| 31 | 3.40 | 31 | 31 |
| 32 | 3.40 | 32 | 32 |
| 33 | 3.40 | 33 | 33 |
| 34 | 3.40 | 34 | 34 |
| 35 | 3.40 | 35 | 35 |
| 36 | 3.40 | 36 | 36 |
| 37 | 3.40 | 37 | 37 |
| 38 | 3.40 | 38 | 38 |
| 39 | 3.40 | 39 | 39 |
| 40 | 3.40 | 40 | 40 |
| 41 | 3.40 | 41 | 41 |
| 42 | 3.40 | 42 | 42 |
| 43 | 3.40 | 43 | 43 |
| 44 | 3.40 | 44 | 44 |
| 45 | 3.40 | 45 | 45 |
| 46 | 3.40 | 46 | 46 |
| 47 | 3.40 | 47 | 47 |
| 48 | 3.40 | 48 | 48 |
| 49 | 3.40 | 49 | 49 |
| 50 | 3.40 | 50 | 50 |
| 51 | 3.40 | 51 | 51 |
| 52 | 3.40 | 52 | 52 |
| 53 | 3.40 | 53 | 53 |
| 54 | 3.40 | 54 | 54 |
| 55 | 3.40 | 55 | 55 |
| 56 | 3.40 | 56 | 56 |
| 57 | 3.40 | 57 | 57 |
| 58 | 3.40 | 58 | 58 |
| 59 | 3.40 | 59 | 59 |
| 60 | 3.40 | 60 | 60 |
| 61 | 3.40 | 61 | 61 |
| 62 | 3.40 | 62 | 62 |
| 63 | 3.40 | 63 | 63 |
| 64 | 3.40 | 64 | 64 |
| 65 | 3.40 | 65 | 65 |
| 66 | 3.40 | 66 | 66 |
| 67 | 3.40 | 67 | 67 |
| 68 | 3.40 | 68 | 68 |
| 69 | 3.40 | 69 | 69 |
| 70 | 3.40 | 70 | 70 |
| 71 | 3.40 | 71 | 71 |
| 72 | 3.40 | 72 | 72 |
| 73 | 3.40 | 73 | 73 |
| 74 | 3.40 | 74 | 74 |
| 75 | 3.40 | 75 | 75 |
| 76 | 3.40 | 76 | 76 |
| 77 | 3.40 | 77 | 77 |
| 78 | 3.40 | 78 | 78 |
| 79 | 3.40 | 79 | 79 |
| 80 | 3.40 | 80 | 80 |
| 81 | 3.40 | 81 | 81 |
| 82 | 3.40 | 82 | 82 |
| 83 | 3.40 | 83 | 83 |
| 84 | 3.40 | 84 | 84 |
| 85 | 3.40 | 85 | 85 |
| 86 | 3.40 | 86 | 86 |
| 87 | 3.40 | 87 | 87 |
| 88 | 3.40 | 88 | 88 |
| 89 | 3.40 | 89 | 89 |
| 90 | 3.40 | 90 | 90 |
| 91 | 3.40 | 91 | 91 |
| 92 | 3.40 | 92 | 92 |
| 93 | 3.40 | 93 | 93 |
| 94 | 3.40 | 94 | 94 |
| 95 | 3.40 | 95 | 95 |
| 96 | 3.40 | 96 | 96 |
| 97 | 3.40 | 97 | 97 |
| 98 | 3.40 | 98 | 98 |
| 99 | 3.40 | 99 | 99 |
| 100 | 3.40 | 100 | 100 |

1,000.00

52,013.41

10.00

4,134.00

1,000.00

19,745.00

Total of all items

Total of all items

TOTAL

UNITED STATES ATOMIC ENERGY COMMISSION
MATERIAL STATUS REPORT

FOR SPECIAL NUCLEAR MATERIALS HELD UNDER LICENSE
PREPARE A SEPARATE REPORT FOR EACH LICENSE

| | | | |
|--|---|------------------------------------|-----------------|
| 1. REPORTING LICENSEE: | | | |
| a. Name | <u>Westinghouse Atomic Power Division</u> | c. License No. | <u>785 ZVP</u> |
| b. Address | <u>Box 355, Pittsburgh, Pa. 15230</u> | d. Period Ending | <u>4/30/67</u> |
| 2. MATERIAL: (Prepare separate report for each material) | 3. WEIGHT UNIT | 4. TOTAL QUANTITY AND ISOTOPE DATA | |
| <u>Enriched Uranium</u> | <u>Gram</u> | a. ELEMENT | b. ISOTOPE |
| 5. BEGINNING INVENTORY: | <u>January 1, 1967</u> | <u>48,311.00</u> | <u>1,315.00</u> |
| 6. RECEIPTS: | | | |
| From | Shipper's License No. | | |
| | | | |
| | | | |
| | | | |
| 7. TOTAL RECEIPTS | | <u>0</u> | <u>0</u> |
| 8. PRODUCTION | | | |
| 9. MATERIAL TO BE ACCOUNTED FOR (Total of lines 5, 7, and 8). | | <u>48,311.00</u> | <u>1,315.00</u> |
| 10. SHIPMENTS: | | | |
| To | Consignee's License No. | | |
| | | | |
| | | | |
| | | | |
| 11. TOTAL SHIPMENTS | | <u>0</u> | <u>0</u> |
| 12. PROCESSING LOSSES, DISCARDS, ETC.: | | | |
| a. MATERIAL FOR WHICH THE REPORTING LICENSEE IS FINANCIALLY RESPONSIBLE | | | |
| b. MATERIAL FOR WHICH THE REPORTING LICENSEE IS NOT FINANCIALLY RESPONSIBLE | | <u>(.30)</u> | <u>1.40</u> |
| 13. BURN-UP | | | |
| 14. ENDING INVENTORY <u>4/30/67 Physical Inventory</u> | | <u>48,311.30</u> | <u>1,313.60</u> |
| 15. MATERIAL ACCOUNTED FOR (Total of lines 11, 12a, 12b, 13 and 14). | | <u>48,311.00</u> | <u>1,315.00</u> |
| 16. DETAIL OF ENDING INVENTORY: | | | |
| a. MATERIAL ON HAND FOR WHICH REPORTING LICENSEE IS FINANCIALLY RESPONSIBLE TO THE AEC UNDER ABOVE LICENSE. | | | |
| b. MATERIAL ON HAND FOR WHICH SOMEONE OTHER THAN REPORTING LICENSEE IS FINANCIALLY RESPONSIBLE TO THE AEC (Detail below) | | | |
| Name | License No. | | |
| <u>*Westinghouse</u> | <u>783</u> | <u>48,311.30</u> | <u>1,313.60</u> |
| | | | |
| | | | |
| c. Total of a. and b. | | <u>48,311.30</u> | <u>1,313.60</u> |
| 17. MATERIAL IN POSSESSION OF OTHERS FOR WHICH REPORTING LICENSEE IS FINANCIALLY RESPONSIBLE TO THE AEC UNDER ABOVE LICENSE (Detail below) | | | |
| Name | Possessor's License No. | | |
| | | | |
| | | | |
| | | | |
| TOTAL | | | |

*See comments under Lic. No. 783.

COMPOSITION OF ENDING INVENTORY

| FORM OF MATERIAL | ELEMENT | % OF ISOTOPE CONTAINED | ISOTOPE | REMARKS |
|--|-----------|------------------------|----------|---------|
| 18. COMPOSITION OF ITEM 16a. | | | | |
| | | | | |
| | | | | |
| | | | | |
| | | | | |
| | | | | |
| | | | | |
| TOTAL | | | | |
| 19. COMPOSITION OF ITEM 16b. | | | | |
| Loose Pellets | 48,311.30 | 3.72 | 1,313.60 | |
| | | | | |
| | | | | |
| | | | | |
| | | | | |
| TOTAL | 48,311.30 | | 1,313.60 | |
| 20. TOTAL INVENTORY ON HAND (Total of Items 18 and 19). | | | | |
| 21. COMPOSITION OF ITEM 17. | | | | |
| | | | | |
| | | | | |
| | | | | |
| | | | | |
| | | | | |
| | | | | |
| TOTAL | | | | |
| 22. TO THE BEST OF MY KNOWLEDGE AND BELIEF THE INFORMATION GIVEN ABOVE AND IN THE ATTACHED SCHEDULES, IF ANY, IS TRUE, COMPLETE, AND CORRECT. | | | | |
| (Date) | | (Signature and Title) | | |

18 U.S.C., SECTION 1001; ACT OF JUNE 25, 1948; 62 STAT. 749; MAKES IT A CRIMINAL OFFENSE TO MAKE A WILLFULLY FALSE STATEMENT OR REPRESENTATION TO ANY DEPARTMENT OR AGENCY OF THE UNITED STATES AS TO ANY MATTER WITHIN ITS JURISDICTION.

MATERIAL STATUS REPORT

FOR SPECIAL NUCLEAR MATERIALS HELD UNDER LICENSE
PREPARE A SEPARATE REPORT FOR EACH LICENSE

| | | | |
|--|-------------------------------|------------------------------------|-------------|
| 1. REPORTING LICENSEE: | | | |
| a. Name <u>Westinghouse Atomic Power Division</u> | | c. License No. <u>730 ZFP</u> | |
| b. Address <u>Box 355, Pittsburgh, Pa. 15230</u> | | d. Period Ending <u>4/30/67</u> | |
| 2. MATERIAL: (Prepare separate report for each material) | 3. WEIGHT UNIT | 4. TOTAL QUANTITY AND ISOTOPE DATA | |
| <u>Enriched Uranium</u> | <u>Gram</u> | a. ELEMENT | b. ISOTOPE |
| 5. BEGINNING INVENTORY: <u>January 1, 1967</u> | | <u>8.65</u> | <u>8.40</u> |
| 6. RECEIPTS: | | | |
| From _____ | Shipper's License No. _____ | | |
| _____ | _____ | | |
| _____ | _____ | | |
| 7. TOTAL RECEIPTS | | <u>0</u> | <u>0</u> |
| 8. PRODUCTION | | | |
| 9. MATERIAL TO BE ACCOUNTED FOR (Total of lines 5, 7, and 8). | | <u>8.65</u> | <u>8.40</u> |
| 10. SHIPMENTS: | | | |
| To _____ | Consignee's License No. _____ | | |
| _____ | _____ | | |
| _____ | _____ | | |
| 11. TOTAL SHIPMENTS | | <u>0</u> | <u>0</u> |
| 12. PROCESSING LOSSES, DISCARDS, ETC.: | | | |
| a. MATERIAL FOR WHICH THE REPORTING LICENSEE IS FINANCIALLY RESPONSIBLE | | | |
| b. MATERIAL FOR WHICH THE REPORTING LICENSEE IS NOT FINANCIALLY RESPONSIBLE | | | <u>1.00</u> |
| 13. BURN-UP | | | |
| 14. ENDING INVENTORY <u>4/30/67 Physical Inventory</u> | | <u>8.65</u> | <u>7.40</u> |
| 15. MATERIAL ACCOUNTED FOR (Total of lines 11, 12a, 12b, 13 and 14). | | <u>8.65</u> | <u>8.40</u> |
| 16. DETAIL OF ENDING INVENTORY: | | | |
| a. MATERIAL ON HAND FOR WHICH REPORTING LICENSEE IS FINANCIALLY RESPONSIBLE TO THE AEC UNDER ABOVE LICENSE. | | <u>8.65</u> | <u>7.40</u> |
| b. MATERIAL ON HAND FOR WHICH SOMEONE OTHER THAN REPORTING LICENSEE IS FINANCIALLY RESPONSIBLE TO THE AEC (Detail below) | | | |
| Name _____ | License No. _____ | | |
| _____ | _____ | | |
| _____ | _____ | | |
| _____ | _____ | | |
| c. Total of a. and b. | | <u>8.65</u> | <u>7.40</u> |
| 17. MATERIAL IN POSSESSION OF OTHERS FOR WHICH REPORTING LICENSEE IS FINANCIALLY RESPONSIBLE TO THE AEC UNDER ABOVE LICENSE (Detail below) | | | |
| Name _____ | Possessor's License No. _____ | | |
| _____ | _____ | | |
| _____ | _____ | | |
| _____ | _____ | | |
| TOTAL | | | |

COMPOSITION OF ENDING INVENTORY

| FORM OF MATERIAL | ELEMENT | % OF ISOTOPE CONTAINED | ISOTOPE | REMARKS |
|--|-------------|------------------------|-------------|---------|
| 18. COMPOSITION OF ITEM 16a. | | | | |
| Foils | 5.00 | 93.17 | 4.00 | |
| PG Tube | 1.84 | 93.48 | 1.72 | |
| " | 1.81 | 93.00 | 1.68 | |
| | | | | |
| | | | | |
| TOTAL | 8.65 | | 7.40 | |
| 19. COMPOSITION OF ITEM 16b. | | | | |
| | | | | |
| | | | | |
| | | | | |
| | | | | |
| | | | | |
| | | | | |
| TOTAL | | | | |
| 20. TOTAL INVENTORY ON HAND <i>(Total of Items 18 and 19).</i> | | | | |
| 21. COMPOSITION OF ITEM 17. | | | | |
| | | | | |
| | | | | |
| | | | | |
| | | | | |
| | | | | |
| | | | | |
| TOTAL | | | | |
| 22. TO THE BEST OF MY KNOWLEDGE AND BELIEF THE INFORMATION GIVEN ABOVE AND IN THE ATTACHED SCHEDULES, IF ANY, IS TRUE, COMPLETE, AND CORRECT. | | | | |
| <div style="display: flex; justify-content: space-between;"> (Date) (Signature and Title) </div> | | | | |

18 U.S.C., SECTION 1001, ACT OF JUNE 25, 1948, 62 STAT. 749, MAKES IT A CRIMINAL OFFENSE TO MAKE A WILLFULLY FALSE STATEMENT OR REPRESENTATION TO ANY DEPARTMENT OR AGENCY OF THE UNITED STATES AS TO ANY MATTER WITHIN ITS JURISDICTION.

UNITED STATES ATOMIC ENERGY COMMISSION
MATERIAL STATUS REPORT
FOR SPECIAL NUCLEAR MATERIALS HELD UNDER LICENSE
PREPARE A SEPARATE REPORT FOR EACH LICENSE

| | | | |
|--|-------------------------------|------------------------------------|--------------|
| 1. REPORTING LICENSEE: | | | |
| a. Name <u>Westinghouse Atomic Power Division</u> | | c. License No. <u>38 ZYP</u> | |
| b. Address <u>Box 355, Pittsburgh, Pa. 15230</u> | | d. Period Ending <u>4/30/67</u> | |
| 2. MATERIAL: (Prepare separate report for each material) | 3. WEIGHT UNIT | 4. TOTAL QUANTITY AND ISOTOPE DATA | |
| <u>Enriched Uranium</u> | <u>Gram</u> | a. ELEMENT | b. ISOTOPE |
| 5. BEGINNING INVENTORY: <u>January 1, 1967</u> | | <u>44.00</u> | <u>10.79</u> |
| 6. RECEIPTS: | | | |
| From _____ | Shipper's License No. _____ | | |
| _____ | _____ | | |
| _____ | _____ | | |
| 7. TOTAL RECEIPTS | | <u>0</u> | <u>0</u> |
| 8. PRODUCTION | | | |
| 9. MATERIAL TO BE ACCOUNTED FOR (Total of lines 5, 7, and 8). | | <u>44.00</u> | <u>10.79</u> |
| 10. SHIPMENTS: | | | |
| To _____ | Consignee's License No. _____ | | |
| _____ | _____ | | |
| _____ | _____ | | |
| 11. TOTAL SHIPMENTS | | <u>0</u> | <u>0</u> |
| 12. PROCESSING LOSSES, DISCARDS, ETC.: | | | |
| a. MATERIAL FOR WHICH THE REPORTING LICENSEE IS FINANCIALLY RESPONSIBLE | | | |
| b. MATERIAL FOR WHICH THE REPORTING LICENSEE IS NOT FINANCIALLY RESPONSIBLE | | | |
| 13. BURN-UP | | | |
| 14. ENDING INVENTORY <u>4/30/67 Physical Inventory</u> | | <u>44.00</u> | <u>10.79</u> |
| 15. MATERIAL ACCOUNTED FOR (Total of lines 11, 12a, 12b, 13 and 14). | | | |
| 16. DETAIL OF ENDING INVENTORY: | | <u>44.00</u> | <u>10.79</u> |
| a. MATERIAL ON HAND FOR WHICH REPORTING LICENSEE IS FINANCIALLY RESPONSIBLE TO THE AEC UNDER ABOVE LICENSE. | | | |
| b. MATERIAL ON HAND FOR WHICH SOMEONE OTHER THAN REPORTING LICENSEE IS FINANCIALLY RESPONSIBLE TO THE AEC (Detail below) | | <u>44.00</u> | <u>10.79</u> |
| Name _____ | License No. _____ | | |
| _____ | _____ | | |
| _____ | _____ | | |
| c. Total of a. and b. | | <u>44.00</u> | <u>10.79</u> |
| 17. MATERIAL IN POSSESSION OF OTHERS FOR WHICH REPORTING LICENSEE IS FINANCIALLY RESPONSIBLE TO THE AEC UNDER ABOVE LICENSE (Detail below) | | <u>44.00</u> | <u>10.79</u> |
| Name _____ | Possessor's License No. _____ | | |
| _____ | _____ | | |
| _____ | _____ | | |
| TOTAL | | | |

COMPOSITION OF ENDING INVENTORY

| FORM OF MATERIAL | ELEMENT | % OF ISOTOPE CONTAINED | ISOTOPE | REMARKS |
|---|---------|------------------------|---------|---------|
| 18. COMPOSITION OF ITEM 16a. | | | | |
| UZR Sheet | 3.00 | 93.00 | 2.79 | |
| Pellets | 41.00 | 18.64 | 8.00 | |
| | | | | |
| | | | | |
| | | | | |
| TOTAL | 44.00 | | 10.79 | |
| 19. COMPOSITION OF ITEM 16b. | | | | |
| | | | | |
| | | | | |
| | | | | |
| | | | | |
| | | | | |
| TOTAL | | | | |
| 20. TOTAL INVENTORY ON HAND (Total of Items 18 and 19). | | | | |
| 21. COMPOSITION OF ITEM 17. | | | | |
| See December 31, 1966 Material Status Report | | | | |
| | | | | |
| | | | | |
| | | | | |
| | | | | |
| TOTAL | | | | |
| <p>22. TO THE BEST OF MY KNOWLEDGE AND BELIEF THE INFORMATION GIVEN ABOVE AND IN THE ATTACHED SCHEDULES, IF ANY, IS TRUE, COMPLETE, AND CORRECT.</p> <p>_____</p> <p style="display: flex; justify-content: space-between;"> (Date) (Signature and Title) </p> | | | | |

18 U.S.C., SECTION 1001; ACT OF JUNE 25, 1948, 62 STAT. 749; MAKES IT A CRIMINAL OFFENSE TO MAKE A WILLFULLY FALSE STATEMENT OR REPRESENTATION TO ANY DEPARTMENT OR AGENCY OF THE UNITED STATES AS TO ANY MATTER WITHIN ITS JURISDICTION.

MATERIAL STATUS REPORT

FOR SPECIAL NUCLEAR MATERIALS HELD UNDER LICENSE
PREPARE A SEPARATE REPORT FOR EACH LICENSE

| | | | |
|--|---|------------------------------------|------------------|
| 1. REPORTING LICENSEE: | | | |
| a. Name | <u>Westinghouse Atomic Power Division</u> | c. License No. | <u>CX 11 ZYP</u> |
| b. Address | <u>Box 355, Pittsburgh, Pa. 15230</u> | d. Period Ending | <u>4/30/67</u> |
| 2. MATERIAL: (Prepare separate report for each material) | 3. WEIGHT UNIT | 4. TOTAL QUANTITY AND ISOTOPE DATA | |
| <u>Enriched Uranium</u> | <u>Gram</u> | a. ELEMENT | b. ISOTOPE |
| 5. BEGINNING INVENTORY: | <u>January 1, 1967</u> | <u>-0-</u> | <u>-0-</u> |
| 6. RECEIPTS: | | | |
| From | Shipper's License No. | | |
| | | | |
| | | | |
| | | | |
| 7. TOTAL RECEIPTS | | <u>-0-</u> | <u>-0-</u> |
| 8. PRODUCTION | | | |
| 9. MATERIAL TO BE ACCOUNTED FOR (Total of lines 5, 7, and 8). | | | |
| 10. SHIPMENTS: | | | |
| To | Consignee's License No. | | |
| | | | |
| | | | |
| | | | |
| 11. TOTAL SHIPMENTS | | <u>-0-</u> | <u>-0-</u> |
| 12. PROCESSING LOSSES, DISCARDS, ETC.: | | | |
| a. MATERIAL FOR WHICH THE REPORTING LICENSEE IS FINANCIALLY RESPONSIBLE | | | |
| b. MATERIAL FOR WHICH THE REPORTING LICENSEE IS NOT FINANCIALLY RESPONSIBLE | | | |
| 13. BURN-UP | | | |
| 14. ENDING INVENTORY <u>4/30/67 Physical Inventory</u> | | <u>-0-</u> | <u>-0-</u> |
| 15. MATERIAL ACCOUNTED FOR (Total of lines 11, 12a, 12b, 13 and 14). | | | |
| 16. DETAIL OF ENDING INVENTORY: | | | |
| a. MATERIAL ON HAND FOR WHICH REPORTING LICENSEE IS FINANCIALLY RESPONSIBLE TO THE AEC UNDER ABOVE LICENSE. | | | |
| b. MATERIAL ON HAND FOR WHICH SOMEONE OTHER THAN REPORTING LICENSEE IS FINANCIALLY RESPONSIBLE TO THE AEC (Detail below) | | | |
| Name | License No. | | |
| | | | |
| | | | |
| | | | |
| c. Total of a. and b. | | | |
| 17. MATERIAL IN POSSESSION OF OTHERS FOR WHICH REPORTING LICENSEE IS FINANCIALLY RESPONSIBLE TO THE AEC UNDER ABOVE LICENSE (Detail below) | | | |
| Name | Possessor's License No. | | |
| <u>*Westinghouse</u> | <u>783</u> | <u>8606.74</u> | <u>8016.89</u> |
| | | | |
| | | | |
| TOTAL | | 8606.74 | 8016.89 |

*See 10 CFR 700.5 for comments

COMPOSITION OF ENDING INVENTORY

| FORM OF MATERIAL | ELEMENT | % OF ISOTOPE CONTAINED | ISOTOPE | REMARKS |
|--|---------|--------------------------------|---------|---------|
| 18. COMPOSITION OF ITEM 16a. | | | | |
| | | | | |
| | | | | |
| | | | | |
| | | | | |
| | | | | |
| | | | | |
| TOTAL | | | | |
| 19. COMPOSITION OF ITEM 16b. | | | | |
| | | | | |
| | | | | |
| | | | | |
| | | | | |
| | | | | |
| | | | | |
| TOTAL | | | | |
| 20. TOTAL INVENTORY ON HAND (Total of Items 18 and 19). | | | | |
| 21. COMPOSITION OF ITEM 17. | | | | |
| 40 WTR Elements | 8606.74 | 93.15 | 8016.89 | |
| | | | | |
| | | | | |
| | | | | |
| | | | | |
| TOTAL | 8606.74 | | 8016.89 | |
| 22. TO THE BEST OF MY KNOWLEDGE AND BELIEF THE INFORMATION GIVEN ABOVE AND IN THE ATTACHED SCHEDULES, IF ANY, IS TRUE, COMPLETE, AND CORRECT. | | | | |
| _____ (Date) | | _____ (Signature and Title) | | |

18 U.S.C., SECTION 1001, ACT OF JUNE 25, 1948; 62 STAT. 749; MAKES IT A CRIMINAL OFFENSE TO MAKE A WILLFULLY FALSE STATEMENT OR REPRESENTATION TO ANY DEPARTMENT OR AGENCY OF THE UNITED STATES AS TO ANY MATTER WITHIN ITS JURISDICTION.

UNITED STATES ATOMIC ENERGY COMMISSION
MATERIAL STATUS REPORT
FOR SPECIAL NUCLEAR MATERIALS HELD UNDER LICENSE
PREPARE A SEPARATE REPORT FOR EACH LICENSE

| | | | |
|---|-------------------------------|------------------------------------|---------------|
| 1. REPORTING LICENSEE: | | | |
| a. Name <u>Westinghouse Atomic Power Division</u> | | c. License No. <u>770 EIM</u> | |
| b. Address <u>Box 355, Pittsburgh, Pa. 15230</u> | | d. Period Ending <u>4/30/67</u> | |
| 2. MATERIAL: <i>(Prepare separate report for each material)</i> | 3. WEIGHT UNIT | 4. TOTAL QUANTITY AND ISOTOPE DATA | |
| <u>Plutonium 239 and 241</u> | <u>Gram</u> | a. ELEMENT | b. ISOTOPE |
| 5. BEGINNING INVENTORY: <u>January 1, 1967</u> | | <u>222.67</u> | <u>202.82</u> |
| 6. RECEIPTS: | | | |
| From _____ | Shipper's License No. _____ | | |
| _____ | _____ | | |
| _____ | _____ | | |
| _____ | _____ | | |
| 7. TOTAL RECEIPTS | | <u>0</u> | <u>0</u> |
| 8. PRODUCTION | | | |
| 9. MATERIAL TO BE ACCOUNTED FOR <i>(Total of lines 5, 7, and 8).</i> | | <u>222.67</u> | <u>202.82</u> |
| 10. SHIPMENTS: | | | |
| To _____ | Consignee's License No. _____ | | |
| _____ | _____ | | |
| _____ | _____ | | |
| 11. TOTAL SHIPMENTS | | <u>0</u> | <u>0</u> |
| 12. PROCESSING LOSSES, DISCARDS, ETC.: | | | |
| a. MATERIAL FOR WHICH THE REPORTING LICENSEE IS FINANCIALLY RESPONSIBLE | | | |
| b. MATERIAL FOR WHICH THE REPORTING LICENSEE IS NOT FINANCIALLY RESPONSIBLE | | | |
| 13. BURN-UP | | | |
| 14. ENDING INVENTORY <u>4/30/67 Physical Inventory</u> | | <u>222.67</u> | <u>202.82</u> |
| 15. MATERIAL ACCOUNTED FOR <i>(Total of lines 11, 12a, 12b, 13 and 14).</i> | | <u>222.67</u> | <u>202.82</u> |
| 16. DETAIL OF ENDING INVENTORY: | | | |
| a. MATERIAL ON HAND FOR WHICH REPORTING LICENSEE IS FINANCIALLY RESPONSIBLE TO THE AEC UNDER ABOVE LICENSE. | | <u>222.67</u> | <u>202.82</u> |
| b. MATERIAL ON HAND FOR WHICH SOMEONE OTHER THAN REPORTING LICENSEE IS FINANCIALLY RESPONSIBLE TO THE AEC <i>(Detail below)</i> | | | |
| Name _____ | License No. _____ | | |
| _____ | _____ | | |
| _____ | _____ | | |
| _____ | _____ | | |
| c. Total of a. and b. | | <u>222.67</u> | <u>202.82</u> |
| 17. MATERIAL IN POSSESSION OF OTHERS FOR WHICH REPORTING LICENSEE IS FINANCIALLY RESPONSIBLE TO THE AEC UNDER ABOVE LICENSE <i>(Detail below)</i> | | | |
| Name _____ | Possessor's License No. _____ | | |
| _____ | _____ | | |
| _____ | _____ | | |
| _____ | _____ | | |
| TOTAL | | | |

COMPOSITION OF ENDING INVENTORY

| FORM OF MATERIAL | ELEMENT | % OF ISOTOPE CONTAINED | ISOTOPE | REMARKS |
|---|---------|------------------------|---------|---------|
| 18. COMPOSITION OF ITEM 16a. | | | | |
| Saxton Pu/II02 Retentions | 23.36 | | 21.09 | |
| Sealed Source M 243 | 79.95 | | 74.37 | |
| A Saxton Pu/II02 Rods | 119.36 | | 107.36 | |
| <hr/> | | | | |
| TOTAL | 222.67 | | 202.82 | |
| 19. COMPOSITION OF ITEM 16b. | | | | |
| <hr/> | | | | |
| <hr/> | | | | |
| <hr/> | | | | |
| <hr/> | | | | |
| <hr/> | | | | |
| <hr/> | | | | |
| <hr/> | | | | |
| <hr/> | | | | |
| <hr/> | | | | |
| <hr/> | | | | |
| <hr/> | | | | |
| <hr/> | | | | |
| <hr/> | | | | |
| <hr/> | | | | |
| <hr/> | | | | |
| <hr/> | | | | |
| 20. TOTAL INVENTORY ON HAND (Total of Items 18 and 19). | | | | |
| <hr/> | | | | |
| 21. COMPOSITION OF ITEM 17. | | | | |
| <hr/> | | | | |
| <hr/> | | | | |
| <hr/> | | | | |
| <hr/> | | | | |
| <hr/> | | | | |
| <hr/> | | | | |
| <hr/> | | | | |
| <hr/> | | | | |
| <hr/> | | | | |
| <hr/> | | | | |
| <hr/> | | | | |
| <hr/> | | | | |
| <hr/> | | | | |
| <hr/> | | | | |
| <hr/> | | | | |
| 22. TO THE BEST OF MY KNOWLEDGE AND BELIEF THE INFORMATION GIVEN ABOVE AND IN THE ATTACHED SCHEDULES, IF ANY, IS TRUE, COMPLETE, AND CORRECT. | | | | |
| | | (Date) | | |
| | | (Signature and Title) | | |

18 U.S.C. SECTION 1001; ACT OF JUNE 25, 1948, 62 STAT. 749; MAKES IT A CRIMINAL OFFENSE TO MAKE A WILLFULLY FALSE STATEMENT OR REPRESENTATION TO ANY DEPARTMENT OR AGENCY OF THE UNITED STATES AS TO ANY MATTER WITHIN ITS JURISDICTION.

MATERIAL STATUS REPORT

FOR SPECIAL NUCLEAR MATERIALS HELD UNDER LICENSE
PREPARE A SEPARATE REPORT FOR EACH LICENSE

| | | | |
|--|-------------------------------|------------------------------------|--------------|
| 1. REPORTING LICENSEE: | | | |
| a. Name <u>Westinghouse Atomic Power Division</u> | | c. License No. <u>730 ZYP</u> | |
| b. Address <u>Box 355, Pittsburgh, Pa. 15230</u> | | d. Period Ending <u>4/30.67</u> | |
| 2. MATERIAL: (Prepare separate report for each material) | 3. WEIGHT, UNIT | 4. TOTAL QUANTITY AND ISOTOPE DATA | |
| | | e. ELEMENT | b. ISOTOPE |
| 5. BEGINNING INVENTORY: <u>Plutonium 239 and 241</u> | <u>Gram</u> | | |
| 6. RECEIPTS: | | <u>63.99</u> | <u>59.53</u> |
| From _____ | Shipper's License No. _____ | | |
| _____ | _____ | | |
| _____ | _____ | | |
| 7. TOTAL RECEIPTS | | <u>0</u> | <u>0</u> |
| 8. PRODUCTION | | | |
| 9. MATERIAL TO BE ACCOUNTED FOR (Total of lines 5, 7, and 8). | | <u>63.99</u> | <u>59.53</u> |
| 10. SHIPMENTS: | | | |
| To _____ | Consignee's License No. _____ | | |
| _____ | _____ | | |
| _____ | _____ | | |
| 11. TOTAL SHIPMENTS | | <u>0</u> | <u>0</u> |
| 12. PROCESSING LOSSES, DISCARDS, ETC.: | | | |
| a. MATERIAL FOR WHICH THE REPORTING LICENSEE IS FINANCIALLY RESPONSIBLE | | | |
| b. MATERIAL FOR WHICH THE REPORTING LICENSEE IS NOT FINANCIALLY RESPONSIBLE | | | |
| 13. BURN-UP | | | |
| 14. ENDING INVENTORY <u>4/30/67 Physical Inventory</u> | | <u>63.99</u> | <u>59.53</u> |
| 15. MATERIAL ACCOUNTED FOR (Total of lines 11, 12a, 12b, 13 and 14). | | | |
| 16. DETAIL OF ENDING INVENTORY: | | <u>63.99</u> | <u>59.53</u> |
| a. MATERIAL ON HAND FOR WHICH REPORTING LICENSEE IS FINANCIALLY RESPONSIBLE TO THE AEC UNDER ABOVE LICENSE. | | | |
| b. MATERIAL ON HAND FOR WHICH SOMEONE OTHER THAN REPORTING LICENSEE IS FINANCIALLY RESPONSIBLE TO THE AEC (Detail below) | | <u>63.99</u> | <u>59.53</u> |
| Name _____ | License No. _____ | | |
| _____ | _____ | | |
| _____ | _____ | | |
| c. Total of a. and b. | | | |
| 17. MATERIAL IN POSSESSION OF OTHERS FOR WHICH REPORTING LICENSEE IS FINANCIALLY RESPONSIBLE TO THE AEC UNDER ABOVE LICENSE (Detail below) | | <u>63.99</u> | <u>59.53</u> |
| Name _____ | Possessor's License No. _____ | | |
| _____ | _____ | | |
| _____ | _____ | | |
| TOTAL | | | |

COMPOSITION OF ENDING INVENTORY

| FORM OF MATERIAL | ELEMENT | % OF ISOTOPE CONTAINED | ISOTOPE | REMARKS |
|---|--------------|------------------------|--------------|---------|
| 18. COMPOSITION OF ITEM 16a. | | | | |
| Source N 979 | 32.00 | | 29.77 | |
| N 67 | 16.01 | | 14.89 | |
| N 691 | 15.98 | | 14.87 | |
| | | | | |
| | | | | |
| TOTAL | 63.99 | | 59.53 | |
| 19. COMPOSITION OF ITEM 16b. | | | | |
| | | | | |
| | | | | |
| | | | | |
| | | | | |
| | | | | |
| | | | | |
| TOTAL | | | | |
| 20. TOTAL INVENTORY ON HAND (Total of Items 18 and 19). | | | | |
| 21. COMPOSITION OF ITEM 17. | | | | |
| | | | | |
| | | | | |
| | | | | |
| | | | | |
| | | | | |
| | | | | |
| TOTAL | | | | |
| <p>22. TO THE BEST OF MY KNOWLEDGE AND BELIEF THE INFORMATION GIVEN ABOVE AND IN THE ATTACHED SCHEDULES, IF ANY, IS TRUE, COMPLETE, AND CORRECT.</p> <p>_____</p> <p style="display: flex; justify-content: space-between;"> (Date) (Signature and Title) </p> | | | | |

18 U.S.C., SECTION 1001, ACT OF JUNE 25, 1948, 62 STAT. 749; MAKES IT A CRIMINAL OFFENSE TO MAKE A WILLFULLY FALSE STATEMENT OR REPRESENTATION TO ANY DEPARTMENT OR AGENCY OF THE UNITED STATES AS TO ANY MATTER WITHIN ITS JURISDICTION.

UNITED STATES ATOMIC ENERGY COMMISSION
MATERIAL STATUS REPORT
FOR SPECIAL NUCLEAR MATERIALS HELD UNDER LICENSE
PREPARE A SEPARATE REPORT FOR EACH LICENSE

| | | | |
|--|---|------------------------------------|------------------|
| 1. REPORTING LICENSEE: | | | |
| a. Name | <u>Westinghouse Atomic Power Division</u> | c. License No. | <u>783 272</u> |
| b. Address | <u>Box 355, Pittsburgh, Pa. 15230</u> | d. Period Ending | <u>4/30/67</u> |
| 2. MATERIAL: (Prepare separate report for each material) | 3. WEIGHT UNIT | 4. TOTAL QUANTITY AND ISOTOPE DATA | |
| <u>Plutonium 239 and 241</u> | <u>Gram</u> | a. ELEMENT | b. ISOTOPE |
| 5. BEGINNING INVENTORY: | <u>January 1, 1967</u> | <u>0</u> | <u>0</u> |
| 6. RECEIPTS: | | | |
| From | Shipper's License No. | | |
| | | | |
| | | | |
| | | | |
| 7. TOTAL RECEIPTS | | <u>0</u> | <u>0</u> |
| 8. PRODUCTION | | | |
| 9. MATERIAL TO BE ACCOUNTED FOR (Total of lines 5, 7, and 8). | | | |
| 10. SHIPMENTS: | | | |
| To | Consignee's License No. | | |
| | | | |
| | | | |
| | | | |
| 11. TOTAL SHIPMENTS | | | |
| 12. PROCESSING LOSSES, DISCARDS, ETC.: | | | |
| a. MATERIAL FOR WHICH THE REPORTING LICENSEE IS FINANCIALLY RESPONSIBLE | | | |
| b. MATERIAL FOR WHICH THE REPORTING LICENSEE IS NOT FINANCIALLY RESPONSIBLE | | | |
| 13. BURN-UP | | | |
| 14. ENDING INVENTORY | <u>4/30/67 Physical Inventory</u> | <u>0</u> | <u>0</u> |
| 15. MATERIAL ACCOUNTED FOR (Total of lines 11, 12a, 12b, 13 and 14). | | | |
| 16. DETAIL OF ENDING INVENTORY: | | | |
| a. MATERIAL ON HAND FOR WHICH REPORTING LICENSEE IS FINANCIALLY RESPONSIBLE TO THE AEC UNDER ABOVE LICENSE. | | | |
| b. MATERIAL ON HAND FOR WHICH SOMEONE OTHER THAN REPORTING LICENSEE IS FINANCIALLY RESPONSIBLE TO THE AEC (Detail below) | | | |
| Name | License No. | | |
| | | | |
| | | | |
| | | | |
| c. Total of a. and b. | | | |
| 17. MATERIAL IN POSSESSION OF OTHERS FOR WHICH REPORTING LICENSEE IS FINANCIALLY RESPONSIBLE TO THE AEC UNDER ABOVE LICENSE (Detail below) | | | |
| Name | Possessor's License No. | | |
| <u>Saxon Nuclear</u> | <u>ITPR 4</u> | <u>18,386.63</u> | <u>15,923.78</u> |
| <u>Westinghouse</u> | <u>328</u> | <u>1,608.11</u> | <u>1,469.27</u> |
| | | | |
| TOTAL | | | |

*See 14c, No. 783 for comments

COMPOSITION OF ENDING INVENTORY

| FORM OF MATERIAL | ELEMENT | % OF ISOTOPE CONTAINED | ISOTOPE | REMARKS |
|--|------------------|------------------------|-----------------|---------|
| 18. COMPOSITION OF ITEM 16a. | | | | |
| | | | | |
| | | | | |
| | | | | |
| | | | | |
| | | | | |
| | | | | |
| TOTAL | | | | |
| 19. COMPOSITION OF ITEM 16b. | | | | |
| | | | | |
| | | | | |
| | | | | |
| | | | | |
| | | | | |
| | | | | |
| TOTAL | | | | |
| 20. TOTAL INVENTORY ON HAND (Total of Items 18 and 19). | | | | |
| 21. COMPOSITION OF ITEM 17. | | | | |
| Irrad. Fuel in SAX DPR A | 18,386.63 | 86.61 | 15923.78 | |
| 51 Spares @ _lc. 338 | 1,608.11 | 91.37 | 1469.27 | |
| | | | | |
| | | | | |
| | | | | |
| TOTAL | 19,994.74 | | 17393.05 | |
| 22. TO THE BEST OF MY KNOWLEDGE AND BELIEF THE INFORMATION GIVEN ABOVE AND IN THE ATTACHED SCHEDULES, IF ANY, IS TRUE, COMPLETE, AND CORRECT. | | | | |
| <div style="display: flex; justify-content: space-between;"> (Date) _____ (Signature and Title) _____ </div> | | | | |

18 U.S.C., SECTION 1001; ACT OF JUNE 25, 1948, 62 STAT. 749; MAKES IT A CRIMINAL OFFENSE TO MAKE A WILLFULLY FALSE STATEMENT OR REPRESENTATION TO ANY DEPARTMENT OR AGENCY OF THE UNITED STATES AS TO ANY MATTER WITHIN ITS JURISDICTION.

UNITED STATES GOVERNMENT

Memorandum

RWD
~~Cx~~ ~~W~~

TO : R. W. Kirkman, Director
Region I, Division of Compliance

FROM : V. J. D'Amico, Assistant Director for Operations
Division of Nuclear Materials Safeguards

SUBJECT: TRANSMITTAL OF SAFEGUARDS INSPECTION REPORTS

DATE: MAY 29 1968

~~W/43~~
~~W/43~~
hp-fil

Sum
338

Attached for your information and retention are the following safeguards inspection reports:

1. Survey No. NY-245 - "Safeguards Review of SS Materials Held at the Cheswick Site of the Westinghouse Atomic Power Divisions"
2. Survey No. NY-244 - "Survey of SS Materials Safeguards Control at Massachusetts Institute of Technology, Cambridge, Massachusetts"
3. Survey No. NY-247 - "Survey of SS Material Safeguards Control at National Bureau of Standards, U.S. Department of Commerce - Gaithersburg, Maryland"
4. Survey No. NY-248 - "Survey of Safeguards Control and Management of SS Materials at Nuclear Materials & Equipment Corporation (NUMEC) - Facility MAN"

Attachments:
As Stated

cc w/o att:
L.D. Low, CO

C/262

ITEM # 262



5010-108

Buy U.S. Savings Bonds Regularly on the Payroll Savings Plan

(12)

SAFEGUARDS REVIEW OF SS MATERIALS HELD AT THE CHESWICK SITE OF THE WESTINGHOUSE ATOMIC POWER DIVISIONS ISE

I. INTRODUCTION

This review covers SS material located at the Cheswick site for the period 12/1/66 through 10/31/67 held under the following accounts with the Commission.

| | <u>U</u> | <u>U-235</u> | <u>Pu</u> |
|----------------------|------------|--------------|-----------|
| <u>SNM-338</u> | 20,031,645 | 864,558 | 1618 |
| Supply Agreement TAS | 24,109 | 4,379 | |

The review did not cover all material held by Westinghouse under New York's responsibility because of the geographic locations of the material and the nature of work performed at the areas. Materials not included in this review, which are held under other leases and under the facility, will be reviewed during April, 1968.

The activities associated with the material reviewed were pelletization of enriched UO₂ powder and manufacturing of fuel assemblies for domestic and foreign power reactors. A small portion of the total inventory was being used for research and development efforts.

II. SCOPE OF REVIEW

This review was performed in accordance with IAD 7402-13; Interim Procedures for Surveys of Licensed Facilities, and as such, covered the following:

- A. An independent test of the physical inventory.
- B. An evaluation of material losses and material unaccounted for.
- C. An evaluation of measurements pertaining to inventory control.
- D. Internal records and accounting procedures.
- E. Internal Control

III. OPINION STATEMENT

It is our opinion that the Material Status Reports prepared as of October 31, 1967 fairly presents the physical inventory. The journals and records reflect the transactions for the period under review. The internal control procedures are adequate for safeguards of SS materials. The material unaccounted for and the process losses for the survey period were reasonable.

IV. RECOMMENDATIONSA. Prior Recommendations

None

B. Current Recommendations

None

V. DISCUSSIONA. Inventory

The inventory was present in four material balance areas:

| | | |
|--------------|---|------------------------|
| MBA-4 | - | Fuel Manufacturing |
| MBA-5 | - | Development Laboratory |
| MBA-6 | - | Plutonium Facility |
| Substation-6 | - | Navy Facility |

More than 90% of the material was located in MBA-4.

MBA-4

The physical inventory in this area consisted of low enriched uranium in the forms of virgin UO₂ powder, UO₂ pellets, single fuel rods, assemblies and scrap pellets. A prior inventory had been taken in accordance with written inventory procedures. An item listing, segregated by internal job, was presented to the survey team. The survey team initially observed each item as it appeared on the inventory sheet. After each item was observed, populations were established for sampling and independent measurement. Inventory verification consisted of the weighings of containers, piece count of single fuel rods, gamma U-235 measurement of UO₂ pellets, UO₂ powder and single fuel rods with the portable gamma spectrometer. The number of samples withdrawn was based on MIL STD 105D at an AQL of 1.5%.

There were fuel assemblies in sealed shipping containers awaiting shipment to the customer. Since considerable effort and cost was required to unbolt the containers, a certification from management as to the contents of these containers was obtained in lieu of observing the contents.

After completion of the inventory tests, all conversion factors were verified and all extensions and job summaries were checked. The results of these tests were acceptable.

MBA-5

Physical inventory in this area consisted of enriched uranium in the form of pellets, powders, fuel pins and sludges. A prior inventory had been taken. The survey team was presented with an item listing showing location of each item, description and internal job. Each item on the inventory sheets was observed. Items having an SS content greater than 100 gms. of uranium were placed in a population for sampling and weight & U-235 measurement. The number of samples withdrawn were as per MIL STD 105D at an AQL of 1.5%. The items checkweighed were acceptable; however, there were significant differences noted in U-235 content. Samples of items which showed significant differences have been forwarded to the New Brunswick Laboratory. The survey team estimates the maximum error in the inventory for the items which were in disagreement to be 800 gms. of U-235.

MBA-6 Plutonium Facility

The plutonium inventory consisted mainly of plutonium uranium fuel rods. Each of the rods was observed; there were no other inventory tests performed.

Substation-6 - Navy Facility

The material held at this MBA was in the form of retainer samples. The inventory was accepted without verification.

B. Losses and Loss Mechanisms and Material Unaccounted For -(MUF)

Material balances for the major jobs that were in the latter part of production stages during the survey period were prepared. The pertinent data appears below. All values are in kilograms of uranium. The MUF for each job was obtained by subtracting the ending inventory process loss and shipments from the throughput. None of these jobs have been completed. Scrap at reprocessors has not yet been returned to the Commission.

The nature of work for each job is similar; UO_2 powder is pressed into pellets and inserted into tubing to form fuel pins; the pins are then assembled. UF_6 conversion and scrap recovery is sub-contracted.

| <u>Job</u> | <u>Enrichment %</u> | <u>Ending Inventory</u> | <u>Throughput</u> | <u>Shipments</u> | <u>Process Loss</u> | <u>MUF</u> | <u>MUF/Throughput x 100</u> |
|------------|---------------------|-------------------------|-------------------|------------------|---------------------|------------|-----------------------------|
| YSEF | 4.94 | 11,014 | 13,245 | 2,197 | 4 | 30 | .23 |
| UEFA | 2.42 | 288 | 8,409 | 8,060 | 1.3 | 60 | .72 |
| UEFA | 2.91 | 1,166 | 7,254 | 5,989 | 1.6 | 97 | 1.34 |
| UEFA | 3.62 | 5,454 | 7,851 | 2,316 | 1.8 | 81 | 1.03 |

The range of MUF/throughput for 18 completed jobs was .08 - 1.22%. Quantities of uranium ranged from 11 - 190 kgs. uranium. The MUFs for the jobs in production are consistent with past experience.

Process losses declared for the survey period were those associated with liquid waste disposal from floor wash water, contaminated clothing disposal and waste disposal. Each of the declared losses was adequately supported; the quantities were reasonable.

C. Measurement Procedures

The analytical measurements are not performed at the Cheswick site; samples of virgin uranium oxide received from converters and product pellets are forwarded to the Waltz Mill site for uranium and U-235 analyses. An evaluation of laboratory procedures and validity of analytical measurements used for material control purposes was performed at the Waltz Mill Site (NY-235) during the period 4/24 - 28/67. The survey team stated that the overall measurement program is suitable for control of SS material. This review will be repeated during the next survey at the Waltz Mill site which is scheduled during April, 1968.

Weight measurements are performed at the Cheswick site. The survey team noted that they were carried out in an acceptable manner.

D. Internal Records and Accounting Procedures

The records and ledgers maintained under SNM-338 and supply agreement TAS are basically the same as those audited during the previous survey (NY-231). The survey team noted two exceptions to acceptable accounting procedures in that there was lack of support for AEC-578 Line 16b (Material on hand for which someone other than the reporting licensee is financially responsible to the Commission) and Line 17, (Material in possession of others for which the reporting licensee is financially responsible to the Commission). The survey team was able to reconstruct Line 16b for the interim 10/31/67 MSA report (SNM-338) but was not able to reconstruct Line 17. The SS representative was advised to establish support for lines 16b and 17 beginning with transactions since July 1, 1967.

It is our opinion that the journals and records reflect the transactions for the period under review. The interim material status reports fairly present the physical inventory as of 10/31/67.

E. Internal Control

Prior to the field review, an internal control questionnaire was forwarded to the SS representative for completion. The survey team reviewed each response with the SS representative and also performed tests to verify the accuracy of the responses. The survey team's findings indicated that effective internal control procedures were being maintained.

The facility has submitted a procedural manual to the Division of Licensing & Regulation for review. Since this office has already forwarded comments concerning the manual, we have omitted comments in this report.

NY Survey No. 231 makes mention of some practices which were to be investigated by Westinghouse's management. Corrective actions have been taken in that non-recoverable wastes generated are now assigned an estimated uranium content and process losses are declared for this material. A technique is being developed to determine the uranium content of this waste by gamma spectrometry. Liquid wastes are measured and process losses are also declared. The overhead ductwork, wherein the survey team indicated that quantities of uranium were contained, was dismantled and the uranium salvaged; 314 kgs. of low enriched was returned to the Commission. The previous survey team questioned the validity of values placed on sludges forwarded to recovery. Management is considering cross-blending sludges and sampling for uranium and U-235 determination.

The survey team noted that less than 1% of the material on hand had estimated SS contents and that efforts were made to remove scrap on a timely basis.

Ira Cohen
Ira Cohen, Team Leader

12/21/67
Date

M. Langsam
M. Langsam, Auditor

12/21/67
Date

P. J. De Lorenzo
P. J. DeLorenzo, Auditor

12/21/67
Date

UNITED STATES ATOMIC ENERGY COMMISSION
MATERIAL STATUS REPORT
 FOR SPECIAL NUCLEAR MATERIALS HELD UNDER LICENSE
 PREPARE A SEPARATE REPORT FOR EACH LICENSE

| | | | |
|--|-------------------------|-------------------------------|--------------------------|
| 1. REPORTING LICENSEE: | | c. License No. _____ | |
| a. Name <u>U.S. FUEL ELEMENTS AND POWER CO.</u> | | d. Period Ending _____ | |
| b. Address <u>1100 ...</u> | | | |
| 2. MATERIAL: (Prepare separate report for each material) | | 3. WEIGHT UNIT | 4. TOTAL QUANTITY AND IS |
| | | <u>GRAMS</u> | a. ELEMENT |
| 5. BEGINNING INVENTORY: | | <u>13,153.31</u> | |
| 6. RECEIPTS: | | | |
| From _____ | | Shipper's License No. _____ | |
| 7. TOTAL RECEIPTS | | <u>33,045.77</u> | |
| 8. PRODUCTION | | | |
| 9. MATERIAL TO BE ACCOUNTED FOR (Total of lines 5, 7, and 8) | | <u>46,216.66</u> | |
| 10. SHIPMENTS: | | | |
| <u>SEE SCHED. VIII 1R 263</u> | | | |
| To _____ | | Consignee's License No. _____ | |
| 11. TOTAL SHIPMENTS | | <u>26,274.26</u> | |
| 12. PROCESSING LOSSES, DISCARDS, ETC.: | | | |
| a. MATERIAL FOR WHICH THE REPORTING LICENSEE IS FINANCIALLY RESPONSIBLE | | | |
| b. MATERIAL FOR WHICH THE REPORTING LICENSEE IS NOT FINANCIALLY RESPONSIBLE | | <u>(127,171)</u> | |
| | | <u>37,116</u> | |
| 13. BURN-UP | | | |
| 14. ENDING INVENTORY (<u>PHYSICAL</u>) <u>10/31/67</u> <u>SEE VIII 14</u> | | <u>20,031.64</u> | |
| 15. MATERIAL ACCOUNTED FOR (Total of lines 11, 12a, 12b, 13 and 14). | | <u>46,216.66</u> | |
| 16. DETAIL OF ENDING INVENTORY: | | | |
| a. MATERIAL ON HAND FOR WHICH REPORTING LICENSEE IS FINANCIALLY RESPONSIBLE TO THE AEC UNDER ABOVE LICENSE. | | <u>7,411.34</u> | |
| b. MATERIAL ON HAND FOR WHICH SOMEONE OTHER THAN REPORTING LICENSEE IS FINANCIALLY RESPONSIBLE TO THE AEC (Detail below) | | | |
| Name | License No. | | |
| <u>...</u> | <u>SNM-28</u> | <u>36,164</u> | |
| <u>...</u> | <u>DPR-3</u> | <u>11,013,987</u> | |
| <u>...</u> | <u>CPPR-14</u> | <u>1,569,879</u> | |
| <u>...</u> | <u>CPPR-13</u> | <u>238</u> | |
| <u>...</u> | <u>DPR-11</u> | <u>66</u> | |
| c. Total of a. and b. | | <u>20,031.64</u> | |
| 17. MATERIAL IN POSSESSION OF OTHERS FOR WHICH REPORTING LICENSEE IS FINANCIALLY RESPONSIBLE TO THE AEC UNDER ABOVE LICENSE (Detail below) | | | |
| Name | Possessor's License No. | | |
| TOTAL | | | |

MATERIAL STATUS REPORT

FOR SPECIAL NUCLEAR MATERIALS HELD UNDER LICENSE
PREPARE A SEPARATE REPORT FOR EACH LICENSE

| | | | |
|--|-------------------------------|------------------------------------|------------|
| 1. REPORTING LICENSEE: | | c. License No. _____ | |
| a. Name _____ | | d. Period Ending _____ | |
| b. Address _____ | | | |
| 2. MATERIAL: (Prepare separate report for each material) | 3. WEIGHT UNIT | 4. TOTAL QUANTITY AND ISOTOPE DATA | |
| | | a. ELEMENT | b. ISOTOPE |
| 5. BEGINNING INVENTORY: 7/1/67 | | 13,153,182 | 403,415 |
| 6. RECEIPTS: | | | |
| From _____ | Shipper's License No. _____ | | |
| _____ | _____ | | |
| _____ | _____ | | |
| 7. TOTAL RECEIPTS | | 33,062,677 | 1,398,125 |
| 8. PRODUCTION | | | |
| 9. MATERIAL TO BE ACCOUNTED FOR (Total of lines 5, 7, and 8) | | 46,216,660 | 1,801,535 |
| 10. SHIPMENTS: | | | |
| To _____ | Consignee's License No. _____ | | |
| SEE TABLE 1A | | | |
| 11. TOTAL SHIPMENTS | | 26,274,360 | 930,075 |
| 12. PROCESSING LOSSES, DISCARDS, ETC.: | | | |
| a. MATERIAL FOR WHICH THE REPORTING LICENSEE IS FINANCIALLY RESPONSIBLE | 2A1N | (42,043) | (2565) |
| b. MATERIAL FOR WHICH THE REPORTING LICENSEE IS NOT FINANCIALLY RESPONSIBLE | | 131,222 | 6679 |
| 13. BURN-UP | | | |
| 14. ENDING INVENTORY 10/31/67 BEFORE PHYSICAL | | 19,853,140 | 857,446 |
| 15. MATERIAL ACCOUNTED FOR (Total of lines 11, 12a, 12b, 13 and 14) | | 46,216,660 | 1,801,535 |
| 16. DETAIL OF ENDING INVENTORY: | | | |
| a. MATERIAL ON HAND FOR WHICH REPORTING LICENSEE IS FINANCIALLY RESPONSIBLE TO THE AEC UNDER ABOVE LICENSE. | | 7,326,212 | 260,430 |
| b. MATERIAL ON HAND FOR WHICH SOMEONE OTHER THAN REPORTING LICENSEE IS FINANCIALLY RESPONSIBLE TO THE AEC (Detail below) | | | |
| Name _____ | License No. _____ | | |
| VANAFEE BROS. ELECTRIC CO. | DPR-3 | 10,961,736 | 541,243 |
| _____ | CPPR-14 | 1,522,450 | 50,410 |
| _____ | SAMI-38 | 36,721 | 5,363 |
| c. Total of a. and b. | | 19,853,140 | 857,446 |
| 17. MATERIAL IN POSSESSION OF OTHERS FOR WHICH REPORTING LICENSEE IS FINANCIALLY RESPONSIBLE TO THE AEC UNDER ABOVE LICENSE (Detail below) | | | |
| Name _____ | Possessor's License No. _____ | | |
| _____ | _____ | | |
| _____ | _____ | | |
| TOTAL | | | |

MATERIAL STATUS REPORT

FOR SPECIAL NUCLEAR MATERIALS HELD UNDER LICENSE
PREPARE A SEPARATE REPORT FOR EACH LICENSE

| 1. REPORTING LICENSEE: | | 4. TOTAL QUANTITY AND ISOTOPE DATA | |
|--|-------------------------|------------------------------------|-------------|
| a. Name <u>WESTINGHOUSE ATOMIC POWER DIV.</u> | | a. ELEMENT | b. ISO |
| b. Address <u>BOX 353 PITTS. PA 15230</u> | | d. Period Ending <u>10/31</u> | |
| c. License No. <u>328</u> | | | |
| 2. MATERIAL: (Prepare separate reports for each material) | | 3. WEIGHT UNIT <u>GRAMS</u> | |
| 5. BEGINNING INVENTORY: <u>JULY 1, 1967</u> | | <u>1451.57</u> | <u>1.37</u> |
| 6. RECEIPTS | | | |
| From | Shipper's License No. | | |
| <u>WESTINGHOUSE</u> | <u>SNM-7</u> | <u>291.95</u> | |
| 7. TOTAL RECEIPTS | | <u>291.95</u> | |
| 8. PRODUCTION | | | |
| 9. MATERIAL TO BE ACCOUNTED FOR (Total of lines 5, 7, and 8). | | <u>1743.47</u> | |
| 10. SHIPMENTS: | | | |
| To | Consignee's License No. | | |
| 11. TOTAL SHIPMENTS | | | |
| 12. PROCESSING LOSSES, DISCARDS, ETC.: | | | |
| a. MATERIAL FOR WHICH THE REPORTING LICENSEE IS FINANCIALLY RESPONSIBLE | | | |
| b. MATERIAL FOR WHICH THE REPORTING LICENSEE IS NOT FINANCIALLY RESPONSIBLE | | <u>125.53</u> | |
| 13. BURN-UP | | | |
| 14. ENDING INVENTORY | | <u>1,617.74</u> | |
| 15. MATERIAL ACCOUNTED FOR (Total of lines 11, 12a, 12b, 13 and 14). | | <u>1743.47</u> | |
| 16. DETAIL OF ENDING INVENTORY: | | | |
| a. MATERIAL ON HAND FOR WHICH REPORTING LICENSEE IS FINANCIALLY RESPONSIBLE TO THE AEC UNDER ABOVE LICENSE. | | | |
| b. MATERIAL ON HAND FOR WHICH SOMEONE OTHER THAN REPORTING LICENSEE IS FINANCIALLY RESPONSIBLE TO THE AEC (Detail below) | | | |
| Name | License No. | | |
| <u>WEST ATOMIC POWER DIV.</u> | <u>783</u> | <u>1,617.74</u> | |
| c. Total of a. and b. | | <u>1,617.74</u> | |
| 17. MATERIAL IN POSSESSION OF OTHERS FOR WHICH REPORTING LICENSEE IS FINANCIALLY RESPONSIBLE TO THE AEC UNDER ABOVE LICENSE (Detail below) | | | |
| Name | Possessor's License No. | | |
| TOTAL | | | |

UNITED STATES ATOMIC ENERGY COMMISSION
 MATERIAL STATUS REPORT
 For Enriched Uranium Held Under a Supply Agreement

1. REPORTING FACILITY:
 a. Name WESTINGHOUSE Atomic Power Div.
 b. Address N.O. Box 355
PITTS. PA. 15230

2. REPORTING IDENTIFICATION SYM.
 3. Report Period: JULY 1
 (From)
 To: OCTOBER 31

4. TOTAL QUANTITY AND ISOTOPE DATA a. Uranium
(Grams)

| | | |
|--|------------|------------------|
| 5. Beginning Inventory . . . <u>7/1/67</u> | | <u>24,053.00</u> |
| 6. RECEIPTS: | <u>RIS</u> | |
| From _____ | _____ | _____ |
| _____ | _____ | _____ |
| _____ | _____ | _____ |
| _____ | _____ | _____ |
| _____ | _____ | _____ |
| _____ | _____ | _____ |
| _____ | _____ | _____ |
| _____ | _____ | _____ |
| 7. TOTAL RECEIPTS | | _____ |
| 8. MATERIAL TO BE ACCOUNTED FOR (Total Lines 5 & 7) | | <u>24,053.00</u> |

| | | |
|-------------------------------|------------|---------------|
| 9. SHIPMENTS: | | |
| To _____ | _____ | _____ |
| <u>(ADJUSTMENT) NUMEC HCC</u> | <u>TBL</u> | <u>385.00</u> |
| _____ | _____ | _____ |
| _____ | _____ | _____ |
| _____ | _____ | _____ |
| _____ | _____ | _____ |
| _____ | _____ | _____ |
| 10. TOTAL SHIPMENTS | | <u>385.00</u> |

| | | |
|--|-------|-----------------|
| 11. PROCESSING LOSSES, DISCARDS, ETC.: | | |
| a. Reporting Facility Financially Responsible. <u>GAIN</u> | | <u>(441.00)</u> |
| b. Other Facilities Financially Responsible: | | |
| Name _____ | _____ | _____ |
| _____ | _____ | _____ |
| _____ | _____ | _____ |
| _____ | _____ | _____ |

| | | |
|--|--|------------------|
| 12. TOTAL LOSSES (Total 11a and 11b) | | <u>(441.00)</u> |
| 13. ENDING INVENTORY | | <u>24,109.00</u> |
| 14. MATERIAL ACCOUNTED FOR (Total Lines 10, 12 & 13) | | <u>24,109.00</u> |

DETAIL OF ENDING INVENTORY REPORTED ON LINE NO. 13

| <u>15. MATERIAL FOR WHICH REPORTING FACILITY IS FINANCIALLY RESPONSIBLE</u> | <u>U-235</u> | <u>URANIUM (Grams)</u> | <u>Wt. % Isotops-235</u> |
|---|--------------|------------------------|--------------------------|
| <u>PEF-1</u> | <u>1485</u> | <u>9,991</u> | <u>14.85</u> |
| <u>PEF-2</u> | <u>181</u> | <u>1,202</u> | <u>15.04</u> |
| <u>PEF-3</u> | <u>2713</u> | <u>13,916</u> | <u>21.01</u> |
| <u>TOTAL - Line 15</u> | <u>4,379</u> | <u>24,109</u> | |

| <u>16. MATERIAL FOR WHICH FACILITIES OTHER THAN THE REPORTING FACILITY IS FINANCIALLY RESPONSIBLE</u> | <u>(Name)</u> | <u>RIS</u> | | |
|---|---------------|------------|--------------|--|
| | | | | |
| | | | | |
| | | | | |
| | | | | |
| | | | | |
| | | | | |
| | | | | |
| <u>TOTAL - Line 16</u> | | | <u>- 0 -</u> | |

| | | | |
|---|--------------|---------------|--|
| <u>17. TOTAL INVENTORY (Same as reported on Line 15.)</u> | <u>4,379</u> | <u>24,109</u> | |
|---|--------------|---------------|--|

| <u>18. MATERIAL IN THE POSSESSION OF OTHERS FOR WHICH REPORTING FACILITY IS FINANCIALLY RESPONSIBLE (Detail Below):</u> | <u>(Name)</u> | <u>RIS</u> | | |
|---|---------------|------------|--|--|
| | | | | |
| | | | | |
| | | | | |
| | | | | |
| | | | | |
| <u>TOTAL - Line 18</u> | | | | |

Prepared by (Signature) _____ Date _____ Approved by (Signature) _____

Handwritten signature and initials

EN:IC

MAR 12 1968

Westinghouse Electric Corp.
Atomic Power Division
P.O. Box 355
Pittsburgh, Pennsylvania 15320

Attention: R. Ischiegg

Subject: SAFEGUARDS CONTROL AND NUCLEAR MATERIAL MANAGEMENT
AT WESTINGHOUSE ATOMIC POWER DIVISION

Gentlemen:

In compliance with the requirement of the Atomic Energy Commission a safeguards control and nuclear material management review will be performed by Messrs. I. Cohen and P. DeLoraine beginning April 1, 1968. The review will cover the period 3/1/67 through 3/31/68 and will include all holdings of nuclear material excluding those under SWM-338 and supply agreement.

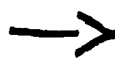

The review will consist of a comprehensive examination of all phases of nuclear material control, including records, measurements, losses and loss mechanisms. You are requested to perform a physical inventory either prior to the arrival of the survey team or during the field review; in either case the survey team will perform independent tests to verify your inventory.

Enclosed are two copies of our "Internal Control Questionnaire." Please complete, returning one copy to the survey team.

Very truly yours,

S. J. Braiden, Chief
Nuclear Materials Management Branch

REC'D. DIV. OF COMPLIANCE
REC'D. N.Y. OFFICE
RECEIVED

MAR 13 10 49 AM '68

Enclosures:
As stated

cc: R. Kirkman, CO I.

DIVISION OF COMPLIANCE
Memo Route Slip

Action _____ Information _____ Concurrence _____ Review _____
 Comment _____ Note & Return _____ Per Our Telecon _____ File _____

3111-537

[Handwritten signature]

| | |
|-----------------------------|---|
| R. W. Kirkman Region I | X |
| J. G. Davis Region II | |
| R. C. Hageman Region III | |
| D. I. Walker Region IV | |
| R. W. Smith Region V | |
| | |

RE: NMM SURVEY OF CHESWICK, PENNSYLVANIA
SITE OF WESTINGHOUSE ATOMIC POWER DIVISION

Attached for your information is a copy of a report of the subject survey. There are also attached copies of two memoranda relating to the report. When additional information is received as requested by NMM, it will be forwarded.

We are currently reviewing the report in connection with a draft instruction on the conduct of surveys at licensee facilities which NMM has forwarded for comment.

- Attachments:
1. Copy of Survey Report NY-231 dtd 1/13/67
 2. Copy of memo fm W. Gilbert, NMM, to S. Braiden, NY, dtd 2/23/67
 3. Copy of memo fm D. George, NMM, to L. D. Low, CO, dtd 2/2/67

C1263

ITEM # 263

[Signature]
Leo Dubinski, CO:HQ

MAR 9 1967

(11)

FROM:

DATE:

SAFEGUARDS REVIEW OF SS MATERIALS HELD AT THE CHESWICK SITE OF WESTINGHOUSE
ATOMIC POWER DIVISION

I. INTRODUCTION

*SHOULD BE 1966 PER PHONE CALL FROM
IRA COHEN ON 1/18/67, WEG.*

This review covers SS material located at the Cheswick site for the period 2/1/65 through 10/31/66. The review covers material held under the following accounts with the Commission:

| | <u>Quantity (g) as of 11/30/66</u> | | |
|------------------------|------------------------------------|--------------|-----------|
| | <u>U</u> | <u>U-235</u> | <u>Pu</u> |
| SNM-338 | 68,990,444 | 2,913,618 | 1608 |
| Supply Agreement TAS - | 22,901 | 3,426 | |

The review did not cover all material held by Westinghouse under New York's responsibility because of the geographic locations of the material balance areas and the nature of the work performed at the areas. Materials not included in this survey, which are held under other leases and under the facility, will be reviewed during March of 1967.

The activities associated with the material reviewed were preparation of enriched uranium oxide pellets and manufacturing of completed fuel assemblies for domestic and foreign reactors. A small portion of the total inventory was being used for research and development efforts.

II. SCOPE OF WORK

The areas covered were:

- a. An Independent test of the inventory;
- b. An evaluation of losses and material unaccounted for;
- c. An evaluation of measurements pertaining to inventory control;
- d. Internal records, reports to the Commission and accounting procedures;
- e. Statistical techniques;
- f. Procedure Manual;
- g. Internal Control.

III. OPINION STATEMENT

It is our opinion that the Material Status Reports prepared as of November 30, 1966 fairly present the transactions for the review period and the physical inventory. The internal control procedures are adequate for safeguards of SS materials. The material unaccounted for and the process losses are reasonable.

IV. RECOMMENDATIONSA. Prior Recommendations

None

B. Current Recommendations

None

V. DISCUSSIONA. Inventory

Prior to the arrival of the survey team, a physical inventory had been completed by WAPD personnel according to their written inventory procedures. The items on inventory, which were listed by job, consisted of assemblies of fuel rods, single fuel rods, containers of pellets, uranium oxide powders and scrap. The survey team initially observed each item. All material was frozen while this was done (this presented no problem because production was a minimum due to plant strike). It was noted that each item that appeared on the inventory sheets agreed with the description of the inventory tag. All of the individual fuel pins were piece counted; there were no discrepancies noted. A portion of the inventory was in sealed shipping containers awaiting shipment overseas. This shipment had been previously observed by the New York Office. Each of the containers were sealed with seals supplied by NY. It was noted that each seal was intact and that each numbered seal was accounted for.

After observation of all items, populations were established for statistical sampling and verification. The populations included 72% of the material on hand. Items excluded were those that could not be verified by sampling or gamma scanning. Separate populations were established for pure compounds and scrap, and single fuel pins. Samples were selected according to plans established in MLT Standard 105D at an AQL of 1.5%.

The items selected in the compound and scrap populations were initially checkweighed; samples were then withdrawn for verification of U-235 by gamma spectrometry. All items checkweighed were in agreement. Measurement of U-235 content indicated excellent agreement for pure compounds and disagreement for scrap items. Additional scrap items were selected for U-235 measurement, these also showed disagreement. The survey team was informed, after discussing the differences with WAPD personnel, that the SS contents assigned to scrap were not measured values. Values assigned to scrap were estimates based on past experience. The survey team noted that the quantities of scrap accounted for .16% of the total inventory on hand and that the estimates would not distort the total inventory values.

Prior to scanning of the fuel pins selected for verification, a section of a pin was prepared from pellets that were analyzed by gamma spectrometry. This pin section was used as a standard. All the selected fuel pins that were measured agreed within counting error with the standard pin. WAPD supplied a list of conversion factors used for inventory purposes, each factor was adequately supported with records supplied by quality control.

The survey team noted that at least 99% of the inventory had been measured by WAPD and that 72% of the inventory (SS quantity) fell into populations which were amenable to verification by the weigh-sample analyze technique. Items not included in the populations were finished fuel assemblies; the survey team reviewed supporting records for values assigned to the assemblies; these were acceptable.

B. Losses and Loss Mechanisms and Material Unaccounted For (MUF)

The major MUF that occurred during the survey period was that associated with the fabrication of fuel for the Connecticut Yankee Power Reactor. The job consisted of fabrication of assemblies of fuel pins (204 pins per assembly), each pin containing approximately 2 kg of uranium in the form of oxide pellets. Three enrichments 3.0, 3.2 and 3.6% uranium 235 were used as fuel. The job was in progress during the field review, however, all pellets and rods had been manufactured; the only production step carried out was the construction of assemblies. The work at WAPD did not include UF₆ conversion to oxide nor scrap recovery, these jobs were sub-contracted. The total receipts for the job were:

| <u>U</u> | <u>U-235</u> |
|--------------|--------------|
| 76,130,739 g | 2,514,618 g |

The job began on 4/1/66; there were no shipments of product, however, there were shipments of scrap to sub-contracted scrap recoverers. To date, recovery values for all scrap shipments have not been reported. There were no previous losses declared for the job.

The book physical inventory difference for the job was:

| | |
|-----------------|----------------|
| <u>U</u> | <u>U-235</u> |
| 330,291 (grams) | 10,426 (grams) |

This BPID represents .43% of the throughput at WAPD. Previous experience at WAPD for similar jobs indicated processing losses (BPIDS) of .33%, .94% and .47%. Data obtained from SAN indicated a process loss of 1.5% for similar work which included UF₆ conversion and scrap recovery; no attempt was made to obtain additional information at other fabrication sites.

In order to estimate the MUF for the job, the production steps were reviewed and the possible operations that would contribute to material losses were determined. During this review it was learned that management could not assign with confidence, values to the various operations wherein losses were known to occur. Also, management was not really concerned about normal operational losses. The practice was to declare a process loss, based upon the difference between their receipts and removals, after a job has been completed and all the scrap has been reprocessed. There are some suggestions in the internal control section for improvement of safeguards control, which were discussed with WAPD management.

The following process losses were estimated by the survey team. WAPD personnel offered assistance in the way of professional judgment and supporting data in the determination of these estimates.

| <u>Type of Process Loss</u> | <u>Kg of Uranium</u> |
|------------------------------------|----------------------|
| 1. Non-recoverable waste to burial | 122 |
| 2. Uranium was water to disposal | 2 |
| 3. Uranium in exhaust system | 27 |
| 4. Uniforms to laundry | * |
| 5. Holdup in equipment | <u>1</u> |

Total estimated process loss

130 152 Kgs.

Estimated MUF (330 - ¹⁵~~130~~ ¹⁷⁸200) kg.

Percent MUF of throughput (²⁰⁰76,131 × 100) = .26
₁₇₈ .23

The following estimates of the measurement errors have been established by the survey team. These estimates were calculated by the survey team using measurement data supplied by WAPD personnel.

| <u>Measurement</u> | <u>Estimated Error Kg of Uranium</u> |
|---|--|
| 1. Virgin uranium oxide powder | 1 |
| 2. Uranium in fuel pins | 2 |
| 3. Uranium contained in scrap sludges | 50 |
| 4. Uranium contained in uniforms to laundry | * |

The survey team noted that some jobs which were in process during the survey period showed small gains and losses (differences of less than 1 kg); these were not reviewed.

It is the opinion of the survey team that the process losses and MUFs for the period were reasonable.

C. Measurement Procedures

The analytical measurements are not performed at the Cheswick site, samples of virgin uranium oxide received and product pellets are shipped to the Waltz Mill site for assay. A measurement review at The Waltz Mill site will be performed in March of 1967. However, the survey team agreed with U-235 values that were assigned to pure uranium oxide pellets and powders which were sampled during inventory verification. The survey team noted that all scales used for inventory purposes were routinely calibrated.

D. Records and Reports

Westinghouse maintains a double entry record system for safeguards control of SS materials held under their lease agreement. An examination of this system indicated that all records are adequately maintained to show the inventory on a monthly basis. Accounting procedures are consistent with AEC standards for safeguards control of SS materials.

The Interim Material Status Report (November 30, 1966) and June 30, 1966 report fairly presented the transactions for their respective periods.

E. Statistical Techniques

There was some use of statistics in that data of some measurements had been maintained. A comment concerning the use of this data appears in the Internal Control section.

F. Procedure Manual

The procedure manual covering the entire WAPD facility had been previously approved. The survey team noted that there were no significant changes at the Cheswick site that would require an amendment to the manual.

G. Internal Control

The overall internal control of SS material was acceptable, however, the survey team noted some practices which they felt should be investigated by WAPD management. Management was advised of the following findings:

1. When the pelletizing operation is performed considerable quantities of non-recoverable wastes are generated and forwarded to land burial. In the past, the number of containers discarded have not been recorded nor was there any attempt to estimate the quantity of material discarded. The survey team suggested that WAPD management give consideration to placing estimates upon all material discarded and record these estimates as process losses.
2. It was noted that during the review period considerable quantities of grinding sludge had been sub-contracted for uranium recovery. The uranium quantities assigned to the shipment were based upon previous (47) measurements of grinding sludges. Each container shipped was not analyzed. The survey team observed the data from which an average value was obtained. The uranium values ranged from 58 - 87% and the data did not appear to represent a normal distribution. The survey team suggested that WAPD have their statistician review the data and also consider the possibility of measuring the contents of each container.

3. In the process of evaluating the MUF, an attempt was made, by the survey team, to estimate holdup in equipment. It was noted that in the vicinity of each discrete operation in the pellet fabrication area were exhausts leading to overhead ductwork which ended at the main filtering chamber. Portions of the overhead ductwork were surveyed for U-235 using the crystal from the portable gamma spectrometer. Considerable gamma activity was noted at portions of the ductwork, the survey team estimated that some portions (3 foot lengths) could contain as much as 1 kg. of low enriched uranium. The material heldup in the ductwork was not included in the physical inventory.

Ira Cohen
Ira Cohen, Team Leader

2/28/67
Date

Warnell Brown
Warnell Brown, Auditor

2/28/67
Date

P. J. DeLorenzo
P. J. DeLorenzo, Auditor

2/28/67
Date

S. J. Braiden, SS Representative
New York Operations Office

Feb 23 1967

William E. Gilbert, Chief, Survey and Appraisal Branch
Division of Nuclear Materials Management, Headquarters

SURVEY REPORT NY #231 - WESTINGHOUSE ATOMIC POWER DIVISION (GIESWICK
PLANT)

The subject report has been reviewed and the narrative content of Section V. B., "Losses and Loss Mechanisms and Material Unaccounted For (MUF)" has been discussed with Ira Cohen of your office.

While the intent of the Loss Mechanism Review was focused in the proper direction, the narrative discussion in Section V. G., "Internal Control," tends to confuse the reader by implying the licensee had no idea of the quantities of SS material discarded, buried, held up in equipment, etc.

Also, in the table on Page 4, it is improper to combine measurement uncertainties and process losses for purposes of evaluating the MUF since MUF should not include process losses and measurement uncertainties may be either a positive or negative number. What NY may intend is that items 1, 2, and 7 are estimated errors or estimated differences due to measurement uncertainty as opposed to uncertainty of measurement.

Discussions with Mr. Cohen answered the questions we posed, and he stated that workpapers describe the approach used by the survey team to arrive at "quantitative values" for plant losses. However, the Division of Compliance will not necessarily have the benefit of any such detailed discussion. Rather, they will receive the survey report which, through choice of words, possibly may be misleading.

Therefore, I suggest you rewrite the appropriate sections of the survey report, clearly distinguishing between MUF, NOLs, and measurement uncertainties and not combine measurement uncertainties and process losses. Also, clarify what portions of the MUF are based upon measurements and estimates of the survey team as opposed to the statements of the licensee.

cc: C. L. Henderson, REG

10552

2-24-67
11-27

UNITED STATES GOVERNMENT

Memorandum

TO : Lawrence D. Low, Director
Division of Compliance

FROM : Douglas E. George, Director
Division of Nuclear Materials Management

SUBJECT: SAFEGUARDES SURVEY REPORT

NM:JVC

DATE: MAR 2 1967

In accordance with the August 1, 1966, agreement between the General Manager and the Director of Regulation (Procedure for Implementing and Administering the Commission's Domestic Safeguards Program for Licensed Special Nuclear Material) two copies of Survey Report NY #231 - Westinghouse Atomic Power Division (Cheswick Plant) are enclosed.

Although no recommendations were made in the report, Westinghouse management was advised of internal control practices which should be investigated. Three suggestions were made in Section G, "Internal Control."

New York was advised by the Headquarters Division of Nuclear Materials Management (memorandum dated February 25, 1967, subject: Survey Report #231, cc: C. L. Henderson, REG) to rewrite certain sections of the survey report, clearly distinguishing between MUF, NOLs, and measurement uncertainties and not combine measurement uncertainties and process losses to avoid possible confusion to the reader. New York also was advised to clarify what portion of MUF are based on measurements and estimates of the survey team as opposed to statements of the licensee.

I will provide you with two copies of the revised report (or rewritten sections) when these have been received from NY.

Enclosure:

As stated above (two copies)

cc: John V. Vinciguerra, AGIA (w/o enclosure)
C. L. Henderson, REG (w/o enclosure)

7 0823



Buy U.S. Savings Bonds Regularly on the Payroll Savings Plan

UNITED STATES GOVERNMENT

Memorandum

TO : Lawrence D. Low, Director
Division of Compliance

FROM : Douglas E. George, Director
Division of Nuclear Materials Management

SUBJECT: SAFEGUARDS SURVEY REPORT - WESTINGHOUSE (CHESWICK PLANT), NY #231

NMM:JVC

DATE: MAR 14 1967

I

In accordance with my March 2, 1967, memorandum to you, subject as above, enclosed are two copies of rewritten sections of the report.

Enclosure:

As stated above (two copies)

cc: John V. Vinciguerra, AGMA (w/o enclosure)
C. L. Henderson, REG (w/o enclosure)

*Revised
pc
pages inserted.
3/20/67*



From CU - 1777

0727

Buy U.S. Savings Bonds Regularly on the Payroll Savings Plan

DOCKET INPUT FORM

(DOC NO)

40 003558

(FOLDERS) 1

(BOX) 41/95

(ANALYSTS) [initials]

(ORGANIZ) Westinghouse Electric Corp.

(ADRES A) PO 125 (CITY A) Blairsville (ZIP A) (STATE A) PA
(ADRES B) (CITY B) Cheswick (ZIP B) (STATE B) PA
(ADRES C) ITEM # 265 (CITY C) (ZIP C) (STATE C)
(ADRES D) (CITY D) (ZIP D) (STATE D)
(SITES) (LAIDS) (BLDGS)

Table with columns: (LIC NO A), (EFFDATA), (EXPIRA), (CROSRFA), (ISOTOP 1-6), (OPERTN 1-6), (COMENT A). Includes handwritten values like '00509', '123164', and '00'.

Table with columns: (LIC NO B), (EFFDATB), (EXPIRB), (CROSRFB), (ISOTOP 7-11), (OPERTN 7-11), (COMENT B). Includes handwritten values like '004971', '123161', and 'C 003640'.

Table with columns: (LIC NO C), (EFFDATC), (EXPIRC), (CROSRFC), (ISOTOP 12-14), (OPERTN 12-14), (COMENT C). Includes handwritten values like '004415' and '00'.

Table with columns: (LIC NO D), (EFFDATD), (EXPIRD), (CROSRFD), (ISOTOP 15-16), (OPERTN 15-16), (COMENT D). Includes handwritten values like '000384' and '00'.

Table with columns: (LIC NO E), (EFFDATE), (EXPIRE), (CROSRFE), (LIC NO F), (EFFDATF), (EXPIRF), (CROSRFF). Includes handwritten values like '000037', '000145', '070161', and '00'.

(SITE DOC) 01 02 03 04 05 06 07 08 09 10 11 12 13 14 15 16 17 18 19 20 21 22 23 24 25
26 27 28 29 30 31 32 33 34 35 36 37 38 39 40 41 42 43 44 45 46 47 48 49 50

(CLEARED) Y N U Licensee Consultant AEC NRC ORNL Other

(CATEGORY) 1(≥66) 1a(OK) 1b(No) 1c(Und); 2(≤65) 2a(OK) 2b(No) 2c(Und)

(COMENT 2) Check on Cheswick, Pa inventory (receipts from Blairsville). See Item 13.

(ACTION) None Referral(ORNL) Followup(NRC) Visit Other

ANALYSIS FORM

DOC NO

40 00 3558

Category

By

Date

FEB 07 1978

ACCES NO

Category

By

Date

Category

By

Date

DOCUMENTS FOUND IN FOLDER: (Check nos. on reverse side under (SITE DOC) which apply.)

No. Document(s)

- 01 Appl. for Lic. _____
- 02 Copy of Lic. _____
- 03 _____ Lic. Amendment(s) _____
- 04 _____ Reporting ID Symbol(s): _____
- 05 _____ Correspondence: _____
- 06 Material Transfer Forms: AEC SF 101-WFP-LYT-48 : 27 drums to Oak Ridge
- 07 _____ Material Lease Form(s): _____
- 08 _____ Nuclear Material Draft: _____
- 09 _____ Materials Data Input: _____
- 10 _____ Waste Disposal: _____
- 11 _____ On-Site Waste Burial: _____
- 12 _____ Off-Site Waste Burial: _____
- 13 _____ Form 741 or 742: _____
- 14 _____ Quantities on Site: <1 gm <1 kg <10 kg <100 kg <1000 kg >1000 kg of: _____
- 15 _____ License Nos. NOT terminated: _____ AS OF: _____
- 16 Compliance Inspect Rept: OK
- 17 _____ Inspect Findings: _____
- 18 Status Certificate: SUC-509 have been or will be transferred to Westinghouse Atomic Fuel Plant, Cheswick
- 19 _____ Contract No: _____
- 20 _____ Environmental Impact: _____
- 21 _____ Radiation Safety Check Form: _____
- 22 _____ Site Shut Down: _____
- 23 Material Status Rept: 46,311 gms U-235 on 6/30/61; 0 gms U-235 as Exhibit C
- 24 _____
- 25 _____

NOTES: _____

No. Check List

- 26 One or more licenses expired AFTER 1965 (Category 1): _____
- 27 ALL licenses terminated BEFORE 1966 (Category 2): _____
- 28 Company Name changed: _____
- 29 _____ Company went out of business: _____
- 30 _____ Site not under responsible control: _____
- 31 _____ License covered more than one facility (site): _____
- 32 _____ Intra-Company Transfers: _____
- 33 _____ Radioactive material properly disposed of: _____
- 34 _____ Radioactive material improperly disposed of: _____
- 35 _____ Loaned or leased material returned: _____
- 36 _____ On-Site disposal: _____
- 37 _____ Off-site disposal to licensed group: _____
- 38 _____ Material never received under license: _____
- 39 _____ Incomplete accounting of materials: _____
- 40 _____ Site probably contaminated: _____
- 41 _____ Radiation survey rept(s): _____
- 42 _____ Radiation levels: _____
- 43 _____ 10CFR citations: _____
- 44 _____ Transferred to State Licensing as of: _____
- 45 _____
- 46 _____
- 47 _____
- C1264
- ITEM # 266

NOTES: _____

(7)

ITEM # _____

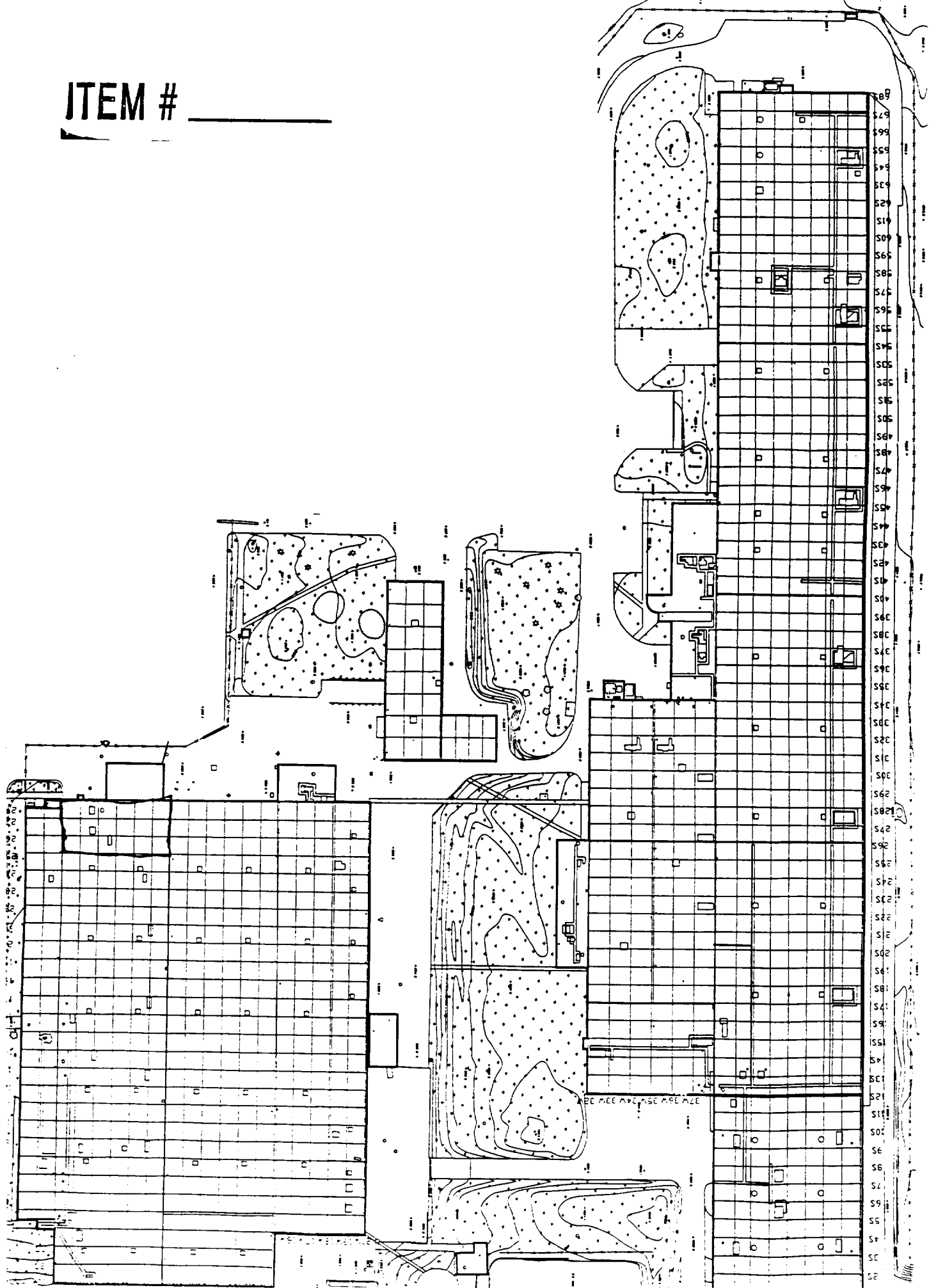

11/16/94 - Westinghouse Blairsville 256-3111/Safety Office
Wayne George 256-3162/Safety Manager

12/23/94 - Can Begin Work *Friday*

1/1/95 - Work To Be Completed

1/2/95 - Westinghouse Back To Work

One Weekend + One Week

- Possible Later on Weekends

Gage Lab - Primary

- Floor is Clean Except For Sump, One Pipe, Possible Second Pipe
- Remove Carpet, Scan Floor By Westinghouse

Floor to be Scarfed ($\frac{1}{4}$ " deep)

28-S to 25-S

9-W

to

6-W

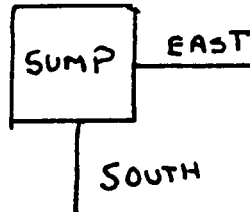

C³ to Restore

"Facilities" Personnel Likes a Particular Skim Coat

No Need to Paint at This Time - Westinghouse Will Paint Floor

At Sump Room

- Construct A Dust Barrier @ 26-S Vicinity

Scarf With³ HEPA Vacuum

Pentek - C³ to Get Equipment - Dust Recovery System

Can Put Barrier @ Door on 26-S - 25-S @ 6-W

8" W. Trench w/Steel Plate Cover - Remove to Survey

Proposed Meeting Room Never Constructed

Be ready to Core at Anchor Bolt Locations

Need Small Scarfing Equipment For "Tight" Areas
(Hand Held - Pentek)

Plan on Scarfing All the way to the walls

- 1 - New Rolling Door
- 2 - Double Doors & Man Door

C³ = Tyveks
55 Gallon Drums HEPA - No Special Filter For Respirator
Lumber Shoe Covers
Plastic Sheeting Gloves

Cover Doorways & Small Open Areas

C³ = Wet/Dry Vacs

Westinghouse = HPs

Top Priority - Gage Lab - False Wall (26 X 12)
- Cover All Walls W/Plastic
- 42ft - Room Length
- Production Room 25/S+
9/W to 5/W

2nd Priority - Finishing Supervisors Room - Definite Scarf

3rd Priority - Scarfing Floor Areas - "Outside"

Gage Lab - Encapsulate Leveling Stand - Preferably
DO NOT MOVE STAND
- Metal, Concrete-Field Sump
- Maybe 2 Pipes Heading "East" 20ft and ?ft
- " 1 Pipe " "North" 6ft

Existing concrete Floors = 8" Thick

Sump 5ft. Long X 2½ ft Wide X 1 ft Deep

C³ Equipment Needs: Fork Truck With Barrel Grabs
- Saw Cutting
- Coring
- Jackhammer - Westinghouse Has Air, Water
Electricity, Lighting,
- Scarfing
- Burning And Welding - Metal Plate Trenches
- Skim Coat - Hard Rubber Fork Trucks
25 ton Loads

40 Hr. OSHA

HP Training By Westinghouse - Training prior To Actual Work
Starting

PRE-MOBILIZATION/MOBILIZATION

- Confirm 40-Hr. OSHA Training is current for all Personnel
- Procure 55-gallon drums and transport to Blairsville
- Undergo Health Physics Training
- Move and set up job trailer inside fenced in parking area
- Meet with Pentek, and decide on equipment needs
- "Deliver" Pentek equipment to job site
- Procure Concrete Topping product
- Procure Plastic Sheeting Material
- Procure Dimension Lumber
- Confirm good edge on concrete saw blade
- Deliver HEPA vacuums to work site
- Deliver wet/dry vacuums to work site
- Deliver Fork Truck to work site (include barrel grabs)
- Deliver core drill to work site (to core and remove anchor bolts) (probably 4" D. core drill)

GAGE ROOM - TOP PRIORITY AREA NO. 1

- Remove tables and desks from office area, chairs also
- Remove carpeting from office area
- Provide assistance, as requested, to H.P. doing floor scan
- If necessary, plastic cover the walls, ceiling, and any openings
- If necessary, scabble $\frac{1}{4}$ " off the floor surface
- " " , place concrete floor topping

- In the lab, encapsulate the granite leveling table with plastic
- Disconnect and relocate any tools, Machines, furniture to the South area of the lab
- Construct a temporary wall (lumber and plastic) along the interior column line
- Cover the open wall area between the Lab and the Office with plastic
- Cover all "stored" furniture and Machines with plastic
- Saw cut the floor at the perimeter of the sump
- Jackhammer the concrete surrounding the sump
- Remove the concrete filled metal sump and crate for off-site shipment
- "Chase" the pipe between the sump and the East wall
- " " " " " " " " North "
- If necessary continue "chasing" this pipe into the Production Area
- Backfill the sump and pipe excavations
- Install a top coating over the sump and pipe locations

- If determined by Westinghouse that any floor areas in the lab are "hot", scarf those areas and place floor topping
- Relocate all drums of debris to outside staging area
- Perform general clean-up
- Remove plastic protections and relocate all machines, furniture, etc.

PRODUCTION AREA - TOP PRIORITY AREA NO. 2

- Work area approximately 66 ft X 10 ft = 660 s.f.
- Work area between column line 9W and 5/6W, and between column line 25S and 25/26S
- Scarf the floor area
- Containerize the concrete cuttings
- Core any encountered anchor bolts (probably 4" D. core drill)
- Relocate drummed waste to outside staging area
- Place concrete floor topping
- Construct plastic enclosures at doorway and as needed

SUPERVISOR - FINISHING OFFICE - NO. 2 PRIORITY AREA

- Remove all furniture
- Remove Carpeting
- Install plastic sheeting over any openings
- Scarf the concrete floor
- Drum the rubble and place in outside staging area
- Place concrete topping
- Reinstall the carpeting
- Replace the furniture
- Remove the plastic sheeting
- Floor area 18 ft X 18 ft = 324 s.f.

GENERAL FLOOR AREA - NO. 3 PRIORITY AREA

- Floor Area - (50 ft X 50 ft) - (18 ft X 18 ft) = 2176 s.f.
- Scarf floor surface
- Containerize rubble and store in outside staging area
- Core anchor bolt locations (probably 4" D. core drill)
- Place concrete floor topping

DEMOBILIZATION

Load and relocate all drums of debris to Forest Hills facility

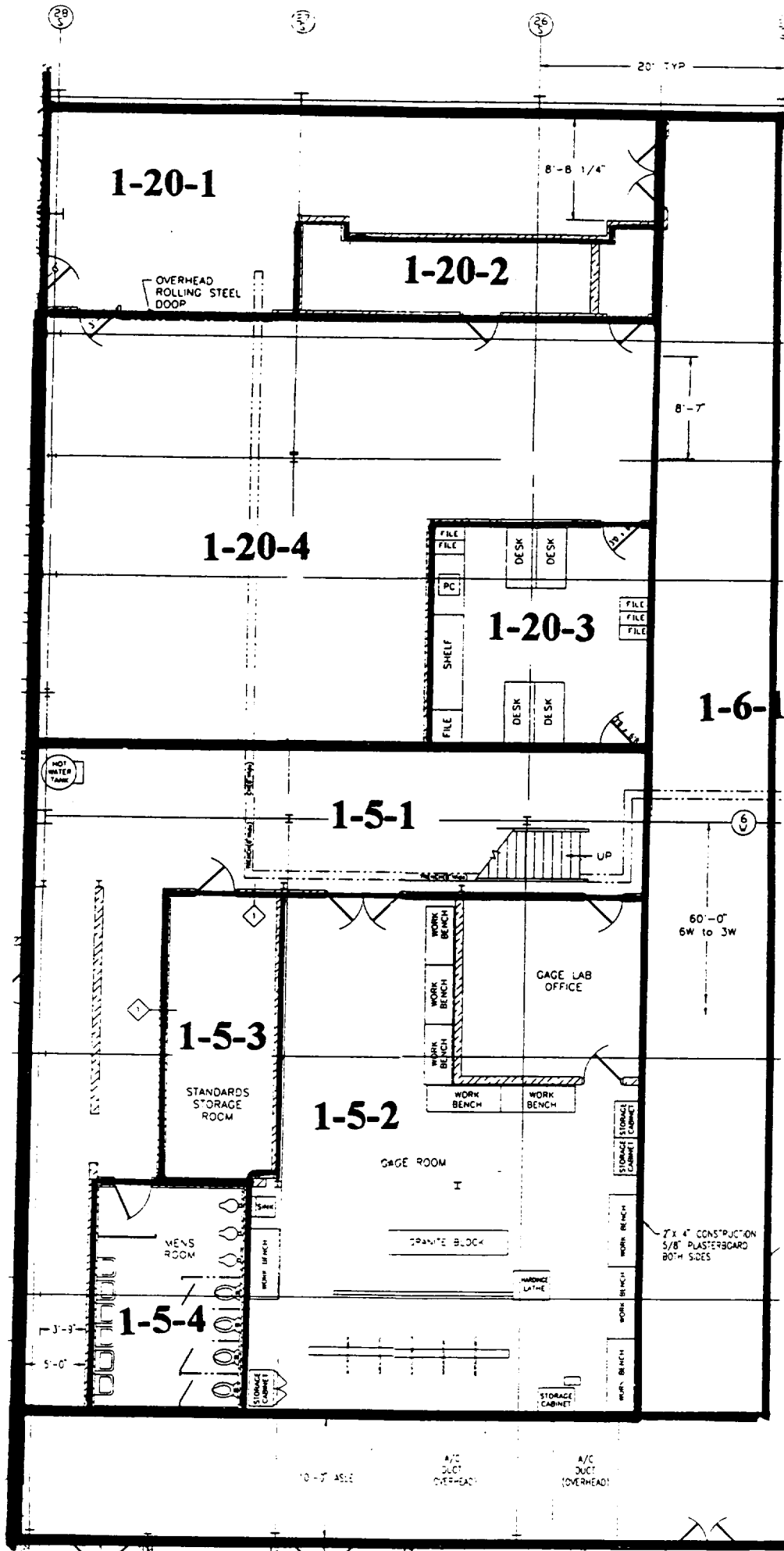

NORTH →

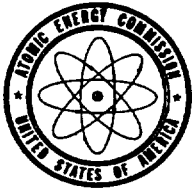

UNITED STATES
ATOMIC ENERGY COMMISSION
WASHINGTON, D.C. 20545

IN REPLY REFER TO:

40-3558

Westinghouse Electric Corporation
Materials Manufacturing Department
P. O. Box 128
Blairsville, Pennsylvania

NOV 19 1964

Attention: Mr. R. D. Rowley

SUBJECT: NOTICE OF LICENSE EXPIRATION

Gentlemen:

Notice is given that Source Material License Number 80C-509 expires on **December 31, 1964.**

If you desire to continue your program using source material(s), an application for renewal of the license should be filed with this office. It is to your advantage to file such an application at least thirty (30) days before the expiration date of your existing license. The application should be submitted using Form AEC-2, enclosed, in accordance with the instructions provided with the form. Your program will then be covered by your existing license until action is taken on your application for license renewal. (Title 10, Code of Federal Regulations, Part 40, Section 40.43(b)). If an application is received less than 30 days prior to the expiration date of your license and cannot be processed before your existing license expires, this could result in your possessing source material without a valid license.

If you do not wish to renew your license, please complete the enclosed form "Certification of Status of Source Material Activities under United States Atomic Energy Commission Source Material License Number 80C-509", and return it to this office.

If you have obtained an amendment which has extended the expiration date of the above license or if a new license has been issued which supersedes the above license, please disregard this notice.

This notice of your license expiration is sent for your convenience and it should not be interpreted that similar notices will be sent in the future. The responsibility for timely submission of an application for license renewal remains with the licensee.

cc: Document Room
Compliance
Supplementary

Very truly yours,

Dictator D. A. Nussbaumer 11/19/64

Approved RRR

Enclosures:
10 CFR, 20 & 40
Form AEC-2
"Certification. . ."

Donald A. Nussbaumer, Chief
Source & Special Nuclear Materials Branch
Division of Materials Licensing

ITEM # 277 C1265

EXHIBIT

Schedule of Meters TSI 800-31

| Item # | Date | M/F/T/W | Amount | Invoice |
|------------|---------|------------|--------|---------|
| 800-336-05 | 1-21-61 | M, F, T, W | 21 | 570 |
| 800-336-07 | 1-27-61 | M, F, T, W | 512 | 570 |
| 800-336-08 | 5-22-61 | M, F, T, W | 809 | 570 |
| 800-336-09 | 5-23-61 | M, F, T, W | 926 | 570 |

| | | | | |
|----------------|---------|------------|---|---|
| 800-38-02 | 2-15-61 | M, F, T, W | 6 | ? |
| 88 Station WOS | 6-2-61 | NOTIFY | 2 | ? |

Schedule of Meters TSI 800-31

| | | | | |
|------------|---------|------------|------|------|
| 800-115-02 | 1-29-61 | M, F, T, W | 6800 | 576 |
| 800-115-03 | 1-29-61 | " | 6658 | 606 |
| 800-115-04 | 1-30-61 | " | 296 | 259 |
| 800-115-05 | 1-20-61 | " | 2020 | 1837 |
| 800-115-06 | 1-20-61 | " | 1125 | 1160 |
| 800-115-07 | 1-22-61 | " | 1116 | 1160 |
| 800-115-08 | 1-20-61 | " | 336 | 1160 |
| 800-115-09 | 1-20-61 | " | 336 | 1160 |
| 800-115-10 | 1-20-61 | " | 336 | 1160 |

| | | | | |
|--------------|---------|--|-------|-------|
| 800-336-36 | 1-9-61 | | 2672 | 849 |
| 800-336-37 | 1-19-61 | | 1357 | 1264 |
| 800-336-38 | 1-23-61 | | 66 | 60 |
| 800-338-39 | 1-20-61 | | 4195 | 302 |
| 800-338-40 | 1-20-61 | | 539 | 704 |
| 800-338-41 | 8-6-61 | | 902 | 610 |
| 800-338-42oc | 5-25-61 | | 901 | 639 |
| 800-338-43 | 6-5-61 | | 25 | 22 |
| 800-338-44 | 5-26-61 | | 18687 | 17390 |
| 800-338-45 | 6-30-61 | | ? | ? |
| 800-338-47 | 6-20-61 | | 1007 | 1059 |
| | | | 5053 | 5155 |
| | | | 981 | 201 |
| | | | 37452 | 37556 |

ITEM #

1183



**COPYRIGHTED DOCUMENT ADDRESSED UNDER
FOIA/PA**



For hard copy, refer to PDR Folder:

FOIA/PA: 2000-0041

Requester Name: J.P. Pohl/Gambino

Response Date: 7-12-2000

Record(s): C:267 (1pg)

Westinghouse Electric Corporation

*in manual
2/2/71 Heit*

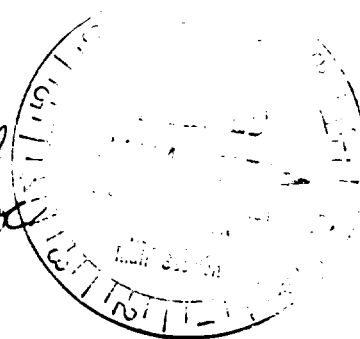

*T
C
C*

Westinghouse Building
Gateway Center
Pittsburgh Pennsylvania 15222

December 30, 1970

HP

U. S. Atomic Energy Commission
Division of Materials Licensing
Washington, D. C. 20545

For Div. of Compliance

Attention: Mr. Donald A. Nussbaumer, Chief
Fuel Fabrication and Transportation Branch

Subject: Application for a Broad Materials License for
the Nuclear Fuel Division at the Cheswick Site,
License SNM-338, Docket 70-337

Gentlemen:

The Westinghouse Electric Corporation hereby requests the re-
vision of License SNM-338, Docket 70-337 in accordance with our
application dated December 16, 1969, as revised by our transmit-
tal dated June 17, 1970, and the attached application. These
three applications revise the license in its entirety and will
supersede all previous transmittals on this docket which are not
included by reference in the applications. Specifically, the
previous transmittals still active are those dealing with author-
izations for shipping packages (our application dated November 18,
1966 and all subsequent revisions thereto) and those dealing with
nuclear materials safeguards (our transmittal dated July 3, 1968,
as revised).

Please send the revised license to me at the above address.

If you have any questions, please write to me at the above address
or telephone me collect, (412) 255-3907.

Very truly yours,

Karl R. Schendel

Karl R. Schendel
License Administrator

KRS: sw

Attachment: 7 copies transmitted

*268
C/358*

ITEM # 358

4221

Westinghouse Electric Corporation

*in manual
2/27/71
JWC*

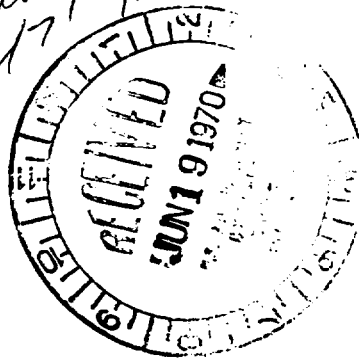

~~Handwritten scribbles~~

Gateway Center
Box 2278
Pittsburgh Pennsylvania 15201

*CROCKER
W/B
HP*

June 17, 1970

U. S. Atomic Energy Commission
Division of Materials Licensing
Washington, D. C. 20545

Attention: Mr. Donald A. Nussbaumer, Chief
Fuel Fabrication and Transportation Branch

Subject: Application for a Broad Materials License for
the Nuclear Fuel Division at the Cheswick Site,
License SNM-338, Docket 70-337

For Div. of Compliance

Gentlemen:

The Westinghouse Electric Corporation hereby requests the re-
vision of License SNM-338, Docket 70-337 in accordance with our
application dated December 16, 1969, as revised by the attached
application. These two applications revise the license in its
entirety and will supersede all previous transmittals on this
docket which are not included by reference in the applications.
Specifically, the previous transmittals still active are those
dealing with authorizations for shipping packages (our applica-
tion dated November 18, 1966 and all subsequent revisions
thereto) and those dealing with nuclear materials safeguards
(our transmittal dated July 3, 1968, as revised).

The revisions included in the attached application have been pre-
pared in response to the enclosure accompanying your letter of
March 4, 1970. The following discussions, numbered to correspond
with questions appearing on that enclosure, did not seem par-
ticularly appropriate for inclusion in the license application.

Question 4. On-site transfers of SNM are subject to
the general surveillance of the site health physics
personnel. The transfer containers may be packagings
which have received approval from the AEC for delivery

*C/269
③*

ITEM # 360

I

1910

June 17, 1970

to a carrier. If not, the container design is based on nuclear criticality safety provisions as they appear in the license, plus structural requirements dictated by the nature of the material and the necessity to prevent damage, release, change in the degree of moderation or similar considerations. On-site moves, almost by definition, are accomplished by a Westinghouse employe who is experienced in or has been instructed in the precautions required of him. In particular, transfers of plutonium-bearing components are carefully controlled to assure the protection of the material and strict compliance with license requirements.

Question 5. The demonstrative portion of the license referred to (Paragraph 1.9.2) deals with the "components" at any enrichment for which authorization for up to 1000 kg ^{235}U is requested in Paragraph 2.1.3. The 20 kilogram quantity in any chemical or physical form is basically intended to apply to laboratory activities involving analysis and possible sample storage if required. It might be pointed out that the Analytical Laboratory provides significant services to the Astronuclear Core Operation which is located at Cheswick.

Question 7. Westinghouse has no current application at NFD Manufacturing at Cheswick for the concentration control limit. It has been included as a logical feature of a broad license. If an application which is within the authorized scope of the license arises, the MPV will be applied strictly as described. If an application occurs which is not within the scope of the license, a suitable amendment will be obtained before commencing operations.

Question 10.a. The values in the table were derived using LEOPARD calculations as stated on Page 63 of the application. The questioned values have been re-evaluated.

Question 12. Westinghouse has made no changes in the requirements for emergency procedures in the light of recent developments related to the license conditions desired by the Commission. Please note that

June 17, 1970

Section 1.11 of the application demonstrates that there would be no off-site effects as the result of the maximum credible accident.

Please send the revised license to me at the above address.

If you have any questions, please write to me at the above address or telephone me.collect, (412) 255-3907.

Very truly yours,



Karl R. Schendel
License Administrator

KRS:sw

Attachment: License Application
7 copies transmitted

DOCKET NO. 70-337-1086
-1143 • -1151
(Handwritten initials)



Westinghouse Electric Corporation

Power Systems

Box 355
Pittsburgh Pennsylvania 15230

(Handwritten notes and signatures)
10-13-71
W. B. ...

October 13, 1971

For Div. of Compliance *(Handwritten initials)*

U. S. Atomic Energy Commission
Division of Materials Licensing
Washington, D. C. 20545

Attention: Mr. Richard E. Cunningham, Acting Director

Gentlemen:

Subject: Waste Management Programs

In accordance with your letter, dated July 13, 1971, Westinghouse hereby transmits seven copies of each of the waste management programs applicable to the special nuclear material licenses listed in your letter.

We hope that the enclosed data will contribute to a realistic interpretation of Paragraph 10CFR20.1(c). If we can be of any further service, or if you have any questions, please write to me at the above address, or telephone (412) 373-4652.

Very truly yours,

(Handwritten signature: Karl R. Schendel)

Karl R. Schendel
License Administrator

KRS:jh

Attachment: 7 copies transmitted

(Handwritten notes)
270
C/...

ITEM # 389

(Handwritten circled number)
75

WASTE MANAGEMENT PROGRAM
Nuclear Fuel Division, Cheswick
SNM 338
Building 7

I. Waste Identification and Characterization

- A. Building 7 is a low bay concrete block building used for development work. Low level solid wastes are stored outside. The retention tanks for liquid waste treatment are located underground adjacent to the building. The area is enclosed by an 8 foot security fence.
- B. 1. There are no manufacturing processes that by themselves generate radioactive waste. Radioactive waste is generated primarily from the cleaning of tools and equipment, from the discard of worn tools, obsolete equipment, and non re-useable containers, and from various devices required by the health and safety program.

2. Waste Categorization

a. Solid

- 1) Plastic gloves and paper towels required by the health and safety program.
- 2) Used absolute filters.
- 3) Fiberboard containers used to store and ship UO₂ powder.
- 4) Obsolete processing equipment.
- 5) Protective clothing worn by personnel.
- 6) Miscellaneous floor sweepings, rags, wood, and metal which are contaminated by radioactive materials.

b. Liquid

- 1) Equipment and floor wash water.
- 2) Coolant water from grinding operations.

c. Gas

- 1) Exhaust air.

I. Waste Identification and Characterization

B. 3. Identity

- a. The contamination in the solid waste is in the form of natural, depleted or low enriched, less than 5% isotope U₂₃₅, uranium dioxide powder. The average amount of UO₂ contained per DOT approved drum or carton is 45 grams. It is estimated the average amount of UO₂ per laundry bag is less than one gram.

There is no permanent storage of solid waste on site. Waste is only held long enough to accumulate sufficient quantities for truck shipment to a commercial waste disposal company.

- b. The liquid waste consists of varying concentrations of depleted, natural and low enriched, less than 5% isotope U₂₃₅, uranium dioxide powder suspended in water. Liquid waste is held in quarantine tanks until measured and released.
- c. The exhaust air contains low concentrations of depleted, natural and low enriched, less than 5% isotope U₂₃₅, uranium dioxide powder.

4. Quantity

- a. Solid waste is included in the quantities shown for Building 5B.
- b. In 1970, 75 grams of uranium were accounted for in liquid waste.
- c. In 1970, less than $.5 \pm .5$ grams of UO₂ were discharged in exhaust air.

5. Inventory

- a. The inventory of solid waste is included in the quantities for Building 5B.
- b. The tanks in the liquid waste treatment pit have a capacity of 6000 gallons.

II. Treatment and Handling

- A. The liquid waste in the retention tanks is agitated to obtain a homogeneous mixture. One quart samples are collected from two locations on the tank.

Based upon the radiometric analysis, the liquid is pumped to another retention tank. In this tank the liquid is diluted to comply with state and federal limits.

The diluted waste is discharged through 200, 60 and 5 micron filter stages to the municipal sewer.

- B. See Attachment 2.
C. None

III. Disposition

A. Categories

1. Liquid waste is monitored, filtered and discharged to the municipal sewer, which feeds into a municipal treatment plant.
2. Solid contaminated waste is transferred to the Nuclear Engineering Company, a commercial nuclear waste disposal firm.

B. Concentrations

1. The average liquid concentrations prior to filtration in 1970 was $7.8 \times 10^{-7} \mu \text{ Ci/cc}$. The maximum concentration was $9 \times 10^{-7} \mu \text{ Ci/cc}$.
2. The average daily air concentration in 1970 was $0 \mu \text{ Ci/cc}$. The maximum concentration was $1 \times 10^{-13} \mu \text{ Ci/cc}$.

III. Disposition

C. Surrounding Area

The plant site is located approximately 18 miles northeast of Pittsburgh, Pennsylvania, in semirural Harmar Township, near the town of Cheswick. The site contains 125 acres on a nearly level plateau about 200 ft. above the nearby Allegheny River. The community surrounding the site consists of single family homes and small industrial plants. The approximate population of the area is 3000. The mean seasonal meteorological conditions* are as follows.

| | Spring | Summer | Winter |
|---------------------|--------|--------|--------|
| Temperature (°F) | 50 | 67 | 31 |
| Mean Wind Direction | W/SW | W/SW | W/SW |
| Humidity (percent) | 50 | 52 | 65 |
| Rainfall (inches) | 3.08 | 3.88 | 2.75 |

* Source - National Weather Service

IV. Future Plans

This facility is at a very low activity level. No plans for systems changes are contemplated at this time.

October 1, 1971

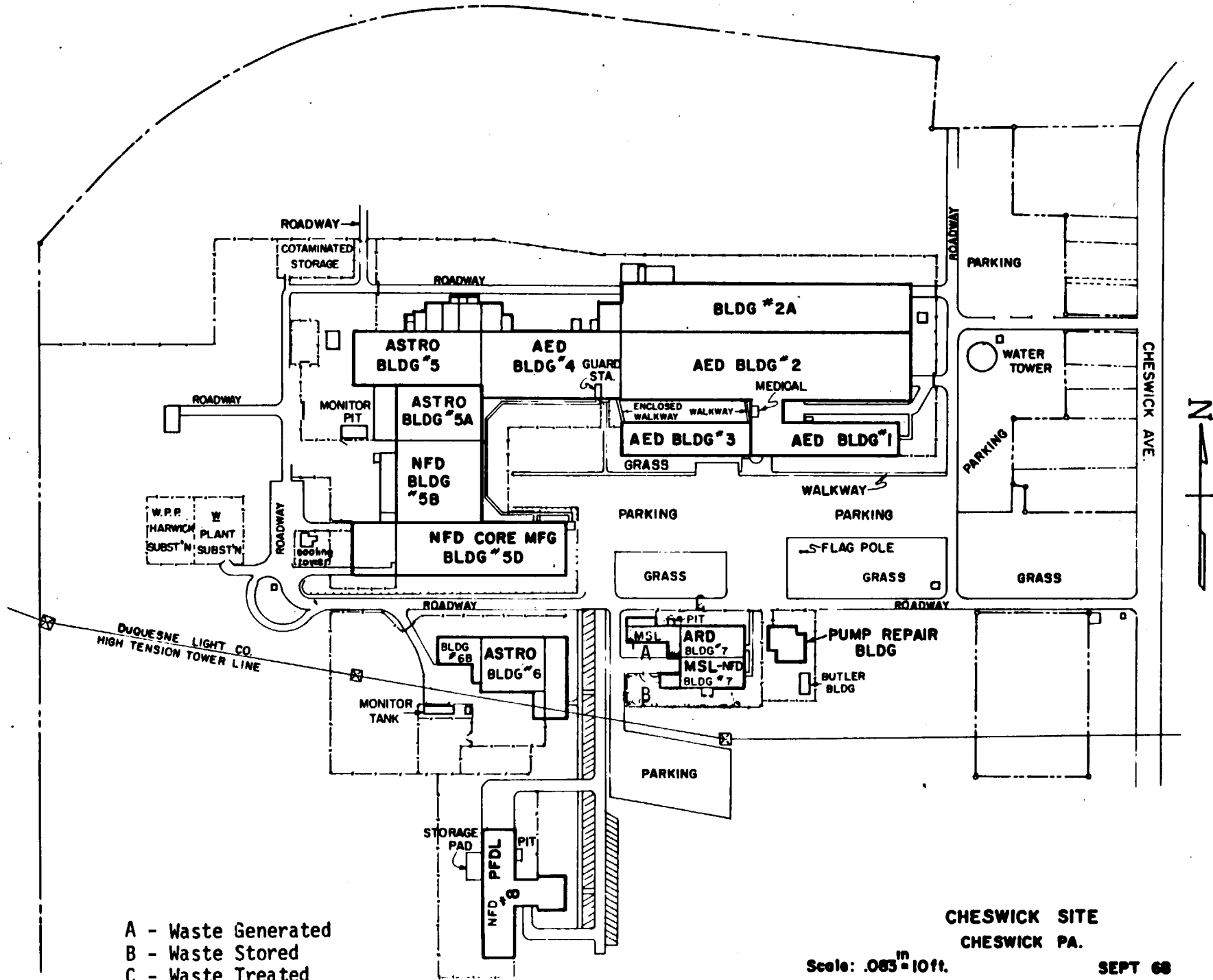

- A - Waste Generated
- B - Waste Stored
- C - Waste Treated

CHESWICK SITE
CHESWICK PA.
Scale: .083ⁱⁿ = 10ft.
SEPT 68

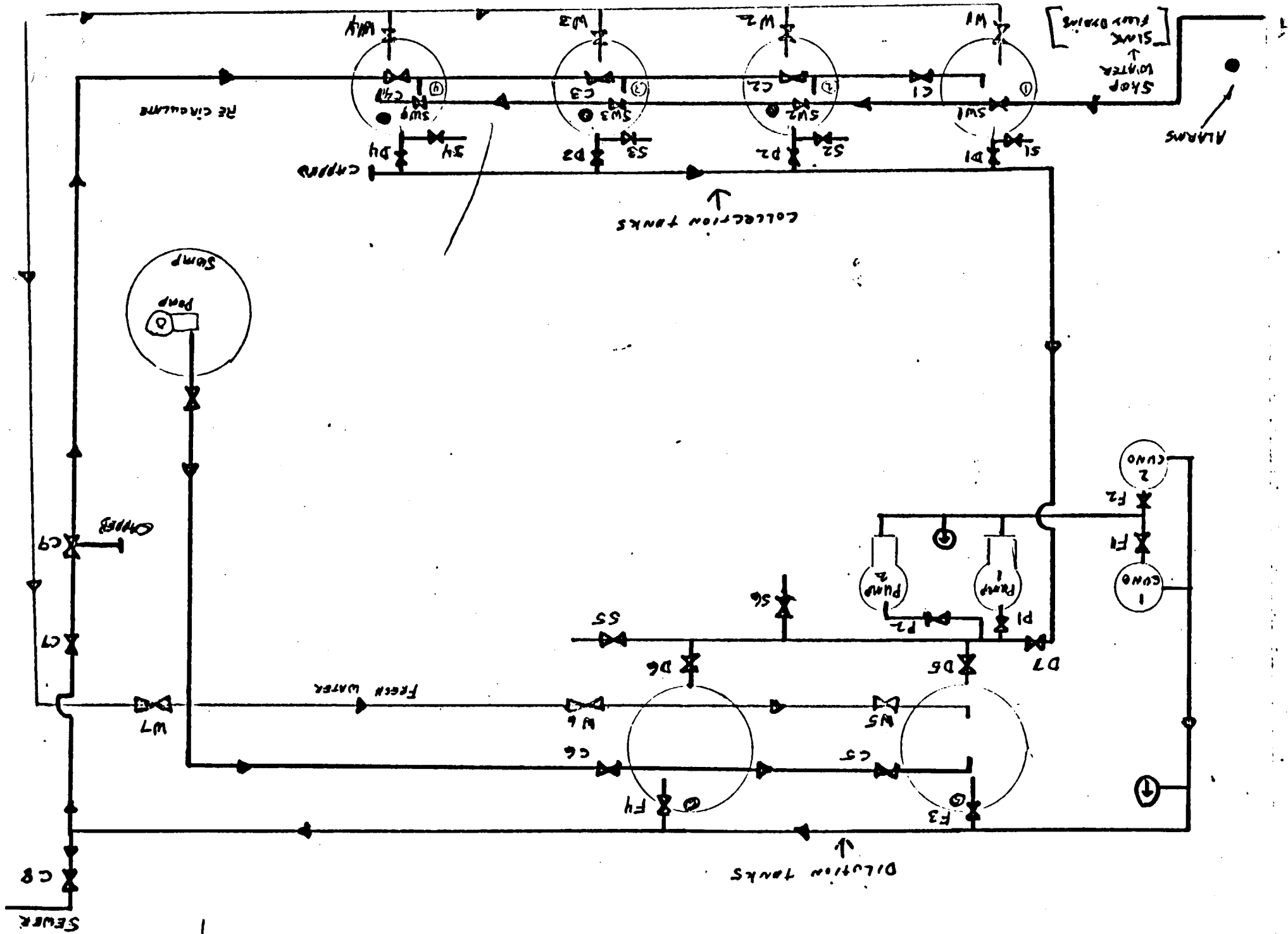

DUCT WASTE SYSTEM
 E.D.L. BILL # 7



WASTE MANAGEMENT PROGRAM
Nuclear Fuel Division, Cheswick
SNM 338
Building 5B

I. Waste Identification and Characterization

A. Radioactive waste is generated in Building 5B, a typical manufacturing building consisting of a steel framework with brick sidewalls. Low level contaminated solid waste is stored outside to the west of Building 5B. The retention system for liquid waste is underground and also to the west of Building 5B. Building 5B, the storage area, and the liquid waste facility are surrounded by an 8 foot security fence. (See Attachment 1.)

B. 1. There are no manufacturing processes that by themselves generate radioactive waste. Radioactive waste is generated primarily from the cleaning of tools and equipment, from the discard of worn tools, obsolete equipment, and non reuseable containers, and from various devices required by the health and safety program.

2. Waste Categorization

a. Solid

- 1) Plastic gloves and paper towels required by the health and safety program.
- 2) Used absolute filters.
- 3) Fiberboard containers used to store and ship UO₂ powder.
- 4) Obsolete processing equipment.
- 5) Protective clothing worn by personnel.
- 6) Miscellaneous floor sweepings, rags, wood, and metal which are contaminated by radioactive materials.

I. Waste Identification and Characterization

B. 2. Waste Categorization (continued)

b. Liquid

- 1) Equipment and floor wash water.
- 2) Coolant water from grinding operations.

c. Gas

- 1) Exhaust air.

3. Identity

- a. The contamination in the solid waste is in the form of low enriched, less than 5% isotope U₂₃₅, Uranium Dioxide Powder. The average amount of UO₂ contained per DOT approved drum or carton is 45 grams. It is estimated the average amount of UO₂ per laundry bag is less than one gram.

There is no permanent storage of solid waste on site. Waste is only held long enough to accumulate sufficient quantities for truck shipment to a commercial waste disposal company.

- b. The liquid waste consists of varying concentrations of low enriched, less than 5% isotope U₂₃₅, uranium dioxide powder suspended in water. Liquid waste is held in quarantine tanks until measured and released.
- c. The exhaust air contains low concentrations of low enriched, less than 5% isotope U₂₃₅, uranium dioxide powder.

4. Quantity

- a. Approximately 10,000 ft³ of solid waste is generated per year.
- b. In 1970, 3,200 grams of uranium were accounted for in liquid waste.
- c. In 1970, 38 ± 38 grams of UO₂ were discharged in exhaust air.

WASTE MANAGEMENT PROGRAM
Nuclear Fuel Division, Cheswick
SNM 338
Building 5B

I. Waste Identification and Characterization

A. Radioactive waste is generated in Building 5B, a typical manufacturing building consisting of a steel framework with brick sidewalls. Low level contaminated solid waste is stored outside to the west of Building 5B. The retention system for liquid waste is underground and also to the west of Building 5B. Building 5B, the storage area, and the liquid waste facility are surrounded by an 8 foot security fence. (See Attachment 1.)

B. 1. There are no manufacturing processes that by themselves generate radioactive waste. Radioactive waste is generated primarily from the cleaning of tools and equipment, from the discard of worn tools, obsolete equipment, and non reuseable containers, and from various devices required by the health and safety program.

2. Waste Categorization

a. Solid

- 1) Plastic gloves and paper towels required by the health and safety program.
- 2) Used absolute filters.
- 3) Fiberboard containers used to store and ship UO₂ powder.
- 4) Obsolete processing equipment.
- 5) Protective clothing worn by personnel.
- 6) Miscellaneous floor sweepings, rags, wood, and metal which are contaminated by radioactive materials.

I. Waste Identification and Characterization

B. 2. Waste Categorization (continued)

b. Liquid

- 1) Equipment and floor wash water.
- 2) Coolant water from grinding operations.

c. Gas

- 1) Exhaust air.

3. Identity

- a. The contamination in the solid waste is in the form of low enriched, less than 5% isotope U₂₃₅, Uranium Dioxide Powder. The average amount of UO₂ contained per DOT approved drum or carton is 45 grams. It is estimated the average amount of UO₂ per laundry bag is less than one gram.

There is no permanent storage of solid waste on site. Waste is only held long enough to accumulate sufficient quantities for truck shipment to a commercial waste disposal company.

- b. The liquid waste consists of varying concentrations of low enriched, less than 5% isotope U₂₃₅, uranium dioxide powder suspended in water. Liquid waste is held in quarantine tanks until measured and released.
- c. The exhaust air contains low concentrations of low enriched, less than 5% isotope-U₂₃₅, uranium dioxide powder.

4. Quantity

- a. Approximately 10,000 ft³ of solid waste is generated per year.
- b. In 1970, 3,200 grams of uranium were accounted for in liquid waste.
- c. In 1970, 38 ± 38 grams of UO₂ were discharged in exhaust air.

I. Waste Identification and Characterization

B. 5. Inventory

- a. The inventory of solid waste varies up to 3000 ft³.
- b. The tanks in the liquid waste treatment pit have a capacity of 14,000 gallons.

II. Treatment and Handling

- A. The liquid waste in the retention tanks is agitated to obtain a homogeneous mixture. One quart samples are collected from two locations on the tank.

Based upon the radiometric analysis, the liquid is pumped to another retention tank. In this tank the liquid is diluted to comply with state and federal limits.

The diluted waste is discharged through 200, 60 and 5 micron filter stages to the municipal sewer.

- B. See attachments 2 and 3.
- C. None

III. Disposition

A. Categories

1. Liquid waste is monitored, filtered and discharged to the municipal sewer, which feeds into a municipal treatment plant.
2. Solid contaminated waste is transferred to the Nuclear Engineering Company, a commercial nuclear waste disposal firm.

B. Concentrations

1. The average liquid concentrations prior to filtration in 1970 was $2.37 \times 10^{-5} \mu \text{ Ci/cc}$. The maximum concentration was $3 \times 10^{-4} \mu \text{ Ci/cc}$.
2. The average daily air concentration in 1970 was $1.14 \times 10^{-13} \mu \text{ Ci/cc}$. The maximum concentration was $4.55 \times 10^{-13} \mu \text{ Ci/cc}$.

III. Disposition

C. Surrounding Area

The plant site is located approximately 18 miles northeast of Pittsburgh, Pennsylvania, in semirural Harmar Township, near the town of Cheswick. The site contains 125 acres on a nearly level plateau about 200 ft. above the nearby Allegheny River. The community surrounding the site consists of single family homes and small industrial plants. The approximate population of the area is 3000. The mean seasonal meteorological conditions* are as follows.

| | Spring | Summer | Winter |
|---------------------|--------|--------|--------|
| Temperature (°F) | 50 | 67 | 31 |
| Mean Wind Direction | W/SW | W/SW | W/SW |
| Humidity (percent) | 50 | 52 | 65 |
| Rainfall (inches) | 3.08 | 3.88 | 2.75 |

* Source - National Weather Service

IV. Future Plans

A 70 micron self cleaning filter is being added to the liquid waste treatment stream. In addition, a filtering system ahead of the retention tanks is being designed for the major contributor of liquid waste. These systems should be complete by the spring of 1972.

The major contributor of solid waste, the fiber board containers used to store and ship UO₂ powder, will be phased out by the end of 1972. They will be replaced with reuseable containers.

October 1, 1971

ATTACHMENT 1

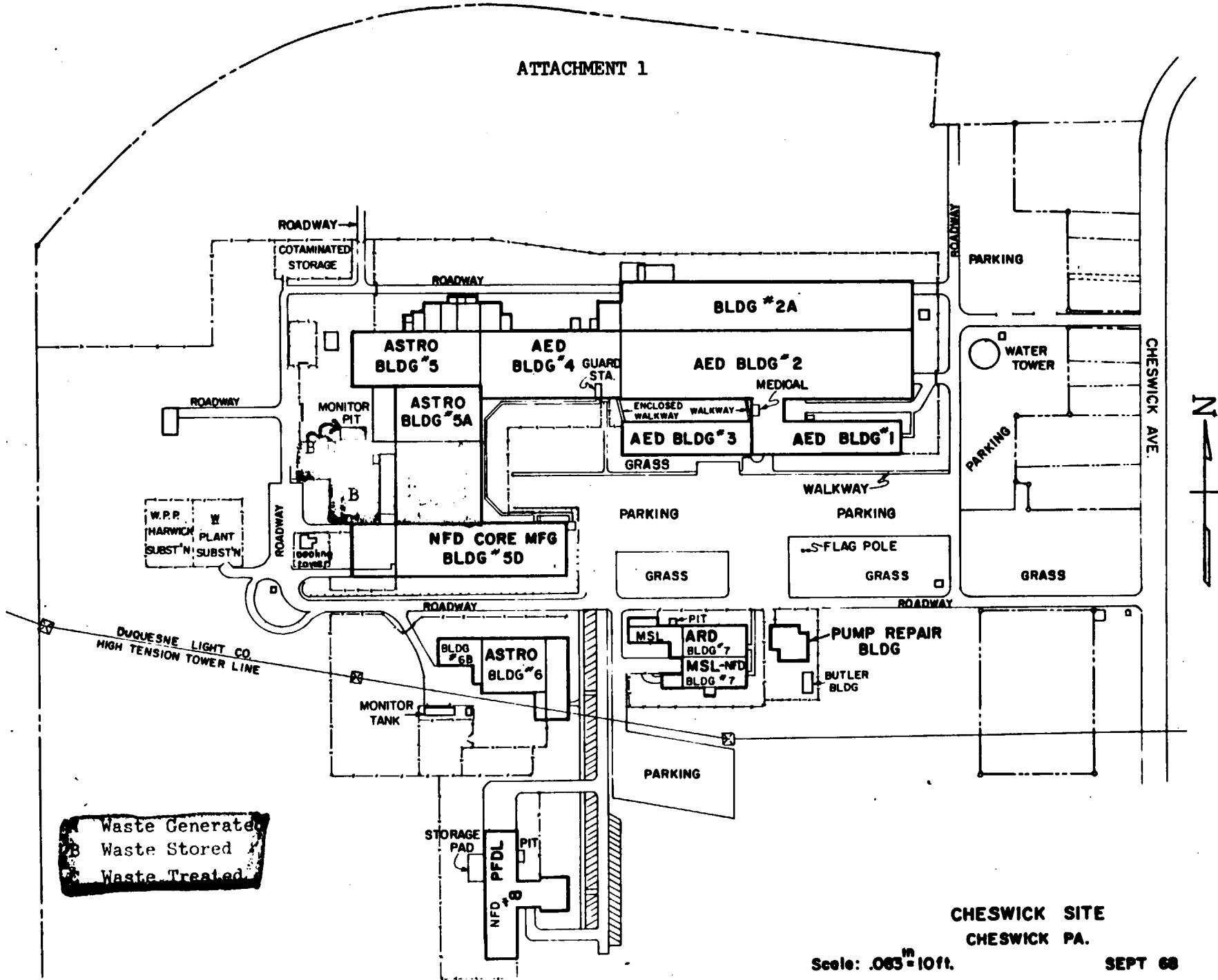

Waste Generated
Waste Stored
Waste Treated

CHESWICK SITE
CHESWICK PA.

Scale: .063" = 10ft.

SEPT 68

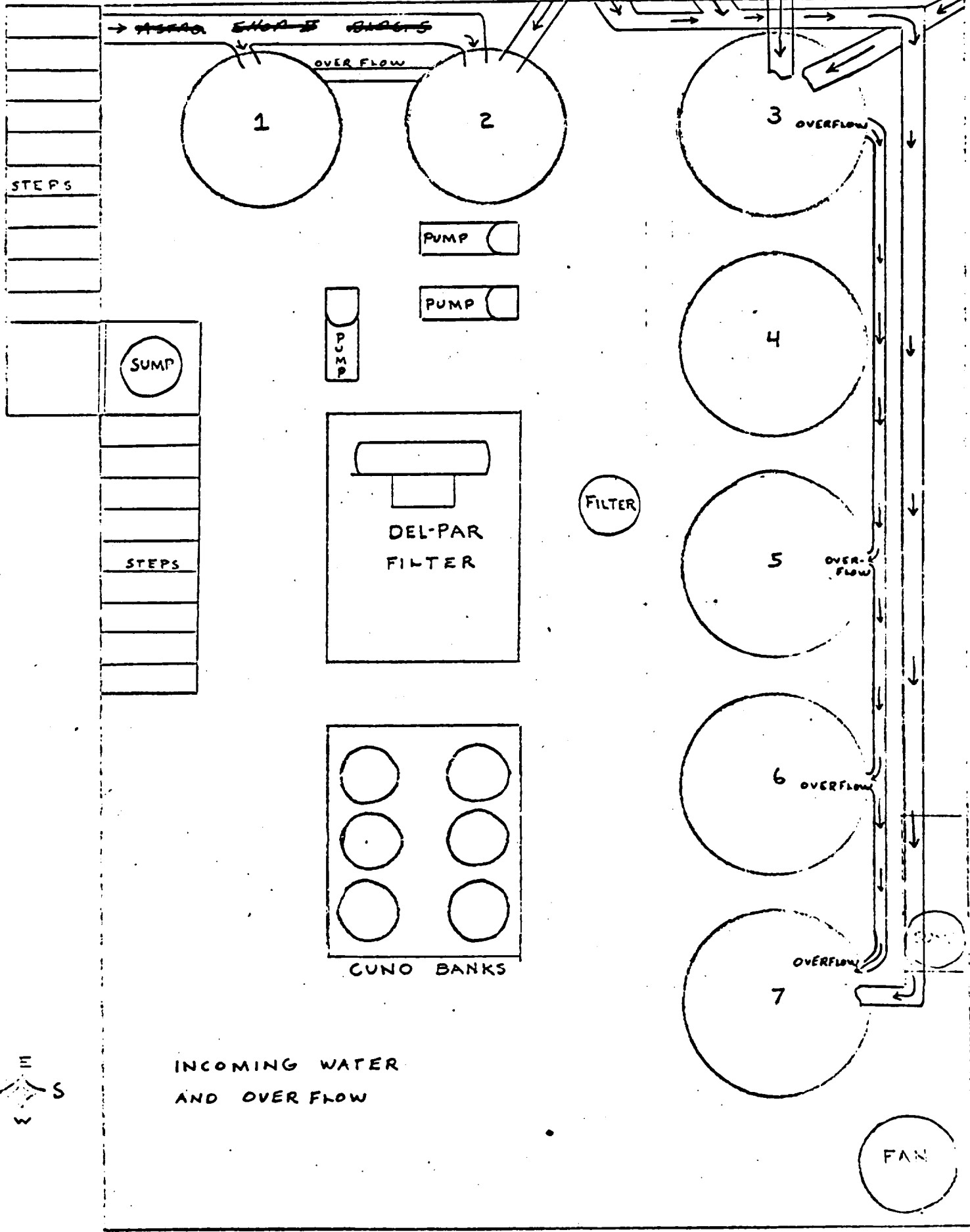

INCOMING WATER
AND OVER FLOW



ATTACHMENT 3

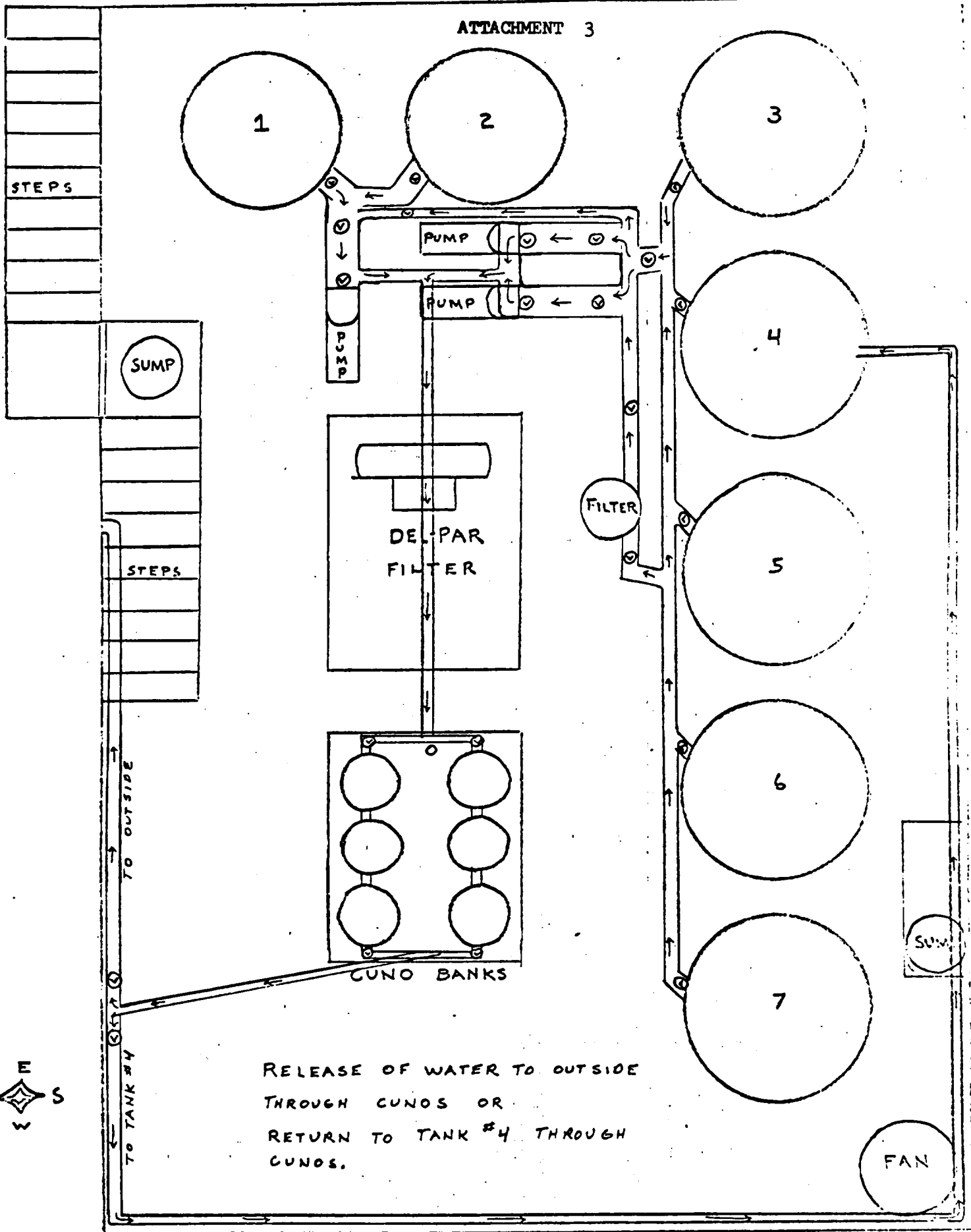

RELEASE OF WATER TO OUTSIDE
 THROUGH CUNOS OR
 RETURN TO TANK #4 THROUGH
 CUNOS.

Description of Waste Management Program

Westinghouse Nuclear Fuel Division

Columbia Plant, Docket 70-1151, SNM 1107

I. Waste Identification and Characterization

- A. Radioactive wastes are generated in the Manufacturing Plant in processes where UF_6 is converted to UO_2 ; UO_2 is milled, prepared for pressing, and pressed into pellets; and pellets are sintered, sized, and loaded into fuel tubes. Following encapsulation in the fuel tubes the manufacturing processes in the fabrication of fuel assemblies for power reactors do not result in radioactive waste.

The areas and buildings where radioactive wastes are generated, stored, and treated are shown in Figure 1.

- B. A schematic diagram of the processes which generate radioactive waste and the waste categorization is shown in Figure 2. The primary wastes result from the chemical conversion of UF_6 to UO_2 and are identified as "Liquid Process Waste" and "Process Gaseous Effluents". Treatment of the liquid process waste results in a solid CaF_2 waste. The "Solid Contaminated Waste", "Controlled Liquid Waste", and "Plant & Lab Gaseous Effluents" are the result of the general operation and include such items as baled waste, sink and shower drains, lab hoods, and general plant air which is discharged from the sintering furnace area. The chemical forms in the waste are primarily UO_2F_2 , ADU, and uranium oxides.

B. (continued)

The quantity and concentrations of each gaseous effluent stream is shown in Table 1.

The current generation rate of the liquid process waste is 12,000 to 15,000 gallons per day. The current generation rate of the controlled liquid waste is approximately 4,000 gallons per day. The current rate of solid waste generation is 1000 cubic feet per month.

The approximate inventory of stored liquid waste is 2,000,000 gallons with a concentration in the range of $2 - 3 \times 10^{-5}$ uCi/ml. The approximate inventory of baled waste is 1000 cubic feet containing 60 millicuries. The approximate inventory of solid CaF₂ waste is 10,000 cubic feet with an average concentration of 2 uCi/pound (dried) or approximately 100 millicuries.

II. Treatment and Handling

A. Process Gaseous Effluents

Effluents from the vaporization, hydrolysis, calcining and recycling operations pass through water scrubbers having an efficiency in the range of 99% for particles of .5 to 1 micron size. The remainder of the process exhausts pass through HEPA filters prior to exhaust. Each effluent stream is continuously sampled. In so far as possible, isokinetic sampling techniques are used.

B. Plant and Lab Gaseous Effluents

The primary plant air is released through HEPA filter houses located above the sintering furnaces. The Health Physics Lab hood exhaust is equipped with a HEPA filter while the Chemistry Laboratory hoods exhaust directly to the atmosphere. The remainder of the controlled area room vents exhaust directly to the atmosphere. Each exhaust or vent is continuously sampled using isokinetic sampling techniques in so far as possible.

C. Controlled Liquid Waste

These liquid effluents are filtered through 1 micron filters and quarantined in 2000 gallon tanks where they are sampled to assure that the concentration is less than MPC prior to release. If required, the liquids can be recycled through filters or transferred to the process waste stream for removal of soluble uranium.

D. Liquid Process Waste

The process waste streams pass through ion exchange columns and 1 micron filters and are collected in quarantine tanks. The tanks are analyzed and, if the concentration is less than MPC, released on a batch basis to the waste treatment facility. The waste treatment facility process is shown in Figure 3. The capacities of these holding ponds are as follows:

| | |
|------------------|-------------------|
| Holding Basin - | 420,000 gallons |
| Settling Basin - | 1,623,000 gallons |
| South Lagoon - | 167,500 gallons |
| North Lagoon - | 153,000 gallons |

D. (continued)

The liquid waste is discharged from the North and South Lagoons on a batch basis after sampling indicates that the applicable discharge limits are satisfied.

III. Disposition

A. Gaseous Waste

The process, plant, and laboratory gaseous effluents are released to the atmosphere through vents or stacks on the manufacturing plant roof. The 1970 discharge data for each of these vents is given in Table I. Not all of these vents were in operation throughout the year so the averages and maximums are given for the period of operation.

The quantities of radioactive material discharged from all of these stacks are added to get a single discharge quantity. A roof top release dispersion equation is used to obtain the maximum ground level concentration which is applicable to the restricted area boundary. Based on these calculations, the average concentration in unrestricted areas in 1970 was 1×10^{-13} uCi/ml and the maximum weekly average was 5.5×10^{-13} uCi/ml. The total quantity released in the gaseous effluents in 1970 was 9.2 millicuries.

B. Liquid Waste

The process liquid waste and controlled liquid waste are released on a batch basis after it is determined that the concentration is less than 3×10^{-5} uCi/ml. This water is diluted with the

B. (continued)

overflow water from the sanitary lagoon and pumped to the Congaree River. This discharge is shown in Figure 3. The total quantity discharged in 1970 was 226 millicuries and the total water was 186,000,000 gallons. This is an average concentration of 3.2×10^{-7} uCi/ml and the maximum concentration, assuming no dilution from the sanitary lagoon, is 3×10^{-5} uCi/ml.

C. Solid Waste

The solid contaminated waste from the process is transferred to a commercial waste disposal company. The solid CaF_2 waste resulting from the waste treatment process is being held in long term storage.

D. Area Description and Environmental Data

A site plan of the 1140 acre site is shown in Figure 5 and the area is shown in Figure 4. This is a rural area. Within a 5 mile radius of the site, the population density is estimated as 31 persons per square mile. However, due to the river and lowlands, the majority of the population is in the northeast half of the circle.

The primary land use is for timber and pulp wood production or farming. The chief crops are soy beans, cotton, corn and garden vegetables.

The meteorological data is given in the U. S. Department of Commerce, 1970 Annual Summary for Columbia, South Carolina, which

D. (continued)

is included as Attachment 1.

The mean seasonal flow of the Congaree River is given in U. S. Department of Interior reports which are included in Attachment 2.

IV. Future Plans

Filter houses have been installed on the primary plant air exhausts in the sintering furnace area. With the large volume of air, this was the greatest source of activity release although this source did not have the highest concentrations.

Additional ventilation system improvements are being designed, and are shown on a schematic diagram in Figure 6. This system will provide additional pick up points within the plant process area and provide scrubbers where gases or moisture dictate. All of the exhausts in the controlled area including the existing and additional scrubber exhaust will pass through a new additional HEPA filter house. Thus all of the effluents from the controlled area will be HEPA filtered and some of the process exhausts will also be scrubbed prior to release. With these improvements, it is expected that the average concentrations at the point of release on the roof will be less than the unrestricted area MPC given in 10 CFR20.

This system is scheduled to be installed by the end of 1971 and should be tested and in operation during the first quarter of 1972.

WASTE STORAGE AND TREATMENT FACILITY LOCATIONS

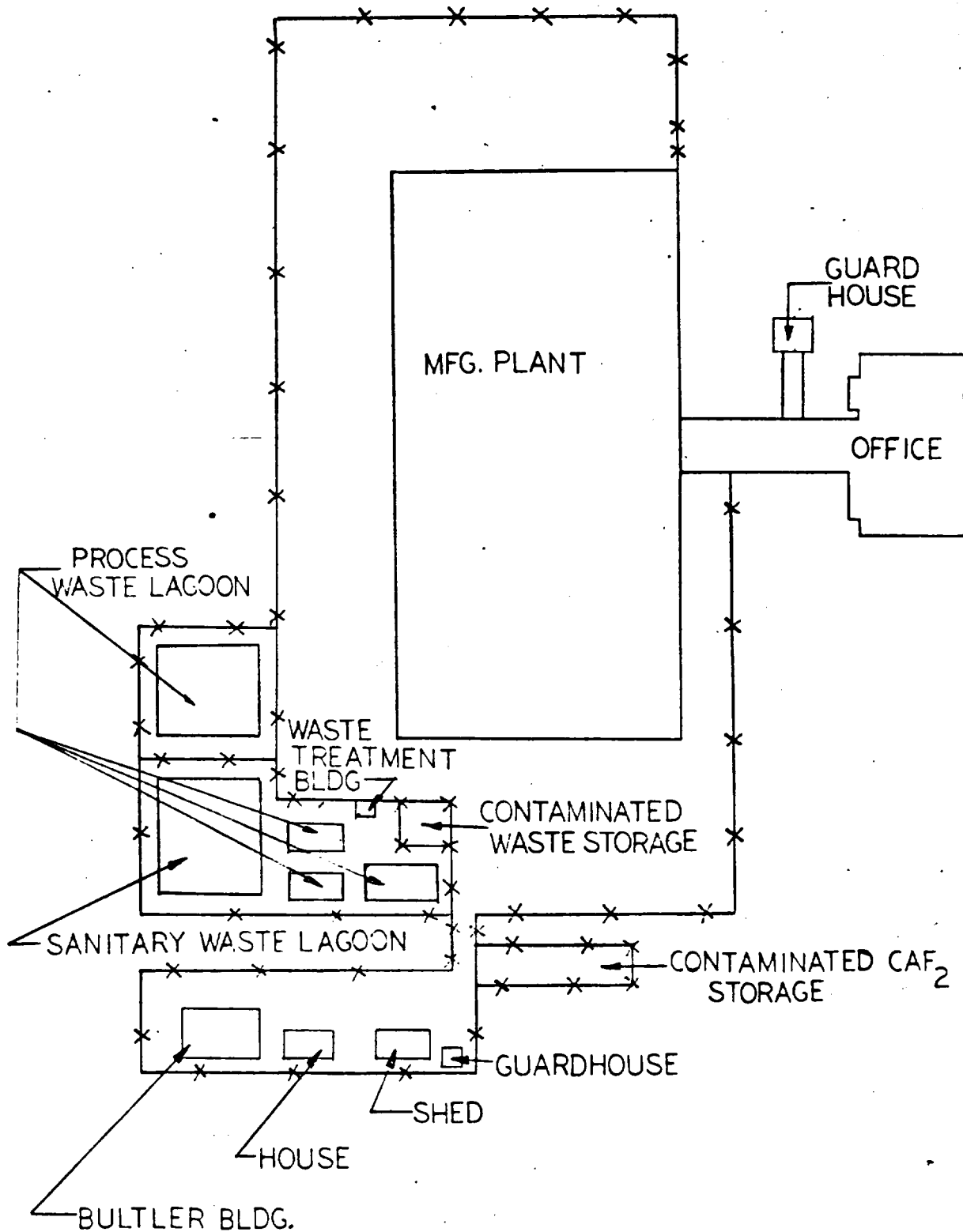

PROCESS SCHEMATIC WITH WASTE CATEGORIZATION

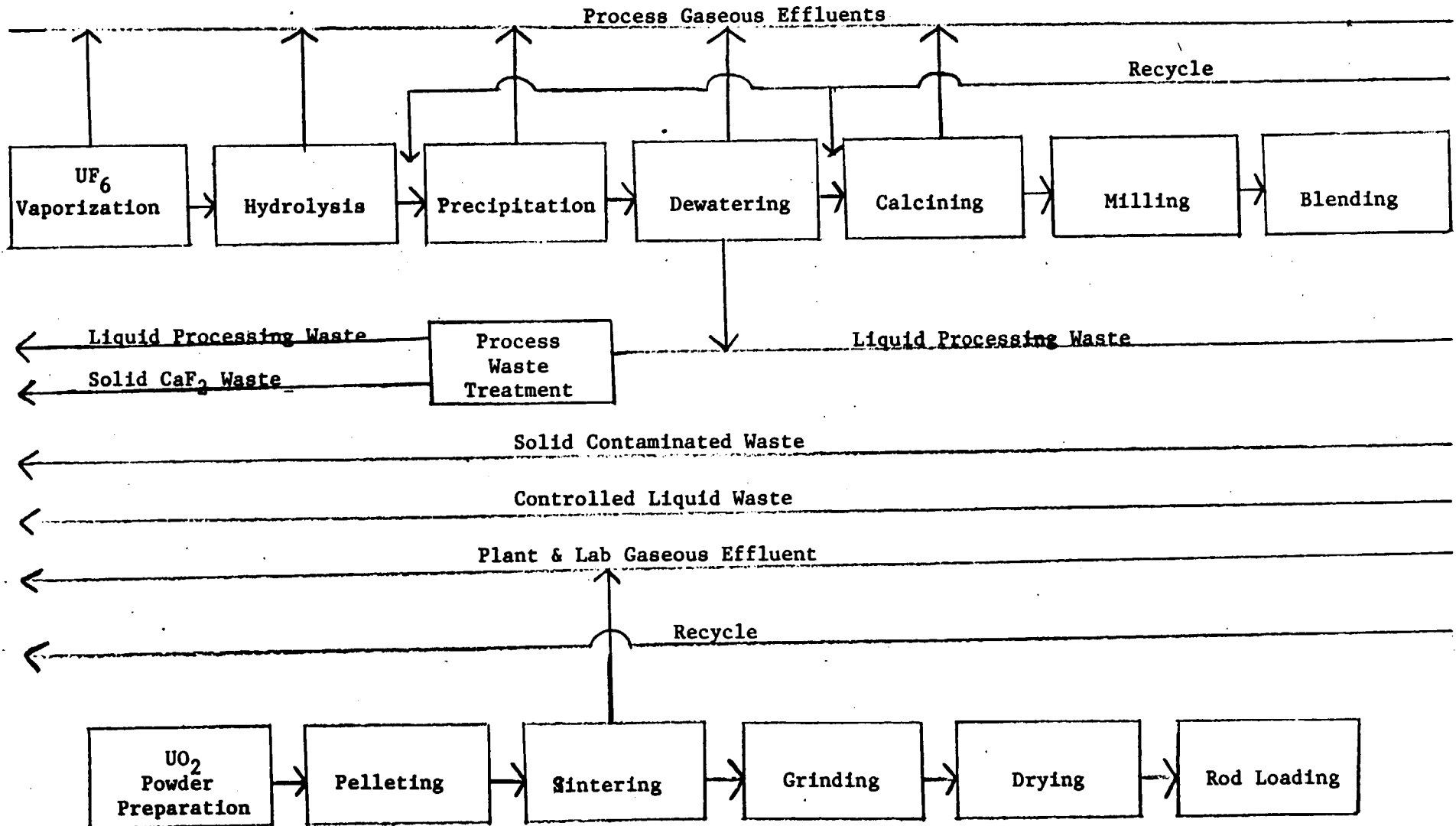

WESTINGHOUSE ELECTRIC CORPORATION

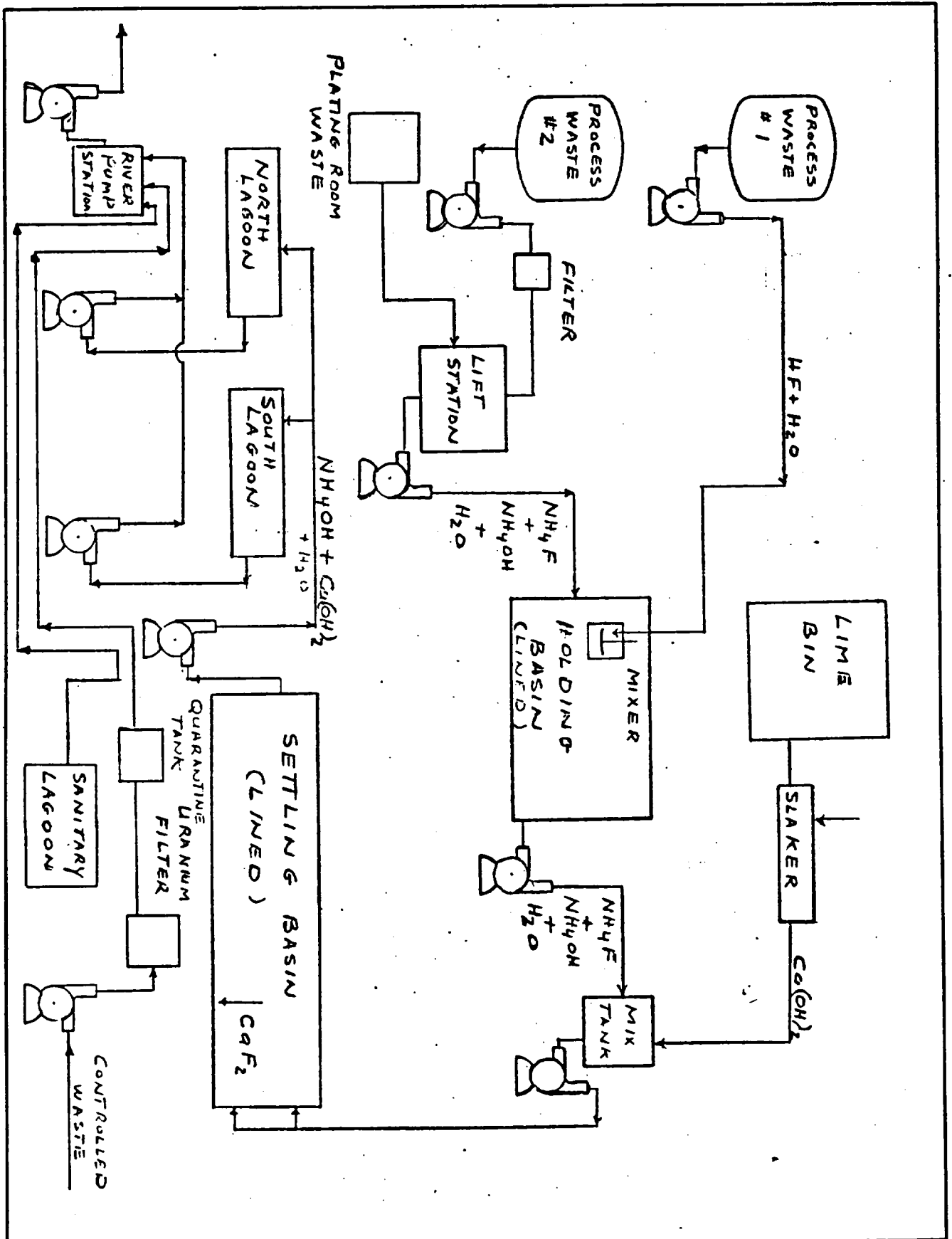

Figure 3

Docket 70-1151, SNM 1107

WASTE TREATMENT PROCESS
7/31/71

TJC

Figure 4

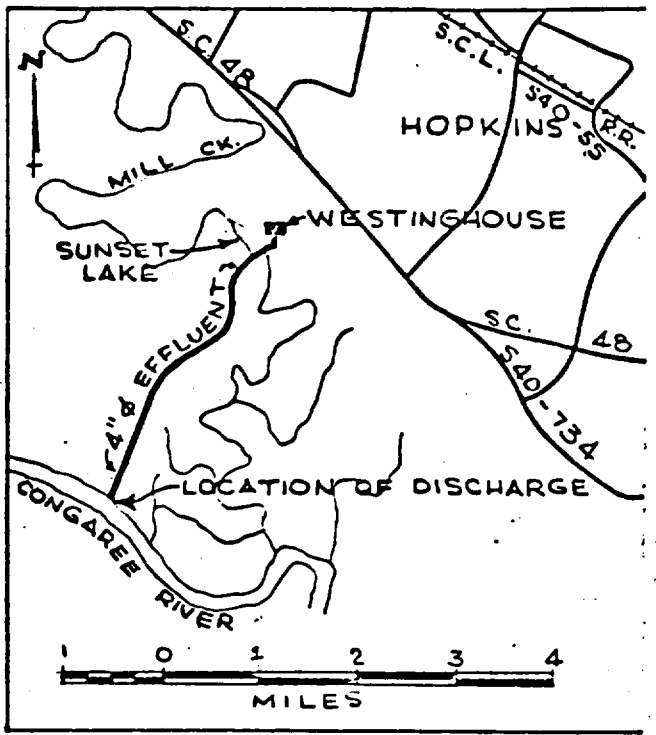
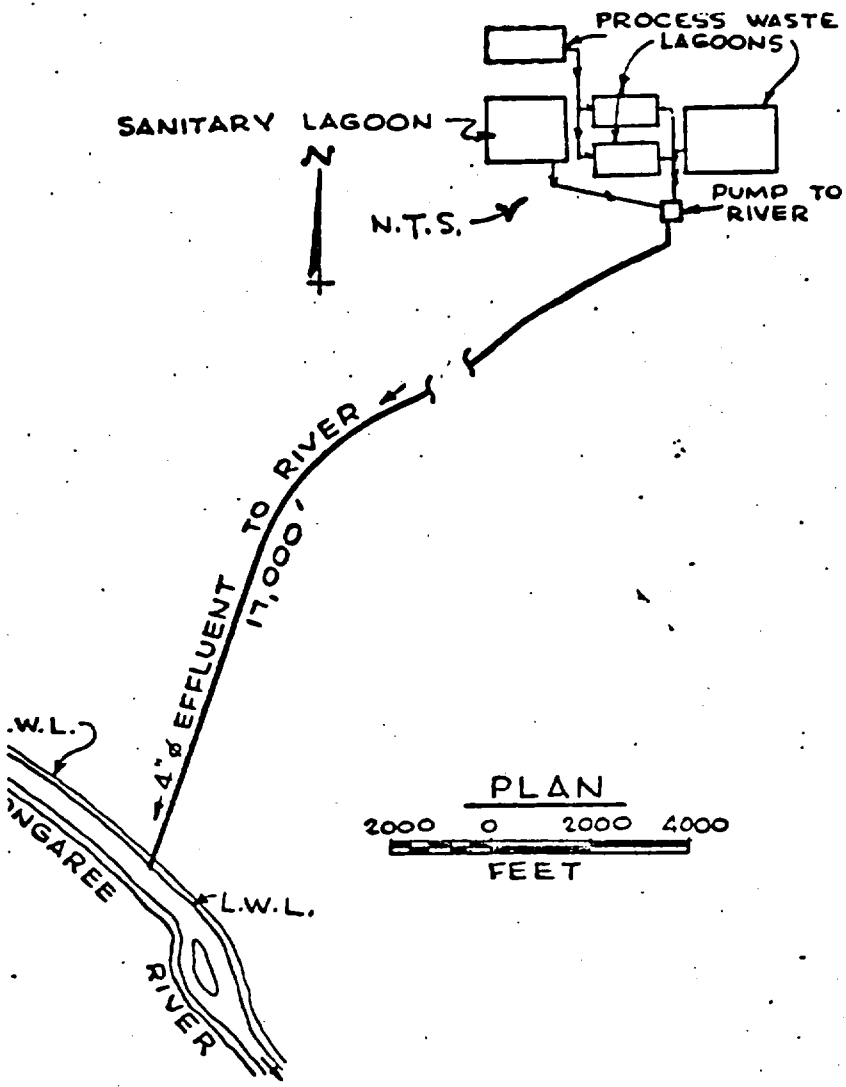

TRACED FROM RICHLAND COUNTY MAP BY SOUTH CAROLINA HWY. DEPT.

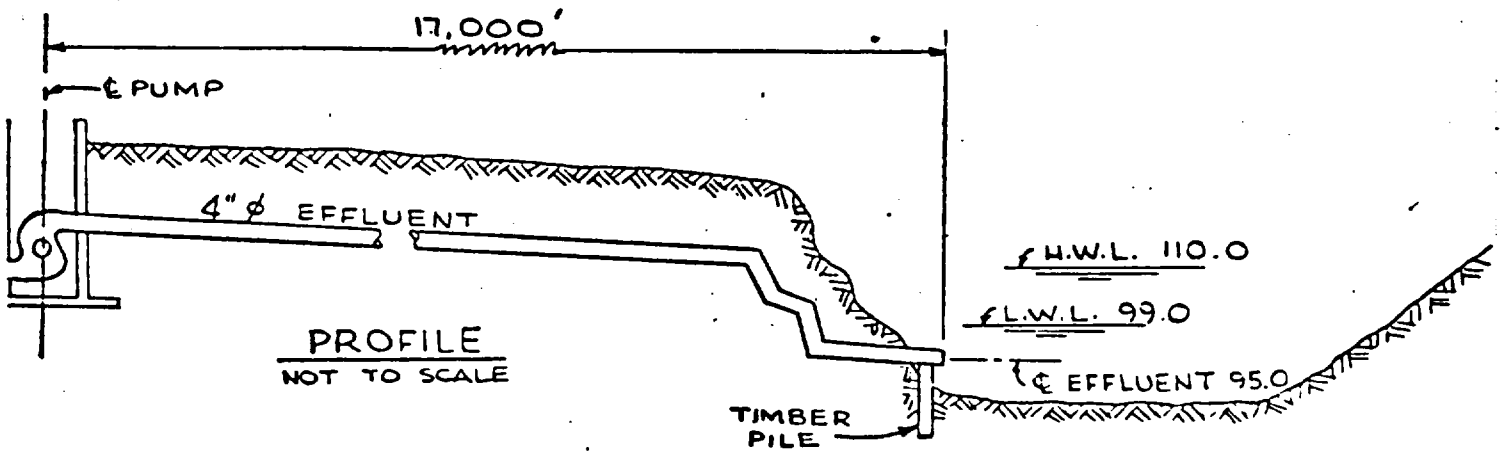

EXISTING 4" SEWER LINE FROM WESTINGHOUSE NEAR COLUMBIA SOUTH CAROLINA. COUNTY OF RICHLAND

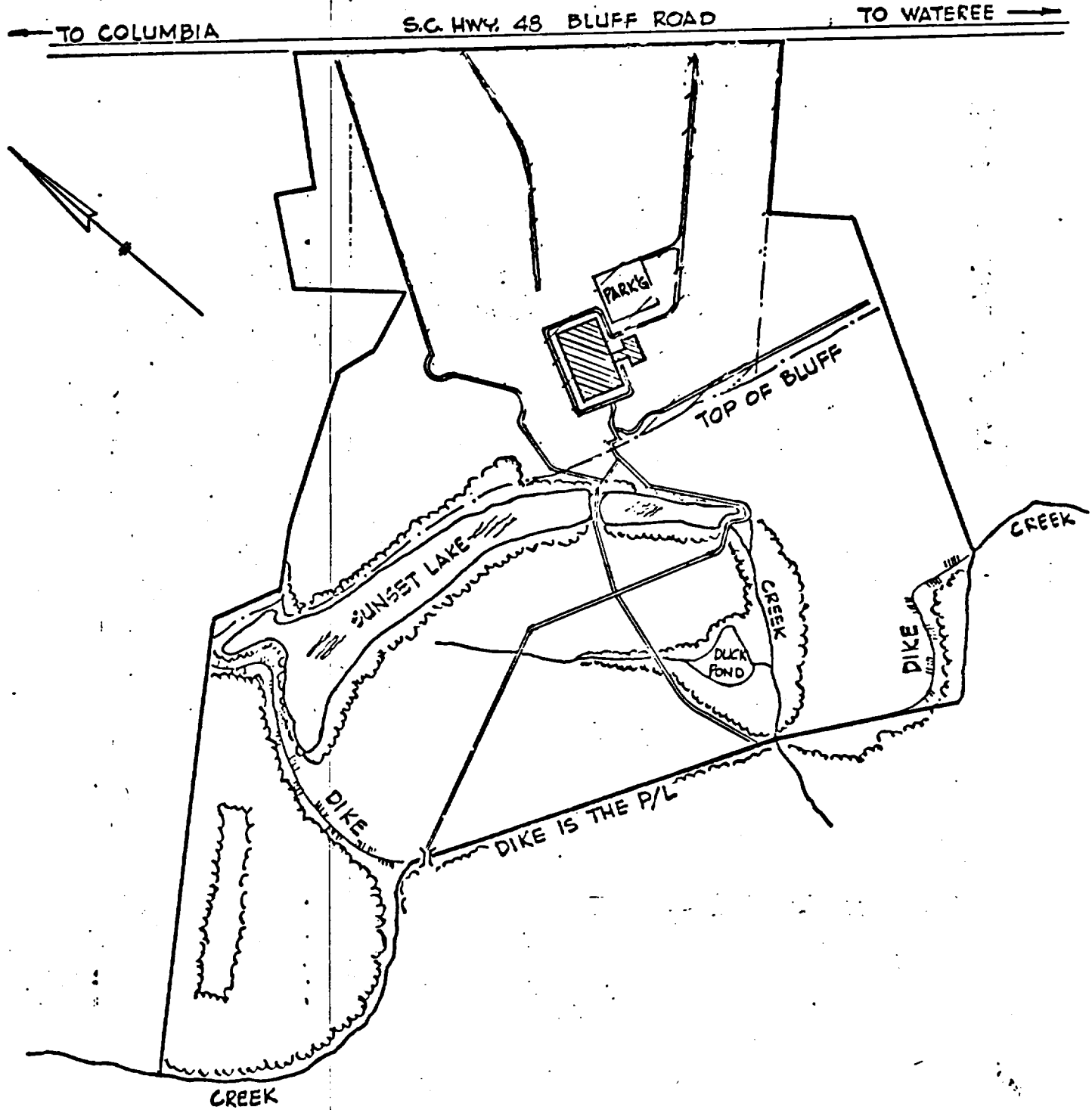

SITE PLAN
OF WESTINGHOUSE PROPERTY

Improved Ventilation System Schematic

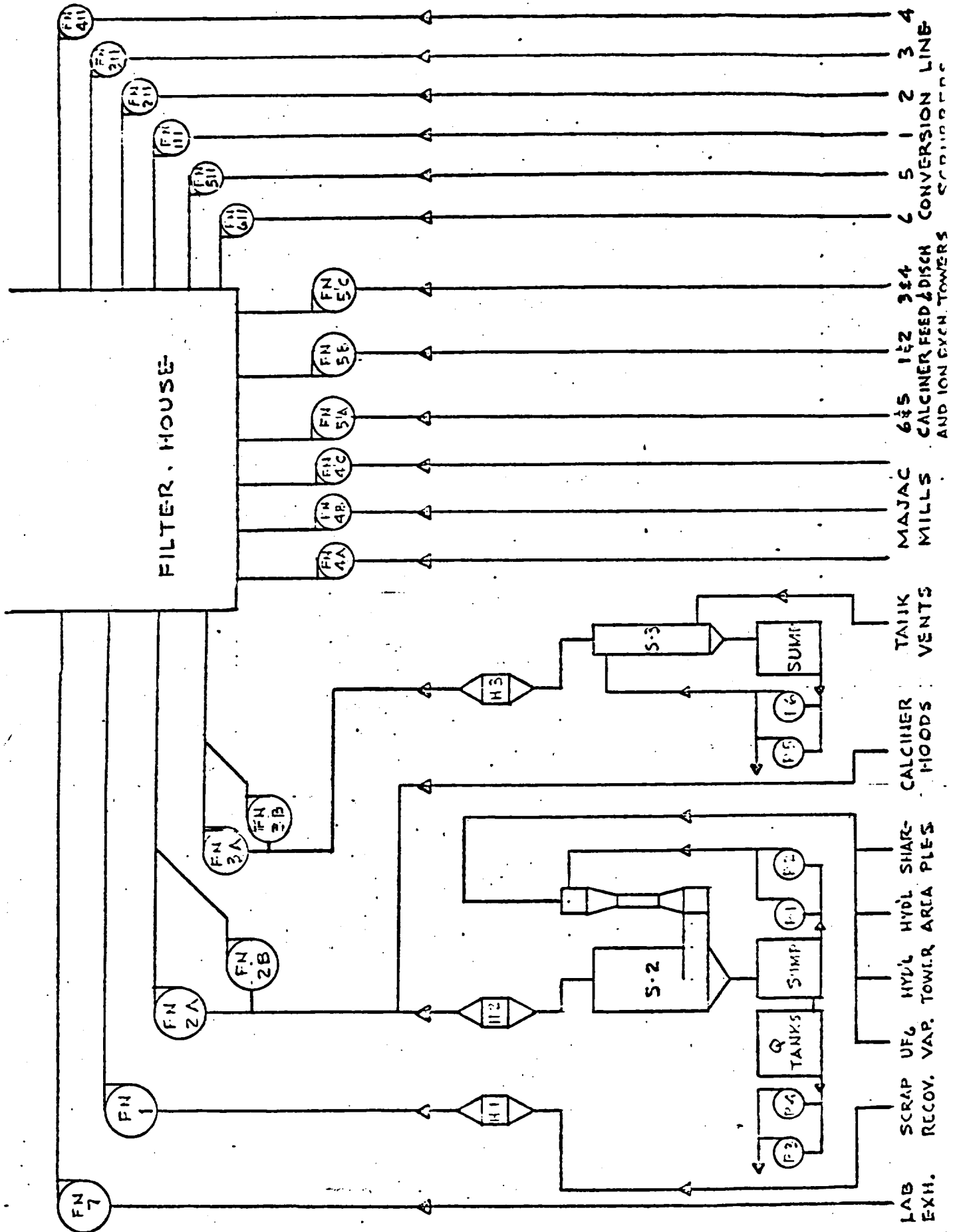

1970 GASEOUS WASTE DISCHARGE SUMMARY

| <u>Effluent Stream</u> | <u>Flow Rate</u> | <u>Avg. Activity</u> | <u>Max. Weekly Discharge</u> | <u>Total Discharge</u> |
|--|------------------------------------|-------------------------------|--------------------------------|------------------------|
| <u>Process Gaseous Effluents:</u> | | | | |
| Aux. Scrubber | 3.23 x 10 ¹⁰ ml/week | 32 x 10 ⁻¹² uCi/ml | 160 x 10 ⁻¹² uCi/ml | 31 uCi |
| Line 1 & 2 tank vents | 5.07 x 10 ¹⁰ " | 25.6 " | 120 " | 40.2 " |
| Line 1 & 2 dewatering vents | 2.53 x 10 ¹¹ " | 49.6 " | 640 " | 389.0 " |
| Line 1 Scrubber | 1.14 x 10 ⁹ " | 30 " | 110 " | .92" |
| Line 2 Scrubber | 8.4 x 10 ⁹ " | 52.8 " | 660 " | 13.7 " |
| Recycle Scrubber | 5.1 x 10 ¹¹ " | 3.5 " | 9.6 " | 30.3 " |
| <u>Plant & Lab Gaseous Effluents:</u> | | | | |
| Main ventilation over scintering furnace (9fans): | | | | |
| Prior to installation of filter houses | 5.7 x 10 ¹² ml/fan/week | 10 " | 86 " | 7797.0 " |
| After installation of filter houses 8/70 | 5 x 10 ¹² " | 2 " | 26 " | 348.0 " |
| Health Physics Lab Hood | 3.56x 10 ¹¹ ml/week | .93 " | 3.9 " | 7.9 " |
| Chem Lab Hood 1 | 2.86x 10 ¹¹ " | .81 " | 4.8 " | 5.6 " |
| Chem Lab Hood 2 | 2.86x 10 ¹¹ " | 1.0 " | 4.9 " | 6.6 " |
| Chem Lab Hood 3 | 2.86x 10 ¹¹ " | 1.1 " | 3.1 " | 7.6 " |
| Chem Lab Hood 4 | 2.86x 10 ¹¹ " | .84 " | 5.1 " | 5.8 " |
| Chem Lab Hood 5 | 2.86x 10 ¹¹ " | .91 " | 3.7 " | 6.2 " |
| Chem Lab Hood 6 | 6.48x 10 ¹¹ " | 1.2 " | 3.4 " | 18.7 " |
| Air Compressor Room | 2.86x 10 ¹² " | 3.0 " | 9.9 " | 205.9 " |
| Boiler Room | 2.86x 10 ¹² " | 2.7 " | 7.4 " | 185.3 " |
| #1 Calciner Combustion Gas | 8.54x 10 ¹⁰ " | 2.8 " | 13.0 " | 5.5 " |
| #2 Calciner Combustion Gas | 8.54x 10 ¹⁰ " | 3.5 " | 16.0 " | 6.9 " |
| Restroom | 5.14x 10 ¹⁰ " | 5.6 " | 44.0 " | 6.6 " |

METEOROLOGICAL DATA FOR THE CURRENT YEAR

Station: COLUMBIA, SOUTH CAROLINA COLUMBIA METROPOLITAN AIRPORT Standard time zone: EASTERN Latitude: 33° 37' N Longitude: 81° 07' W Elevation (ground): 213 feet Year: 1970

| Month | Temperature | | | | Precipitation | | | | Relative humidity | | | | Wind | | | | Number of days | | | | | | | | | | | | | | |
|-------|---------------|---------------|---------------|---------------|---------------|--------|-------------------|------|-------------------|------|-----------|-----------|--------------|-----------|-------------------|-----------|-------------------|-----------|---------------|-------|-------------------|--------|------------------|-------------------|------------------|---------------|---------------|---------------|---------------|---|---|
| | Averages | | Extremes | | Total | | Snow, ice pellets | | Hour | | Resistant | | Fastest mile | | Average sky cover | | Sunrise to sunset | | Precipitation | | Snow, ice pellets | | Thunderstorms | | Heavy fog | | Maximum | | Minimum | | |
| | Daily maximum | Daily minimum | Daily maximum | Daily minimum | Total | 24 hrs | 24 hrs | Date | Hour | Hour | Hour | Direction | Speed | Direction | Speed | Direction | Speed | Direction | Speed | Clear | Partly cloudy | Cloudy | 0.1 inch or more | Snow, ice pellets | 1.0 inch or more | 90° and above | 32° and below | 90° and above | 32° and below | | |
| | | | | | | | | | | | | | | | | | | | | | | | | | | | | | | | |
| JAN | 35.6 | 24.2 | 59.3 | 13.9 | 2.2 | 0.0 | 1.0 | 1/1 | 89 | 88 | 89 | 27 | 2.8 | 7.1 | 20 | 0 | 85 | 9 | 0 | 0 | 0 | 0 | 0 | 0 | 0 | 0 | 23 | 0 | 0 | 0 | 0 |
| FEB | 38.3 | 27.1 | 58.2 | 19.3 | 0.0 | 0.0 | 0.0 | 0 | 89 | 89 | 89 | 27 | 2.8 | 7.1 | 20 | 0 | 85 | 9 | 0 | 0 | 0 | 0 | 0 | 0 | 0 | 0 | 23 | 0 | 0 | 0 | 0 |
| MAR | 51.4 | 36.4 | 68.3 | 29.2 | 0.0 | 0.0 | 0.0 | 0 | 89 | 89 | 89 | 27 | 2.8 | 7.1 | 20 | 0 | 85 | 9 | 0 | 0 | 0 | 0 | 0 | 0 | 0 | 0 | 23 | 0 | 0 | 0 | 0 |
| APR | 60.9 | 44.1 | 77.1 | 40.2 | 0.0 | 0.0 | 0.0 | 0 | 89 | 89 | 89 | 27 | 2.8 | 7.1 | 20 | 0 | 85 | 9 | 0 | 0 | 0 | 0 | 0 | 0 | 0 | 0 | 23 | 0 | 0 | 0 | 0 |
| MAY | 71.9 | 51.6 | 87.3 | 50.0 | 0.0 | 0.0 | 0.0 | 0 | 89 | 89 | 89 | 27 | 2.8 | 7.1 | 20 | 0 | 85 | 9 | 0 | 0 | 0 | 0 | 0 | 0 | 0 | 0 | 23 | 0 | 0 | 0 | 0 |
| JUN | 81.0 | 60.5 | 94.0 | 65.0 | 0.0 | 0.0 | 0.0 | 0 | 89 | 89 | 89 | 27 | 2.8 | 7.1 | 20 | 0 | 85 | 9 | 0 | 0 | 0 | 0 | 0 | 0 | 0 | 0 | 23 | 0 | 0 | 0 | 0 |
| JUL | 84.8 | 71.9 | 93.7 | 80.1 | 0.0 | 0.0 | 0.0 | 0 | 89 | 89 | 89 | 27 | 2.8 | 7.1 | 20 | 0 | 85 | 9 | 0 | 0 | 0 | 0 | 0 | 0 | 0 | 0 | 23 | 0 | 0 | 0 | 0 |
| AUG | 84.8 | 71.9 | 93.7 | 80.1 | 0.0 | 0.0 | 0.0 | 0 | 89 | 89 | 89 | 27 | 2.8 | 7.1 | 20 | 0 | 85 | 9 | 0 | 0 | 0 | 0 | 0 | 0 | 0 | 0 | 23 | 0 | 0 | 0 | 0 |
| SEP | 78.3 | 65.3 | 88.1 | 70.0 | 0.0 | 0.0 | 0.0 | 0 | 89 | 89 | 89 | 27 | 2.8 | 7.1 | 20 | 0 | 85 | 9 | 0 | 0 | 0 | 0 | 0 | 0 | 0 | 0 | 23 | 0 | 0 | 0 | 0 |
| OCT | 71.7 | 57.7 | 81.7 | 64.7 | 0.0 | 0.0 | 0.0 | 0 | 89 | 89 | 89 | 27 | 2.8 | 7.1 | 20 | 0 | 85 | 9 | 0 | 0 | 0 | 0 | 0 | 0 | 0 | 0 | 23 | 0 | 0 | 0 | 0 |
| NOV | 64.5 | 50.1 | 73.7 | 58.0 | 0.0 | 0.0 | 0.0 | 0 | 89 | 89 | 89 | 27 | 2.8 | 7.1 | 20 | 0 | 85 | 9 | 0 | 0 | 0 | 0 | 0 | 0 | 0 | 0 | 23 | 0 | 0 | 0 | 0 |
| DEC | 51.9 | 38.6 | 63.0 | 45.2 | 0.0 | 0.0 | 0.0 | 0 | 89 | 89 | 89 | 27 | 2.8 | 7.1 | 20 | 0 | 85 | 9 | 0 | 0 | 0 | 0 | 0 | 0 | 0 | 0 | 23 | 0 | 0 | 0 | 0 |
| YEAR | 70.6 | 51.0 | 84.3 | 64.3 | 31.9 | 0.0 | 1.0 | 23 | 82 | 80 | 81 | 64 | 27 | 1.0 | 6.7 | 35 | 30 | 30 | 30 | 63 | 5.8 | 109 | 100 | 140 | 102 | 92 | 102 | 2 | 67 | 0 | 0 |

NORMALS, MEANS, AND EXTREMES

| Month | Temperature | | | | Precipitation | | | | Relative humidity | | | | Wind | | | | Number of days | | | | | | | | | | | | | |
|-------|---------------|---------------|---------------|---------------|---------------|--------|-------------------|------|-------------------|------|-----------|-----------|--------------|-----------|-------------------|-----------|-------------------|-------|---------------|--------|-------------------|-------------------|------------------|---------------|---------------|---------------|---------------|---------------|---------------|---|
| | Normal | | Extremes | | Normal | | Snow, ice pellets | | Hour | | Resistant | | Fastest mile | | Average sky cover | | Sunrise to sunset | | Precipitation | | Snow, ice pellets | | Thunderstorms | | Heavy fog | | Maximum | | Minimum | |
| | Daily maximum | Daily minimum | Daily maximum | Daily minimum | Total | 24 hrs | 24 hrs | Date | Hour | Hour | Hour | Direction | Speed | Direction | Speed | Direction | Speed | Clear | Partly cloudy | Cloudy | 0.1 inch or more | Snow, ice pellets | 1.0 inch or more | 90° and above | 32° and below | 90° and above | 32° and below | 90° and above | 32° and below | |
| | | | | | | | | | | | | | | | | | | | | | | | | | | | | | | |
| JAN | 35.6 | 24.2 | 59.3 | 13.9 | 2.2 | 0.0 | 1.0 | 1/1 | 89 | 88 | 89 | 27 | 2.8 | 7.1 | 20 | 0 | 85 | 9 | 0 | 0 | 0 | 0 | 0 | 0 | 0 | 23 | 0 | 0 | 0 | 0 |
| FEB | 38.3 | 27.1 | 58.2 | 19.3 | 0.0 | 0.0 | 0.0 | 0 | 89 | 89 | 89 | 27 | 2.8 | 7.1 | 20 | 0 | 85 | 9 | 0 | 0 | 0 | 0 | 0 | 0 | 0 | 23 | 0 | 0 | 0 | 0 |
| MAR | 51.4 | 36.4 | 68.3 | 29.2 | 0.0 | 0.0 | 0.0 | 0 | 89 | 89 | 89 | 27 | 2.8 | 7.1 | 20 | 0 | 85 | 9 | 0 | 0 | 0 | 0 | 0 | 0 | 0 | 23 | 0 | 0 | 0 | 0 |
| APR | 60.9 | 44.1 | 77.1 | 40.2 | 0.0 | 0.0 | 0.0 | 0 | 89 | 89 | 89 | 27 | 2.8 | 7.1 | 20 | 0 | 85 | 9 | 0 | 0 | 0 | 0 | 0 | 0 | 0 | 23 | 0 | 0 | 0 | 0 |
| MAY | 71.9 | 51.6 | 87.3 | 50.0 | 0.0 | 0.0 | 0.0 | 0 | 89 | 89 | 89 | 27 | 2.8 | 7.1 | 20 | 0 | 85 | 9 | 0 | 0 | 0 | 0 | 0 | 0 | 0 | 23 | 0 | 0 | 0 | 0 |
| JUN | 81.0 | 60.5 | 94.0 | 65.0 | 0.0 | 0.0 | 0.0 | 0 | 89 | 89 | 89 | 27 | 2.8 | 7.1 | 20 | 0 | 85 | 9 | 0 | 0 | 0 | 0 | 0 | 0 | 0 | 23 | 0 | 0 | 0 | 0 |
| JUL | 84.8 | 71.9 | 93.7 | 80.1 | 0.0 | 0.0 | 0.0 | 0 | 89 | 89 | 89 | 27 | 2.8 | 7.1 | 20 | 0 | 85 | 9 | 0 | 0 | 0 | 0 | 0 | 0 | 0 | 23 | 0 | 0 | 0 | 0 |
| AUG | 84.8 | 71.9 | 93.7 | 80.1 | 0.0 | 0.0 | 0.0 | 0 | 89 | 89 | 89 | 27 | 2.8 | 7.1 | 20 | 0 | 85 | 9 | 0 | 0 | 0 | 0 | 0 | 0 | 0 | 23 | 0 | 0 | 0 | 0 |
| SEP | 78.3 | 65.3 | 88.1 | 70.0 | 0.0 | 0.0 | 0.0 | 0 | 89 | 89 | 89 | 27 | 2.8 | 7.1 | 20 | 0 | 85 | 9 | 0 | 0 | 0 | 0 | 0 | 0 | 0 | 23 | 0 | 0 | 0 | 0 |
| OCT | 71.7 | 57.7 | 81.7 | 64.7 | 0.0 | 0.0 | 0.0 | 0 | 89 | 89 | 89 | 27 | 2.8 | 7.1 | 20 | 0 | 85 | 9 | 0 | 0 | 0 | 0 | 0 | 0 | 0 | 23 | 0 | 0 | 0 | 0 |
| NOV | 64.5 | 50.1 | 73.7 | 58.0 | 0.0 | 0.0 | 0.0 | 0 | 89 | 89 | 89 | 27 | 2.8 | 7.1 | 20 | 0 | 85 | 9 | 0 | 0 | 0 | 0 | 0 | 0 | 0 | 23 | 0 | 0 | 0 | 0 |
| DEC | 51.9 | 38.6 | 63.0 | 45.2 | 0.0 | 0.0 | 0.0 | 0 | 89 | 89 | 89 | 27 | 2.8 | 7.1 | 20 | 0 | 85 | 9 | 0 | 0 | 0 | 0 | 0 | 0 | 0 | 23 | 0 | 0 | 0 | 0 |
| YEAR | 70.6 | 51.0 | 84.3 | 64.3 | 31.9 | 0.0 | 1.0 | 23 | 82 | 80 | 81 | 64 | 27 | 1.0 | 6.7 | 35 | 30 | 30 | 63 | 5.8 | 109 | 100 | 140 | 102 | 92 | 102 | 2 | 67 | 0 | 0 |

Means and extremes above are from existing and comparable exposures. Annual extremes have been exceeded at other sites in the locality as follows: Highest temperature 107 in June 1954; lowest temperature -2 in February 1899; maximum monthly snowfall 11.8 in February 1899; maximum snowfall 11.7 in February 1914.

- Length of record, years, based on January data. Other months may be for more or fewer years if there have been breaks in the record.
 - Climatological standards normals (1931-1960).
 - Also on earlier dates, months, or years.
 - Trace, as shown too small to measure.
 - Below zero temperatures are recorded in the Normal, Mean, and Extremes table in those records through 1963.
 - ± 8° at Abilene station.
- Solar radiation data are the averages of direct and diffuse radiation on a horizontal surface. The lagrange correction on data per square centimeter.
- Sky cover is expressed in a range of 0 for no clouds or obscuring phenomena to 10 for complete sky cover. The number of clear days is based on average cloudiness 0-3, partly cloudy days 4-7, and cloudy days 8-10 tenths.
- Solar radiation data are the averages of direct and diffuse radiation on a horizontal surface. The lagrange correction on data per square centimeter.

Figures in inches in a direction column indicate direction in terms of degrees from true North; N., 0°-East, 90°-South, 180°-West, 270°-North, and 00°-Calm. Readings of 1000 are assumed in the direction column unless "Fastest mile" the corresponding speeds are assumed observed 1-minute values.

AVERAGE TEMPERATURE

Table showing average temperature by month for years 1931 to 1970, with columns for Year, Jan, Feb, Mar, Apr, May, June, July, Aug, Sept, Oct, Nov, Dec, Annual. Includes record min and max values.

TOTAL DEGREE DAYS

Table showing total degree days by month for years 1931 to 1970, with columns for Season, July, Aug, Sept, Oct, Nov, Dec, Jan, Feb, Mar, Apr, May, June, Total. Includes record min and max values.

COLUMBIA, SOUTH CAROLINA

TOTAL PRECIPITATION

Table showing total precipitation by month for years 1931 to 1970, with columns for Year, Jan, Feb, Mar, Apr, May, June, July, Aug, Sept, Oct, Nov, Dec, Annual. Includes record min and max values.

TOTAL SNOWFALL

Table showing total snowfall by month for years 1931 to 1970, with columns for Season, July, Aug, Sept, Oct, Nov, Dec, Jan, Feb, Mar, Apr, May, June, Total. Includes record min and max values.

Record mean values above (not adjusted for instrument location changes listed in the Station Location table) are means for the period beginning in 1980.

Indicates a break in the data sequence during the year, or season, due to a station move or relocation of instruments. See Station Location table. Data are from City Office locations through 2-15-47 and from Airport locations thereafter.

STATION LOCATION

COLUMBIA, SOUTH CAROLINA

| Location | Occupied from | Occupied to | Airline distance and direction from previous location | Latitude North | Longitude West | Elevation above | | | | | | | | Remarks |
|--|---------------|-------------|---|----------------|----------------|-----------------|----------------------------|------------------|----------------------|--------------|------------------|--------------------------|---------------------|--|
| | | | | | | Sea level | Ground | | | | | | | |
| | | | | | | | Ground at temperature site | Wind instruments | Extreme thermometers | Psychrometer | Telepsychrometer | Tipping bucket rain gage | Weighting rain gage | |
| CITY OFFICE | | | | | | | | | | | | | | |
| Old Agricultural Hall near NW corner Gervais and Main Streets | 6- 8-87 | 6- 7-95 | | 34°00.0' | 81°02.5' | 310 | | 73 | | | | | 63 | Third order station U.S. Signal Service to 10-1-91, W.B. third order station after that. |
| Federal Building SW cor. Main & Laurel St. | 6- 8-95 | 2-15-01 | 2800 ft. NW | 34°00.4' | 81°02.5' | 322 | | 5 | | | | | 3 | |
| City Hall (former) NW corner Main and Gervais Streets | 3-15-01 | 10- 1-03 | 2800 ft. SSE | 34°00.0' | 81°02.5' | 310 | 122 | 114 | 114 | | 107 | | 107 | First order station. |
| Loan and Exchange Bank Building, SE corner Main and Washington Sts. | 10- 1-03 | 3- 1-05 | 800 ft. W | 34°00.2' | 81°02.5' | 320 | 175 | 167 | 167 | | 150 | | 150 | Exposures good except for rain gage which was too near a 6 foot parapet on roof. |
| Weather Bureau Building SE corner Laurel and Assembly | 3- 1-05 | 6- 3-35 | 2000 ft. NW | 34°00.4' | 81°02.5' | 340 | 57 | 41 | 41 | | 32 | | 32 | |
| Sylvan Building, NE cor. Main & Hampton Sts. | 6- 3-35 | 8-26-36 | 1350 ft. SE | 34°00.3' | 81°02.5' | 312 | 73 | 67 | 67 | | 58 | | | |
| U. S. Court House cor. (SE) Laurel and Assembly Streets | 8-26-36 | 6- 1-54 | 1350 ft. NW | 34°00.4' | 81°02.5' | 332 | 81 | 70 | 70 | | 68 | | | Triple register withdrawn 12-20-53. |
| AIRPORT STATION | | | | | | | | | | | | | | |
| Municipal Airport, Owens Field, 4 mi. SE of Columbia P.O. in Richland County | 3-11-34 | 3-24-38 | | 33°58.6' | 81°00.0' | 200 | 37 | 5 | 5 | | | | | 6-11-34 to 7-31-36. Observations by airline personnel; 8-1-36 to 10-31-39 obs. by WB airway obser. |
| Administration Building Municipal Airport Owens Field | 3-24-38 | 10-31-39 | 265 ft. NE | 33°58.6' | 81°00.0' | 202 | 42 | 27 | 27 | | | | 26 | Observations by WB airway observers. |
| Municipal Airport Owens Field | 11- 1-39 | 4-17-44 | No Change | 33°58.6' | 81°00.0' | 202 | 42 | 27 | 27 | | | | 26 | Airway and synoptic observations begun by CAA and from 3-28-42 daytime observations were made by WB airway observer. |
| Municipal Airport Owens Field | 4-17-44 | 2-14-47 | No Change | 33°58.6' | 81°00.0' | 202 | 42 | 27 | 27 | | | | 26 | WBAS with commissioned personnel activated. |
| Bldg. 317, Columbia Metropolitan AP (Columbia AP to Jan. 1965). | 2-14-47 | 1-12-67 | 5.8 mi. WSW | 33°56.7' | 81°07.0' | 217 | 36 | 6 | 5 | | a4 | | 4 | a - Added 12-20-53. |
| Vec. Bur./FAA Building Columbia Metropolitan Airport | 1-12-67 | Present | 2,000 ft. W | 33° 57' | 81° 07' | 213 | 20 | a5 | | | | 4 | 3 | a - Standby equipment. b - 2500 feet S of temperature sensor at previous location. |

Requests for additional information should be directed to the National Weather Service Office for which this summary was issued.

Sale Price: 15 cents per copy. Checks and money orders should be made payable to the Superintendent of Documents. Remittances and correspondence regarding this publication should be sent to the Superintendent of Documents, Government Printing Office, Washington, D. C. 20402

USCOPM-NOAA-ASHEVILLE - 750

U.S. DEPARTMENT OF COMMERCE
NATIONAL CLIMATIC CENTER
FEDERAL BUILDING
ASHEVILLE, N.C. 28801



310-Dec.
Atomic Power Dept-Westinghouse "BA"
ATT: W. Geiger, Nuclear Fuel Div.
Box # 5906, Bluff Road
Columbia, S. C. 29205

South Carolina Streamflow Characteristics

Low-Flow Frequency and Flow Duration



UNITED STATES
DEPARTMENT OF THE INTERIOR
GEOLOGICAL SURVEY

OPEN FILE REPORT

SATTEE RIVER BASIN

83

2-1695. Congaree River at Columbia, S. C.

Location.--Lat 33°59'35", long 81°03'00", on right bank at Columbia, Richland County, 1,000 ft downstream from Gervais Street Bridge and 1.4 miles downstream from confluence of Broad and Saluda Rivers.

Drainage area.--7,850 sq mi, approximately.

Records available.--October 1939 to September 1965.

Remarks.--Flow regulated since 1929 by Lake Murray (see station 2-1690.), and since 1940 by Lake Greenwood (see station 2-1670.), and to some extent at low and medium flows by powerplants on the Broad River. City of Columbia diverts about 25 cfs above station for municipal supply.

MAGNITUDE AND FREQUENCY OF ANNUAL LOW FLOWS

| Period (Consecutive days) | Lowest average flow, in cubic feet per second, for indicated recurrence interval, in years | | | | |
|------------------------------|---|-------|-------|-------|-------|
| | 2 | 5 | 10 | 20 | 40 |
| 7 | 3,350 | 2,140 | 1,590 | 1,210 | 920 |
| 30 | 4,160 | 2,810 | 2,200 | 1,770 | 1,410 |
| 60 | 4,950 | 3,470 | 2,770 | 2,210 | 1,840 |
| 120 | 5,750 | 4,050 | 3,200 | 2,580 | 2,080 |
| 274 | 7,150 | 5,200 | 4,220 | 3,510 | 2,950 |

DURATION OF DAILY FLOW

| Period | Flow, in cubic feet per second, which was equaled or exceeded for indicated percent of time | | | | | | | | | | | |
|---------|---|--------|-------|-------|-------|-------|-------|-------|-------|-------|-------|------|
| | 2 | 10 | 30 | 50 | 70 | 80 | 90 | 95 | 98 | 99 | 99.5 | 99.9 |
| 1940-65 | 37,000 | 15,700 | 9,200 | 6,850 | 5,180 | 4,280 | 3,220 | 2,500 | 1,820 | 1,500 | 1,260 | 800 |

LOWEST MEAN DISCHARGE, IN CUBIC FEET PER SECOND, FOR THE FOLLOWING NUMBER OF CONSECUTIVE DAYS IN YEAR BEGINNING APRIL 1

| Year | 1 | 3 | 7 | 14 | 30 | 60 | 90 | 120 | 150 | 183 | 274 |
|------|--------|--------|--------|--------|--------|--------|--------|---------|---------|---------|---------|
| 1940 | 850.0 | 1450.0 | 1770.0 | 1990.0 | 2650.0 | 2900.0 | 3150.0 | 3460.0 | 5440.0 | 5340.0 | 5760.0 |
| 1941 | 1040.0 | 2190.0 | 2920.0 | 3050.0 | 3520.0 | 3750.0 | 4440.0 | 5480.0 | 5570.0 | 5600.0 | 6620.0 |
| 1942 | 1910.0 | 2900.0 | 3650.0 | 3890.0 | 4260.0 | 4870.0 | 5220.0 | 5610.0 | 6010.0 | 6300.0 | 6620.0 |
| 1943 | 2150.0 | 2910.0 | 3420.0 | 4400.0 | 4450.0 | 4940.0 | 5040.0 | 5280.0 | 5690.0 | 6010.0 | 7400.0 |
| 1944 | 1430.0 | 2480.0 | 3560.0 | 3930.0 | 4510.0 | 5180.0 | 5420.0 | 5630.0 | 5550.0 | 5670.0 | 6340.0 |
| 1945 | 1810.0 | 2450.0 | 3190.0 | 3680.0 | 4000.0 | 4170.0 | 4990.0 | 5390.0 | 5640.0 | 7660.0 | 7890.0 |
| 1946 | 2350.0 | 3630.0 | 4190.0 | 5500.0 | 5870.0 | 6830.0 | 7000.0 | 7200.0 | 7390.0 | 7610.0 | 8350.0 |
| 1947 | 1840.0 | 2450.0 | 3230.0 | 4040.0 | 4410.0 | 5120.0 | 5270.0 | 5510.0 | 5470.0 | 5780.0 | 8000.0 |
| 1948 | 1840.0 | 2630.0 | 3000.0 | 4060.0 | 5110.0 | 5870.0 | 6790.0 | 7100.0 | 6940.0 | 7130.0 | 9950.0 |
| 1949 | 2860.0 | 4200.0 | 5090.0 | 5370.0 | 6410.0 | 7470.0 | 8200.0 | 8420.0 | 9220.0 | 10000.0 | 11100.0 |
| 1950 | 2380.0 | 2970.0 | 4580.0 | 5040.0 | 5290.0 | 5850.0 | 6120.0 | 6220.0 | 6510.0 | 6550.0 | 6700.0 |
| 1951 | 1480.0 | 1920.0 | 3050.0 | 3390.0 | 3600.0 | 4060.0 | 4410.0 | 4660.0 | 4730.0 | 4810.0 | 5630.0 |
| 1952 | 1300.0 | 2340.0 | 2990.0 | 4310.0 | 5320.0 | 5570.0 | 5660.0 | 5880.0 | 6260.0 | 6300.0 | 6760.0 |
| 1953 | 1380.0 | 2630.0 | 3520.0 | 3680.0 | 3850.0 | 4350.0 | 4670.0 | 4850.0 | 4810.0 | 4930.0 | 5750.0 |
| 1954 | 662.0 | 688.0 | 964.0 | 1250.0 | 1660.0 | 2140.0 | 2470.0 | 2680.0 | 2820.0 | 2910.0 | 3350.0 |
| 1955 | 890.0 | 1090.0 | 1310.0 | 1370.0 | 1760.0 | 2240.0 | 2220.0 | 2370.0 | 2480.0 | 2830.0 | 3710.0 |
| 1956 | 770.0 | 1290.0 | 1880.0 | 2080.0 | 2300.0 | 2500.0 | 2620.0 | 2680.0 | 3120.0 | 3130.0 | 3900.0 |
| 1957 | 1350.0 | 2110.0 | 2650.0 | 3070.0 | 3410.0 | 3950.0 | 4310.0 | 5090.0 | 5160.0 | 5740.0 | 8040.0 |
| 1958 | 1070.0 | 2040.0 | 2720.0 | 3380.0 | 3460.0 | 4280.0 | 4510.0 | 4580.0 | 4990.0 | 5660.0 | 6380.0 |
| 1959 | 2160.0 | 3130.0 | 3550.0 | 4200.0 | 5060.0 | 7740.0 | 7860.0 | 8040.0 | 8260.0 | 8650.0 | 10600.0 |
| 1960 | 2560.0 | 3900.0 | 4820.0 | 4980.0 | 5160.0 | 5720.0 | 5940.0 | 6430.0 | 6600.0 | 6730.0 | 7040.0 |
| 1961 | 2280.0 | 2820.0 | 3190.0 | 3390.0 | 4030.0 | 4700.0 | 5250.0 | 6200.0 | 6940.0 | 7720.0 | 9420.0 |
| 1962 | 2590.0 | 3040.0 | 3310.0 | 4000.0 | 4520.0 | 5160.0 | 5320.0 | 5560.0 | 5680.0 | 5870.0 | 6690.0 |
| 1963 | 1860.0 | 2600.0 | 2840.0 | 3210.0 | 4340.0 | 4800.0 | 4880.0 | 5100.0 | 5570.0 | 6020.0 | 6790.0 |
| 1964 | 3220.0 | 4070.0 | 5170.0 | 5600.0 | 6040.0 | 7220.0 | 8690.0 | 10000.0 | 10500.0 | 12900.0 | 13900.0 |

70-1086
70-1143

For Div. of ~~Engineering~~

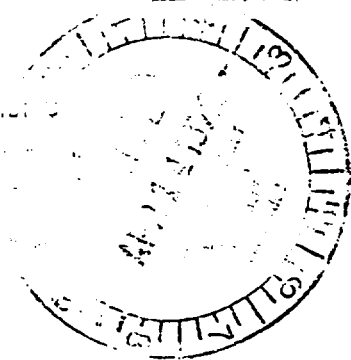

Rev 375
Pittsburgh Pennsylvania 15230
April 13, 1972

Westinghouse Electric Corporation

U. S. Atomic Energy Commission
Division of Materials Licensing
Washington, D. C. 20545

Attention: Mr. Donald A. Nussbaumer, Chief
Fuel Fabrication and Transportation Branch

Gentlemen:

Subject: Application for Amendment of License SNM-1120, Docket 70-1143, License SNM-338, Docket 70-337 and Termination of SNM-1170, Docket 70-1086

The Westinghouse Electric Corporation hereby requests that License SNM-1120, Docket 70-1143, be amended in accordance with our application, dated December 10, 1971, and the attachment to this letter.

The attachment to this letter is intended to be responsive to your letter, dated March 1, 1972. It revises the application originally transmitted on June 13, 1969, and the application originally transmitted on January 14, 1971. The revised pages should be filed as part of the appropriate document.

Also, Westinghouse would concur with the addition of a license condition as proposed in your letter, dated March 1, 1972 if it could be modified as indicated in the following version:

- 24. For the materials specified in Items 7.A, 7.B, 7.C and 7.D notwithstanding the requirements imposed by Paragraph 7.2, page 66 of the application dated June 13, 1969, fissile units not in fixed linear arrays shall be arranged in rectangular lattice patterns; and the area per unit, in the surface density calculation for adjacent units, shall be based on a square lattice having a center-to-center distance equal to the closer of the two actual values.

4/27/72
C/2490

(2)

ITEM # 390

~~SECRET~~

The changes proposed by Westinghouse have been underlined. The new number and references to Items 7.A through 7.D are editorial changes to adapt the proposed condition to the revised license format. The exclusion of units "in fixed linear arrays" is intended to recognize the facts that (1) the condition as originally proposed was apparently not intended to apply to SNM in linear arrangements; (2) under this license, the PFDL activities are conducted mostly within glove boxes, such that the SNM is maintained in linear arrays, within glove box lines; and (3) that determining spacings between fixed linear arrays is a straightforward matter of assuring that the exclusion areas determined for one line do not overlap the spacings determined for any other line. The insertion of the restriction to "adjacent units" again is a practical consideration in that the spacing available around a unit should be determined relative to nearby units and not to remote units that would actually have negligible effects on the exclusion area available to the unit of interest.

The Westinghouse Electric Corporation iterates its request that, concurrent with the issuance of an amended License SNM-1120 in accordance with the above request, the USAEC terminate License SNM-1170, Docket 70-1086, and delete authorization to possess and use licensed materials in Building 7 from License SNM-338, Docket 70-337.

Please send the amended licenses to me at the above address.

If you have any questions, please write to me at the above address or telephone me collect, (412) 373-4652.

Very truly yours,



Karl R. Schendel
License Administrator

KRS:jh

7 copies transmitted

Vestinghouse Electric Corporation

Power Systems



PWR Systems Division

Box 355
Pittsburgh Pennsylvania 15230

July 26, 1971

Handwritten signatures and initials:
C. [unclear]
W. [unclear]
S. [unclear]

Handwritten initials: HP

U.S. Atomic Energy Commission
Division of Materials Licensing
Washington, D. C. 20545

Attention: Mr. Charles Macdonald
Fuel Fabrication and Transportation Branch

Stamp: U.S. Atomic Energy Commission

Gentlemen:

Subject: Application for Amendment of License SNM-338
Docket 70-337, to Authorize Use of NFD Shipping
Packages

The attached copies of Military Standard MS 24347 were inadvertently omitted from our transmittal, dated July 23, 1971, on the above subject.

Thank you for undertaking to insert them properly into the transmittal.

If you have any questions, please write to me at the above address or telephone me collect (412) 373-4652.

Very truly yours,

Handwritten signature: Karl R. Schendel

Karl R. Schendel
License Administrator

KRS:jh

Attachment

Handwritten: 272
C/371

ITEM # 391 3402

Westinghouse Electric Corporation

Power Systems



DOCKET NO.

70-337

WPK
11/15/71

Nuclear Fuel Division
Manufacturing Department

For Div. of Compliance

Box 5900
Columbia South Carolina 29205
803 776-2610

Hyp

December 10, 1970

U. S. Atomic Energy Commission
Division of Materials Licensing
Washington, D.C. 20545

Attention: Mr. Donald A. Nussbaumer, Chief
Source and Special Nuclear Materials Branch

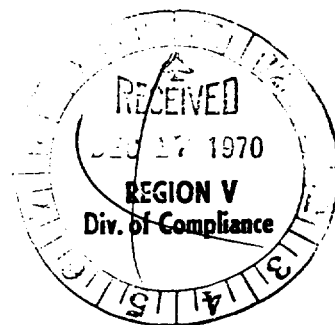

Gentlemen:

Subject: Application for Amendment of License SNM-338,
Docket 70-337, to Authorize Use of NFD Shipping
Packages

The Westinghouse Electric Corporation hereby transmits drawing C883D214 as requested in your telephone call of December 8, 1970.

If you have any questions, please telephone me collect, (412) 255-3907.

Very truly yours,

Karl R Schendel

Karl R. Schendel
License Administrator

KRS:kh

Attachment: Drawing C883D214
7 copies transmitted

DEC 17 1970
REGION V
Div. of Compliance

273
CL

U

ITEM # 392

3504

Westinghouse Electric Corporation

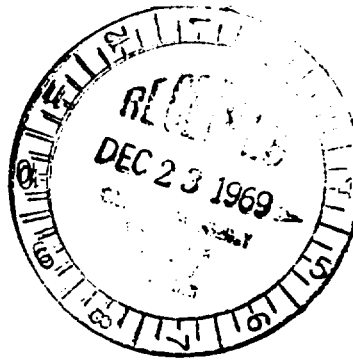

Gateway Center
Box 2278
Pittsburgh Pennsylvania 15230

Handwritten notes:
~~6/10/69~~
6/10/69
12/30

December 22, 1969

Handwritten initials: HJ

U. S. Atomic Energy Commission
Division of Materials Licensing
Washington, D. C. 20545

Attention: Mr. Donald A. Nussbaumer, Chief
Source and Special Nuclear Materials Branch

Subject: Application for an Amendment to License SNM-338,
For Div. of Compliance Docket 70-337, to Authorize the Use of an AML
Shipping Package

Gentlemen:

With reference to your letter of December 4, 1969, concerning our application to increase the authorized loading of a Model III-B-2-W package, we would be happy to supply the requested information if it is of academic interest to you. However, we have determined that a specification packaging offers a desirable degree of flexibility. Therefore, Westinghouse withdraws the subject application, dated October 20, 1969, and no longer requests any action on the part of the Commission.

If you have any questions, please write to me at the above address or telephone collect (412) 255-3907.

Very truly yours,

Handwritten signature: Karl R. Schendel

Karl R. Schendel
License Administrator

KRS:sw

7 copies transmitted

Handwritten: 274
C/12/1969

ITEM # 393

Handwritten: H

3343

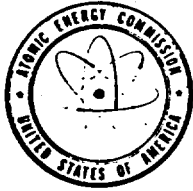

UNITED STATES
ATOMIC ENERGY COMMISSION
WASHINGTON, D.C. 20545

DEC 4 1969

DML:CEM
70-337

SNM 338

~~12/9/69~~
12/9/69

H80

Westinghouse Electric Corporation
Gateway Center
Box 2278
Pittsburgh, Pennsylvania 15230

Attention: Mr. Karl R. Schendel
License Administrator

Gentlemen:

This refers to your application dated October 20, 1969, requesting an increase in the fissile content loading and an increase in the number of packages per shipment for the Model III-B-2-W package licensed by Amendment No. 71-29 to Special Nuclear Material License No. SNM-338.

In connection with our review of this application, we need information regarding:

1. The conditions assumed in the nuclear safety analysis, and
2. Establishment of the adequacy and applicability of the calculational method.

Sincerely,

Original Signed by
Donald A. Nussbaumer

Donald A. Nussbaumer, Chief
Source & Special Nuclear
Materials Branch
Division of Materials Licensing

DISTRIBUTION:

Docket File
Document Room
Compliance, HQ (2)
C. D. Luke, CB:DML
N. Doulos, DML
Branch Reading File
Division Reading File

ITEM # 394

C/BNV
275



Handwritten notes and date: 10/20/69

Westinghouse Electric Corporation

Gateway Center
Box 2278
Pittsburgh Pennsylvania 15230

October 20, 1969

HSP

U. S. Atomic Energy Commission
Division of Materials Licensing
Washington, D. C. 20545

Attention: Mr. Donald A. Nussbaumer, Chief
Source and Special Nuclear Materials Branch

Subject: Amendment to License SNM-338, Docket 70-337,
to Authorize the Use of an AML Shipping Package

For Div. of Compliance

Gentlemen:

The Westinghouse Electric Corporation hereby requests an amendment to License SNM-338, Docket 70-337, authorizing the delivery of special nuclear material to a carrier for transport in the packaging described herein.

The packaging will be a NUMEC Model III-B-2 shipping container. This packaging has been reviewed by the USAEC and its use was authorized by Amendment 71-29 to License SNM-338, Docket 70-337.

Specifically, we request that a superseding amendment be issued which differs from Amendment 71-29 in the following particulars:

- Item 5 (b) (1) - "Plutonium-uranium carbide or plutonium-uranium oxide, with a maximum 25 w/o plutonium....." (No other changes.)
- Item 5 (b) (2) - "Combined contents not to exceed 80 kg with the ²³⁵U content not to exceed 800 grams and the plutonium content not to exceed 250 grams."
- Item 5 (c) (1) "Two (2)"

Handwritten notes: C/276, 370, and a circled 2

ITEM # 395 3313

October 20, 1969

Computations to determine the reactivity of the III-B-2 packaging when loaded as described, which were carried out by Westinghouse using the IDX code (R. W. Hardie and W. W. Little, BNWL-954) resulted in maximum values for k_{eff} of < 0.7 for a single package; < 0.9 for two packages in the damaged condition; and < 0.95 for four undamaged packages in a single shipment. Therefore, a Fissile Class III shipment of two (2) packages meets the nuclear criticality safety requirements of 10CFR71.40.

Please send the amendment to me at the above address.

If you have any questions, please write to me at the above address or telephone me collect, (412) 255-3907.

Very truly yours,



Karl R. Schendel
License Administrator

KRS:sw

7 copies transmitted

008

~~70-21-68~~
300 PM

//RB
DO U READ ME

//RB

SNM 338
DOCKET NO. 70-337

MS#

TWX NR 857

For Div. of Compliance

USAEC HQS GTWN

Craker
WAC
10/28

WESTINGHOUSE PGH
CHARLES McDONALD
U.S. ATOMIC ENERGY COMMISSION
DIVISION OF MATERIALS LICENSING
SOURCE AND SPECIAL NUCLEAR MATERIALS BRANCH
WASHINGTON DC
10-21-68 122PM

HO

THE FOLLOWING INFORMATION SUPPLEMENTS OUR APPLICATION, DATED JULY 19, 1968, FOR AMENDMENT OF LICENSE SNM-338, DOCKET 70-337, REQUESTING AUTHORIZATION TO FABRICATE AND PACKAGE SAXTON 9X9 FUEL ASSEMBLIES.

1. THE ASSEMBLIES WILL BE PLACED IN THE METAL BOXES USED FOR SHIPPING SELNI FUEL RODS. THE BOXES WILL BE RETAINED IN THE CC PACKAGINGS IN THE SAME MANNER AS THE SELNI FUEL RODS. THIS PACKING TECHNIQUE WAS APPROVED BY AMENDMENT 71-10, DATED JANUARY 3, 1968, TO LICENSE SNM-338.
2. SPECIFIC PARAMETERS CONCERNING THE SAXTON PACKAGE CONTENTS ARE --

| | |
|-----------------------|----------------|
| FUEL MATERIAL | UO2 |
| ENRICHMENT /MAX/ | 12.7 W/O |
| PELLET DIAMETER /NOM/ | 0.337" |
| CLADDING MTL | ZIRC. 4 OR SST |
| ROD DIAMETER /NOM/ | 0.391" |
| FUEL LENGTH /NOM/ | 36" |
| RODS PER ASSY /MAX/ | 72 |
| MAX 235U PER ASSY | 3.5 KG |
| MAX 235U PER PACKAGE | 14.0 KG |

IF YOU HAVE ANY FURTHER QUESTIONS, PLEASE TELEPHONE ME COLLECT AT /412/ 256-3907.

KARL R. SCHENDEL LICENSE ADMINISTRATOR WESTINGHOUSE ELEC CORP
GATEWAY CENTER PITTSBURGH PA

C/2076
277

IF THIS WIRE D

ITEM # 396

OCT 24 1968



Westinghouse Electric Corporation

3 Gateway Center
Box 2178, Pittsburgh, Pa. 15230

July 26, 1968

For Div. of Compliance

Handwritten signature/initials

U. S. Atomic Energy Commission
Division of Materials Licensing
Washington, D. C. 20545

Attention: Mr. Donald A. Nussbaumer, Chief
Source and Special Nuclear Materials Branch

HP

Subject: Application for an Amendment to License SNM-338,
Docket 70-337, to Authorize Processing of 30 w/o
Enriched Uranium in the NFD Manufacturing Department

For Div. of Compliance

Gentlemen:

The Westinghouse Electric Corporation hereby requests an amendment to License SNM-338, Docket 70-337. The amendment would authorize the Manufacturing Department of the Nuclear Fuel Division to process uranium enriched up to 30 w/o in the isotope ^{235}U in accordance with the attachment to this letter.

Please send the amendment to me at the above address.

If you have any questions, please write to me at the above address or telephone me collect, (412) 255-3907.

Very truly yours,

Karl R. Schendel

Karl R. Schendel
License Administrator

Attachment

7 copies transmitted

ITEM # 397

AUG 2 1968

Handwritten initials and marks

2686

SNM-338
30 w/o Inspect.
7/26/68

WESTINGHOUSE ELECTRIC CORPORATION
3 Gateway Center, Box 2278
Pittsburgh, Pennsylvania 15230

The Manufacturing Department of the Nuclear Fuel Division (NFD) requests approval to process uranium oxide enriched ≤ 30 w/o in the isotope ^{235}U in the form of jacketed fuel rods. The pelleting, jacketing and other fabrication operations will be performed by another facility.

Jacketed fuel rods, clearly identified, will be moved directly to or from the fuel rod storage area. The processing, which will be x-ray inspection, helium leak testing or similar non-destructive testing, will use the controls listed below.

Maximum Permissible Values

| | |
|----------------|--|
| Mass | 2.7 pounds UO_2 |
| Slab Thickness | 0.8 inches |
| Spacing | 175 grams $^{235}\text{U}/\text{ft}^2$; OR spacing sufficient to assure an average "smeared" slab thickness of 0.47." Not withstanding these limits, 30 w/o material will be separated from any other material by at least 12 inches. |

The mass limit is the 350 g ^{235}U limit given in Table I of TID-7016, converted into pounds of UO_2 .

The slab thickness is 0.84 times the minimum critical thickness of an infinite slab of heterogeneous, fully enriched uranium dioxide at approximately 96% of theoretical density. This thickness was computed using LEOPARD^{/1} procedures, assuming optimum light water moderation and full reflection.

The 175 g ²³⁵U/ft² value is derived using the surface density method and is applicable to solutions of fully enriched uranium. The 0.47 in. "smeared" thickness limit is 50% of the computed minimum critical thickness of an infinite slab which is discussed above.

The processing of this material will present no radiation protection hazards which are significantly different from those associated with the lower enriched SNM which is normally processed in the Manufacturing Department.

^{/1} Barry, R.F., "LEOPARD - A Spectrum Dependent Non-Spatial Depletion Code for the IBM 7094," WCAP-3269-26
(September 1963)

DOCKET NO. 70-337
Ext Div of Compliance



Croft
WRT 11/11

Westinghouse Electric Corporation

Gateway Center
Box 2278
Pittsburgh Pennsylvania 15230

November 12, 1969

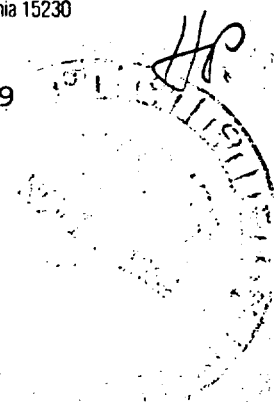

U. S. Atomic Energy Commission
Division of Materials Licensing
Washington, D. C. 20545

Attention: Mr. Donald A. Nussbaumer, Chief
Source and Special Nuclear Materials Branch

Gentlemen:

Subject: Application, dated September 11, 1968, for an
Amendment to License SNM-338, Docket 70-337

With reference to your letter of September 17, 1969, regarding the subject application, the Westinghouse Electric Corporation concurs with your intent to vacate the application. As discussed with your Mr. R. E. Layfield, we intend to submit in the near future an application which is to be independent of and completely supersede the subject application. We assume that vacating the subject application for amendment will have no effect on the existing license.

On the same subject, with reference to your letter of January 20, 1969, as a formality, we withdraw our request that the attached paper by Mr. T. Gutman be withheld from public disclosure.

If you have any questions, please write to me at the above address or telephone me collect, (412) 255-3907.

Very truly yours,

Karl R. Schendel

Karl R. Schendel
License Administrator

KRS:sw

ITEM # 398

C/2778
279 3579

COMPLIANCE - I

*applic
8/22/66*

RECEIVED

1966 SEP 6 PM 1 56

U. S. ATOMIC ENERGY COMM.
REGULATORY
MAIL SECTION

TWX NO 490

MR. DONALD A. NUSSBAUMER, CHIEF
SOURCE AND SPECIAL NUCLEAR MATERIALS BRANCH
U. S. ATOMIC ENERGY COMMISSION
WASHINGTON, D. C.
9-6-66 1002AM

THE FOLLOWING INFORMATION SUPPLEMENTS AND REVISES OUR APPLICATION
DATED 8/22/66 FOR AMENDMENT OF LICENSE SNM-338 DOCKET 70-337 --

1. ADMINISTRATIVE CONTROL OF THE PACKAGING OPERATION WILL BE IN ACCORDANCE WITH THE REQUIREMENTS OF THE WESTINGHOUSE ELECTRIC CORPORATION HEALTH PHYSICS MANUAL, WAFD-HP-103, REVISION V, PARTICULARLY SECTION 12.1. THIS MANUAL WAS TRANSMITTED ON DOCKET 70-337 ON 7/28/66.
2. SPECIAL NUCLEAR MATERIALS IN THE FORM OF CHIPS, POWDERS OR SOLUTIONS WILL NOT BE OFFERED FOR TRANSPORT UNDER THE AUTHORIZATION REQUESTED IN THIS APPLICATION.
3. THE CLOSURE AS SPECIFIED IN REFERENCE APPLICATION NUMBER 1 IS A STANDARD THREADED PIPE CAP WHICH WILL ENGAGE A MINIMUM OF FIVE FULL THREADS WHEN TIGHTENED.
4. ALL REFERENCES TO THE USE OF THIS PACKAGE FOR A CLASS III SHIPMENT ARE HEREBY DELETED. THE PACKAGES WILL BE USED ONLY FOR CLASS II SHIPMENTS AS DESCRIBED IN OUR 8/22/66 TRANSMITTAL.

KARL R. SCHENDEL LICENSE ADMINISTRATOR WESTINGHOUSE ELEC CORP
GATEWAY CENTER PITTSBURGH PA

③

2542

ITEM # 399

From CO - Hdqrs.

*CDM
8/30*

TWX NR 468

8/22/66 1.45 PM

MR. D. A. NUSSBAUMER' CHIEF
SOURCE AND SPECIAL NUCLEAR MATERIALS BRANCH'
WASHINGTON. D. C.

For Div of Compliance

AN AMENDMENT TO LICENSE SNM-338' DOCKET 70-337' IS HEREBY
REQUESTED TO AUTHORIZE THE DELIVERY OF THE SHIPPING PACKAGE
DESCRIBED HEREIN TO A CARRIER FOR TRANSPORT.

PACKAGE DESCRIPTION -

GROSS WEIGHT - 470 POUNDS

MODEL - SPERT FUEL ROAD SHIPPING CONTAINER' S.E. NO. 1826

FABRICATION - SEE REFERENCE APPLICATION NO. 1

COOLANTS - NOT APPLICABLE

ACTIVITY - NOT APPLICABLE

SNM - URANIUM AT ANY ENRICHMENT UP TO FULLY ENRICHED IN THE
ISOTOPE U-235.

FORM - CLAD FUEL ELEMENTS AND FUEL ASSEMBLIES.

NEUTRON ABSORBERS - NOT APPLICABLE

MAX. WEIGHT OF FUEL - 2 KILOGRAMS MAX. TOTAL U-235.

MAX. WEIGHT OF CONTENTS - 120 POUNDS

MAX. DECAY HEAT - NOT APPLICABLE

SUBPART C STDS -

GENERAL - SEE REFERENCE APPLICATION NO. 1

CRITICALITY - SEE REFERENCE APPLICATION NO. 2. THE AVERAGE
FUEL DENSITY WILL BE LESS THAN ONE GRAM U-235 PER CC.

THIS DENSITY IS TYPICAL OF SOLUTIONS. TABLE I OF TID-7016'
REV. 1 SHOWS THAT A 5 INCH DIAMETER IS NUCLEARLY SAFE FOR
ALL DEGREES OF MODERATION AND REFLECTION.

CRITICALITY' LIQUIDS - NOT APPLICABLE.

NORMAL CONDITIONS - RADIOACTIVITY - NOT APPLICABLE.

NORMAL CONDITIONS - CRITICALITY

SEE REFERENCE APPLICATION NO. 1. NORMAL CONDITIONS WILL NOT
EFFECT THE CRITICALITY OR GEOMETRY OF THE PACKAGING.

OPTIMUM MODERATION HAS BEEN ASSUMED IN THE NUCLEAR SAFETY
ANALYSIS.

ACCIDENT CONDITIONS - CRITICALITY

SEE REFERENCE APPLICATION NO. 1. THE FREE DROP WILL NOT
APPRECIABLY EFFECT THE GEOMETRY. THE LIMITATION OF THE
CONTENTS TO SOLID CLAD FUEL WILL OBLVIATE THE EFFECTS OF THE
THERMAL CONDITIONS. THE ASSUMPTION OF OPTIMUM MODERATION AND
FULL REFLECTION WILL OBLVIATE THE PUNCTURE AND WATER IMMERSION
CONDITIONS.

EVALUATION OF ARRAY - SOLID MANGLE CALCULATIONS FOR AN ARRAY OF
PACKAGES 3 WIDE AND 2 HIGH' ASSUMING THE INNER RECEPTABLES TO
BE CONTINUOUS INFINITE CYLINDERS' SHOW THAT THE TOTAL
RESULTING SOLID ANGLE IS LESS THAN THE 3.2 STERADIANS SHOWN
AS THE ALLOWABLE SOLID INTERACTION ANGLE FOR A 5 INCH
DIAMETER INFINITE CYLINDER IN TABLE XVII' PAGE 29' K-1019'
REV. 5. THESE CALCULATIONS ASSUME OPTIMUM MODERATION AND FULL
REFLECTION OF THE FUEL IN THE 5 INCH CYLINDERS' BUT NO CREDIT
WAS TAKEN FOR THE PARASITIC NEUTRON ABSORPTION OF THE
INTERVENING PACKAGING STRUCTURES.

FISSILE CLASS III SHIPMENTS - A MAXIMUM OF 36 PACKAGES WILL BE SHIPPED IN AN ARRAY 3 WIDE X 2 HIGH X 6 PACKAGES LONG. AS SHOWN A 2 X 3 ARRAY IS NUCLEARLY SAFE FOR ANY LENGTH. THE SHIPMENT WILL BE MADE USING EXCLUSIVE USE OF THE VEHICLE OR ACCOMPANIED BY AN ESCORT AS SPECIFIED IN ICC REGULATIONS.

FISSILE CLASS II SHIPMENTS - AS SHOWN ABOVE 36 PACKAGES CONSTITUTE A NUCLEARLY SAFE SHIPMENT. ONE-FIFTH OF 36 IS 7 COMPLETE PACKAGES. 40 DIVIDED BY 7 IS 5.71 OR 5.8 RADIATION UNITS. WITH THIS NUMBER OF RADIATION UNITS A MAXIMUM OF 6 PACKAGES CAN BE SHIPPED AS A FISSILE II SHIPMENT.

PRELIMINARY DETERMINATIONS - NOT APPLICABLE.

ROUTINE DETERMINATIONS - THE PACKAGING WILL BE EXAMINED VISUALLY PRIOR TO EACH USE TO ASSURE THAT IT HAS NOT BEEN SIGNIFICANTLY DAMAGED.

REFERENCE APPLICATION NO. 1 - APPLICATION FOR AMENDMENT OF SNM-338 DOCKET 70-337 DATED MAY 25 1964 AS SUPPLEMENTED JUNE 11 1964 AND APPROVED JUNE 18 1964.

REFERENCE APPLICATION NO. 2 - APPLICATION FOR AMENDMENT OF SNM-338 DOCKET 70-337 DATED DECEMBER 29 1964 AS SUPPLEMENTED JANUARY 6 1965 AND APPROVED JANUARY 26 1965.

REVIEW AND APPROVAL OF THIS APPLICATION IS REQUESTED BY 8/26/66. IF THERE ARE ANY QUESTIONS PLEASE TELEPHONE ME COLLECT AT 412-391-2800 EXTENSION 3449.

KARL R. SCHENDEL LICENSE ADMINISTRATOR
WESTINGHOUSE ELECTRIC CORP. 3 GATEWAY CENTER PITTSBURGH PA

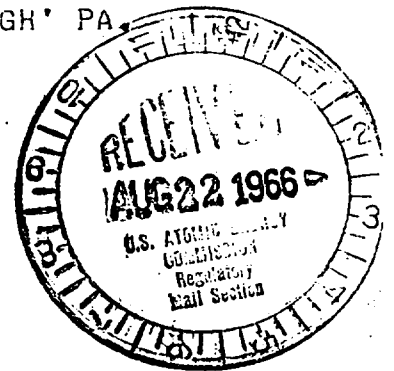

:9443:589, UNDER PARAGRAPH
CORRECTION UNDER PARAGRAPH

EVALUATION OF ARRAY - SOLID ANGLE CALCULATIONS
/NOT KAXXXX /NOT MANGLE
NOW READ SOLID ANGLE CALCULATION FOR AN ARRAY OF PACKAGES
3 WIDE AND 2 HIGH REPEAT ANGLE

PLS CORRECT

2413

S 1 TX END//RB#

I

DML:JLL
70-137

Westinghouse Electric Corporation
3 Gateway Center
Box 2878
Pittsburgh, Pennsylvania 15230

Attention: Mr. Karl R. Schendel
License Administrator

Gentlemen:

Pursuant to Title 10, Code of Federal Regulations, Part 71, the Westinghouse Electric Corporation is hereby authorized, under Special Nuclear Material License No. SNM-138, to use the ISO Shipping Package for transport of fuel assemblies for the Southern California Edison and Connecticut Yankee (proposed) reactors in accordance with the statements, representations and conditions specified in the application dated January 10, 1966.

All other conditions of this license shall remain the same.

Please note that this authorization covers shipment of fuel assemblies for the Southern California Edison or Connecticut Yankee reactors only. Use of this container for shipment of fuel assemblies, other than those previously approved under this license, must be specifically authorized prior to such use.

DISTRIBUTION:

Document No.
State Health
Compliance Hqrs. (2)
Suppl.
R. J. McAliff, CROO
B. George, BSM
N. Douglas, DML
C. Luke, DML:CB
C. Beck, DML:IFB
Pr. Reading File
Div. Reading File

FOR THE ATOMIC ENERGY COMMISSION

Donald A. Buschauer, Chief
Source & Special Nuclear Materials Branch
Division of Materials Licensing

Handwritten initials and date:
d/4/68
2/8/68

ITEM # 400

Form CO - FDns.

17

MAY 3 1965

C O L L E C T
X

USABC, GERMANTOWN, MARYLAND
DONALD A. NUSSBAUMER, CHIEF
SOURCE & SPECIAL NUCLEAR MATERIALS BRANCH
DIVISION OF MATERIALS LICENSING

WESTINGHOUSE ELECTRIC CORPORATION
3 GATEWAY CENTER
BOX 2278
PITTSBURGH, PENNSYLVANIA 15230

ATTENTION: MR. C. P. SKILLERN
LICENSE ADMINISTRATOR

PURSUANT TO THE TELEPHONE CONVERSATION ON APRIL 29, 1965 BETWEEN
YOUR MR. C. P. SKILLERN AND MYSELF, SPECIAL NUCLEAR MATERIAL LICENSE
NO. ~~5104-338~~ IS HEREBY AMENDED TO AUTHORIZE WEC TO POSSESS A MAXIMUM
OF 150 GRAMS OF U-235 IN THE METALLOGRAPHIC LABORATORY FOR PROCESSING
IN ACCORDANCE WITH THE PROCEDURES DESCRIBED IN SECTION 12.1 OF THE
APPLICATION DATED JANUARY 29, 1965, ~~FOR MANUFACTURE OF NAVAL REACTOR~~
CORES.

ALL OTHER CONDITIONS OF THIS LICENSE SHALL REMAIN THE SAME.

REFERENCE DML:RLL:70-337

DISTRIBUTION:

Doc. Room
Compliance (2) Headquarters
Suppl.
State Health
H. J. McAlduff, OROO
D. George, NMM
N. Doulos, ML
D. Nussbaumer, ML
Br. & Div. RPs

From CO - Hdqrs.

WPS
Hetson
O'Rilly
WMB
sd

APR 22 1965

DML:SKL
70-137

Applied
4/14/65

Westinghouse Electric Corporation
3 Gateway Center
Box 2178
Pittsburgh, Pennsylvania 15230

Attention: Mr. C. F. Skillern
License Administrator

Gentlemen:

Pursuant to 10 CFR 70, Special Nuclear Material License No. NMM-338
is hereby amended to authorize the use of shock-mounted containers
for shipment of Sixten (3 X 3) fuel assemblies in accordance with
the procedures described in the application dated April 14, 1965.

FOR THE U. S. ATOMIC ENERGY COMMISSION

Donald A. Nussbaumer, Chief
Source & Special Nuclear Materials Branch
Division of Materials Licensing

DISTRIBUTION:
Document Room
Div. of Compliance, Hq. (2)
H. J. McAlduff, OROO
D. George, NMM
N. Doulos, DML
State Health
Br. & Div. Reading files

DML DML:CB DML
Layfield/mad D.A.Nussbaumer
4-21-65



UNITED STATES
ATOMIC ENERGY COMMISSION
WASHINGTON, D.C. 20545

IN REPLY REFER TO:

DNL:ND
50-3
70-337

FEB 14 1967

DISTRIBUTION:
Document Room
Subject File
Branch Reading File
Division Reading File
J. Verme, NMM
N. Doulos, DML
Compliance, Region I
H. J. McAlduff, OROO
L. Johnson, DML

Westinghouse Electric Corporation
Atomic Power Division
Forest Hills Site
Box 355
Pittsburgh, Pennsylvania 15230

Attention: Mr. H. C. Amsberg, Manager
Operations Services

Gentlemen:

As requested in your letter dated February 1, 1967, distribution of 365 kilograms of contained U-235, 4.2% enriched as U F₆ is hereby authorized under License No. SNM-338. This distribution will be charged to the allocation issued to Consolidated Edison of New York, Inc., under their License No. DPR-5. Arrangements for procurement of the material should be made through the AEC Materials Leasing Officer, Oak Ridge, Tennessee.

Very truly yours,

Donald A. Nussbaumer, Chief
Source & Special Nuclear Materials Branch
Division of Materials Licensing

cc: Consolidated Edison Company of New York, Inc.
4 Irving Place
New York City, New York 10003

Attention: Mr. W. C. Beattie
Vice President

NOTE TO MR. McALDUFF, OROO

As you will note from the attached letter from Westinghouse, withdrawal is not desired until after July 1, 1967. Since the Commission has not yet approved FY 1968 allotments, we are unable at this time to issue the usual Nuclear Material Draft. We anticipate that you will be sent a draft covering these SNM requirements in late May or early June.

DAN

PH:RL
70-337 - 5NM-338
70-997

1966

Westinghouse Electric Corporation
3 Gateway Center
Box 2778
Pittsburgh, Pennsylvania 15220

Attention: Mr. Karl R. Schmedel
License Administrator

Gentlemen:

This confirms the telephone conversation on October 27, 1966, between your Mr. Karl R. Schmedel and Mr. R. L. Layfield of this office. As discussed, representatives of this Division would like to visit your facilities in the near future. The purpose of this visit would be to tour the Chaswick and Large, Pennsylvania sites and to discuss your applications dated June 8, July 8, and September 7, 1966, concerning the Astronuclear Laboratory and reprocessing of enriched uranium-bearing materials.

In addition to the specific items listed below, we would like to discuss certain aspects of these license applications concerning the proposed administrative controls and procedures. These would include such items as responsibilities and functions of safety organizations, communication between management and operational organizations, compliance and enforcement policies, audits, minimum specifications for radiological instrumentation and safeguards equipment, and radiological safety reviews. Furthermore, in view of the fact that both the uranium recovery and the plutonium operations covered by your applications dated September 16, and October 26, 1966, are to be performed at the Chaswick site and that the responsibility for safety of these operations as well as other activities covered under license No. 394-338 lies with the same organization, we would like to discuss the possibility of your submitting a comprehensive application covering the entire Chaswick site. Submission of such an application at this time would be appropriate since you are presently preparing your application for renewal of license No. 394-338.

DEC 27 1966

The following specific information regarding the Astronuclear Laboratory is requested:

1. There appears to be some misunderstanding regarding Item 5 in the attachment to our letter dated May 13, 1966. Based on the information discussed during the meeting on April 6, 1966, referenced in your application, it was our understanding that you would expand the demonstrative portion (Section 10) of this application providing definitive information including equipment layouts, storage arrays, monitor alarm placement, etc., and the appropriate nuclear and radiological safety analyses for each area to be covered by this license. It was agreed that such information, other than identification, would not be necessary for those areas where nuclear and radiological considerations were not significant (i.e., areas where less than 500 grams U-235 would be possessed). Accordingly, it is requested that you provide the appropriate information requested in Item 5 in the attachment to our letter dated May 13, 1966.
2. In Subparagraph 5.4.5, Health Physicist/Nuclear Safety Engineer, you have stated that a person holding this position would have a minimum of a Bachelor's Degree in one of the Sciences or Engineering, or equivalent. Please explain what you consider to be equivalent to a Bachelor's Degree and specify the minimum training and experience that would be required for this position. Also, since individuals working under the Health Physicist/Nuclear Safety Engineer have the responsibility for safety audits of operations, please specify the minimum training and experience required of these individuals.
3. The leak test requirements for sealed sources described in Section 11, pages 56 & 57, should be augmented to require the appropriate leak test in the absence of a certificate from a transferor indicating that a test has been made within the past six (6) months prior to the transfer. Also, the procedure should be changed to require that a report concerning the detection of alpha contamination in excess of 0.005 microcurie would be filed with the Director, Division of State and Licensee Relations, instead of the Director, Division of Materials Licensing.

DEC 27 1966

4. In the organizational chart on page 14 and the organizational information on page 15, it is not clear to whom the Manager, Industrial Hygiene reports. Also, the organizational chart does not reflect the health physics responsibilities under the Manager, Industrial Hygiene as specified on page 15.
5. Subparagraph 6.3.1 should be amended to include provisions for emergency equipment such as monitoring instruments, protective clothing and equipment, plant layouts, etc.

Very truly yours,

Donald A. Hassbauer, Chief
Source & Special Nuclear Materials
Branch
Division of Materials Licensing

DISTRIBUTION:
Doc. Rm. (2)
Branch & Division rfs
Compliance (2) HQrs
Suppl.
C. Luke, DML (2)
R. Layfield, DML

197

[The page contains several paragraphs of extremely faint, illegible text, likely bleed-through from the reverse side of the document. The text is scattered across the page and is mostly unreadable due to low contrast and noise.]

SCHEDULE

| <u>Material and Form</u> | <u>Enrichment U-235</u> |
|--------------------------|-------------------------|
| 5 kg U as UF6 | 13.5 w/o |
| 5 kg U as UF6 | 16.0 w/o |
| 5 kg U as UF6 | 17.0 w/o |
| 20 kg U as UF6 | 18.7 w/o |
| 6.5 kg U as UF6 | 20.0 w/o |

UF6 will be picked up by NFS, Inc., Erwin, Tennessee, as soon as it is available at the Commission's facility.

ITEM # 401



FOR Div of Compliance
WESTINGHOUSE ELECTRIC CORPORATION

Atomic Power Division

Box 355, Pittsburgh 30, Pa.

File

September 4, 1964

U. S. Atomic Energy Commission
Division of Materials Licensing
S. Elmo and Norfolk Avenues
Bethesda, Maryland

Attn: Mr. Lyall Johnson, Acting Director

cc: Mr. H. J. McAlduff, Leasing Officer
Production Division
U.S. Atomic Energy Commission
Oak Ridge, Tennessee

U. S. ATOMIC ENERGY COMM.
REGULATORY
MAIL SECTION

1964 SEP 8 PM 12 04

RECEIVED

Subject: Request for Special Nuclear Material Allocation

The Westinghouse Electric Corporation, Atomic Power Division, requests a fuel allocation for 30 kg of plutonium in the form of Pu metal or Pu oxide or both, all being required for the performance of the work covered by Contract AT(30-1)-3385. The required Pu is now in the possession of the Production Division, Hanford Operations Office and has been reserved for the work program described in the above named contract. The contract states that the Pu will be made available to the contractor (Westinghouse) "under Commission license and appropriate lease arrangements" and the Commission may in its discretion, waive any of its use charges and/or charges for losses and/or other charges under said lease agreements."

Licenses SNM-783 (Docket 70-826) and CX-6 (Docket 50-34) are in the process of being amended to authorize the partial performance of the work program described in the contract. An application for amendment to License No. SNM-338, (Docket 70-337) and SNM-770, (Docket 70-698) will be submitted in the future for the remaining work required under the contract on those licenses. All of the SNM licenses named above are associated with SNM Lease Agreement No. 245.

An appendix listing the tentative schedule is attached.

H. C. Amsberg, Manager
Administrative Services

Attachment

From CO - Hdqrs.

APPENDIX
SPECIFICATIONS

AND

SIGNIFICANT DATES

(Tentative)

1. September 15 - October 1, 1964 - Westinghouse supplier(s) receive Pu from Commission.
2. December 15, 1964 - Transfer Pu fuel rods to Westinghouse Reactor Evaluation Center, Waltz Mill, Penna. for critical experiments. (License SNM-783).
3. January 15 - March 10, 1965 - Perform critical experiments and evaluate data. (License CX-6)
4. March 10, 1965 - Transfer Pu fuel rods to Cheswick, Pa. for fabrication into Pu assemblies. (license SNM-338)
5. May 25, 1965 - Transfer fuel assemblies to Saxton Reactor site. (License No. SNM-338)
6. June 1, 1965 - Shutdown of Saxton plant; preparation for 2nd Core loading. (License No. DPR-4).
7. July 1, 1967 - Remove Pu assemblies from reactor core. (License DPR-4)
8. November 1, 1967 - Ship some Pu fuel assemblies to Waltz Mill, Post-Irradiation Facility (License No. SNM-770)
9. December 15, 1967 - December, 1968 - Examine and analyze Pu fuel.
10. December, 1968 - Return all fuel to designated facility for reprocessing.



Westinghouse Electric Corporation

Power Systems

Box 355
Pittsburgh Pennsylvania 15230

October 24, 1972

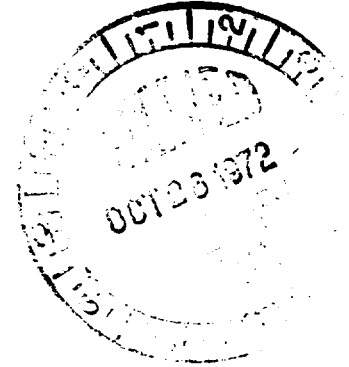

U. S. Atomic Energy Commission
Directorate of Licensing
Washington, D. C. 20545

Attention: Mr. Charles MacDonald, Chief
Transportation Branch

Gentlemen:

Subject: Application for Amendment of License SNM-338,
Docket 70-337, to Authorize Use of NFD Shipping
Packages

The Westinghouse Electric Corporation hereby requests that License SNM-338, Docket 70-337, be revised to delete Condition No. 6 from Amendment 71-42 of this license.

Condition No. 6 currently specifies a maximum external dose rate at 3 feet from the surface of the package. The deletion of this restriction would have no undue effect on the public health and safety because the regulations of the USDOT (Part 173 of Title 49, CFR) impose comparable, thoroughly adequate restrictions on the allowable external dose rates. These USDOT dose rates are adapted to the particular circumstances associated with the transport of the package.

Also, on the subject of NFD shipping packages. Westinghouse wishes to withdraw its request, dated June 6, 1972, for an amendment dealing with our BB 250-2 package. We will take no further action on that transmittal.

Please send the license amendment to me at the above address.

If you have any questions, please call me on (412) 373-4652.

Very truly yours,

Karl R. Schendel
Karl R. Schendel
License Administrator

CP 283

KRS:jh

ITEM # 402

5843



Westinghouse Electric Corporation

Power Systems

Box 355
Pittsburgh Pennsylvania 15230

October 23, 1972

U. S. Atomic Energy Commission
Directorate of Licensing
Washington, D. C. 20545

Attn: Mr. R. B. Chitwood, Chief
Fuel Fabrication & Reprocessing Branch

Gentlemen:

Subject: Application for Authorization to Import SNM;
Reference Docket 70-337

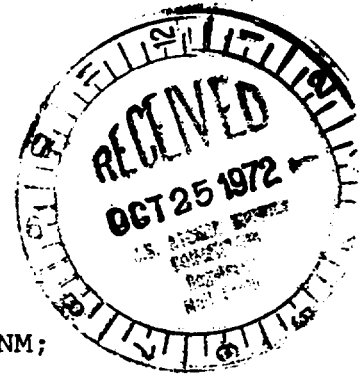

The Westinghouse Electric Corporation hereby requests authorization to import from Canada up to 175 grams of uranium-235 contained in up to six (6) kilograms of total uranium having a nominal enrichment of 3.0 w/o. The material will be uranium oxides as powder.

The SNM is Westinghouse-owned material that was sent to Canada. The material will be reprocessed, as necessary, and then absorbed into Westinghouse's operations.

The shipment will be received through Buffalo, New York. The bulk of the material will be packaged in Model LA-36 shipping packages that have been licensed by the USAEC on License SNM-338, Docket 70-337 and have been approved for use under the general license authorized by 10CFR71.9. The packages have received USDOT Special Permit No. 5442. Trace quantities of SNM may be present as surface contamination on equipment and/or machinery that had been sent to Canada and is being returned without being unpackaged (or even opened) in Canada.

Westinghouse requests that the import authorization be issued by December 15, 1972 and remain valid for ninety days. Please send the authorization to me at the above address.

If you have any questions, please write to me at the above address or telephone me on (412) 373-4652.

Very truly yours,

Karl R. Schendel
Karl R. Schendel
License Administrator

*C/MO/A
284*

ITEM # 403

KRS:jh

I



Westinghouse Electric Corporation

Power Systems

Box 355
Pittsburgh Pennsylvania 15230

August 11



U. S. Atomic Energy Commission
Directorate of Licensing
Washington, D. C. 20545

Attention: Mr. Richard B. Chitwood, Chief
Fuel Fabrication & Reprocessing Branch

Gentlemen:

Subject: Renewal of License SNM-338, Docket 70-337

REGULATORY OPERATIONS

The Westinghouse Electric Corporation hereby requests that License SNM-338, Docket 70-337, be extended until September 30, 1974 in accordance with the following provisions:

1. Existing license conditions will remain unchanged through September 25, 1972.
2. After September 25, 1972, the total authorized quantity of SNM will be up to 330 kilograms ²³⁵U as contained in uranium at enrichments equal to or less than 5 w/o.
3. Up to 5 kilograms of the SNM possessed after the September 25, 1972, date will be possessed and transferred as required incidental to the termination of manufacturing activities involving the uses of radioactive materials at the NFD Manufacturing Facility at Westinghouse Cheswick Site.

Efforts will be made to dispose of or decontaminate the entire facility to below the limits described in "Guidelines for the Decontamination of Facilities and Equipment Prior to Release for Unrestricted Use or Termination of Licenses for Byproduct, Source or Special Nuclear Materials" dated April 22, 1970.

4520

ITEM # 404

285
9/4/74
(H)

3. (continued)

Upon completion of cleanup and decontamination activities, USAEC representatives will be invited to inspect the areas. Following USAEC approval, the facility will be released for non-radioactive manufacturing activities.

4. The remaining quantity of up to 325 kilograms of the SNM possessed after the September 25, 1972, date will be possessed, stored only, and finally transferred to a customer. The SNM will be in the form of sintered UO_2 pellets (the uranium enrichment will be nominally < 3.25 w/o) encapsulated as fuel rods that have been fabricated into finished fuel assemblies.

The fuel assemblies will be loaded and sealed in Westinghouse Model RCC type shipping packages. The packages will be sealed with a tamper indicating seal and will be pressurized to a slight positive pressure using dry compressed nitrogen. A total of thirty (30) fuel assemblies will be stored.

The shipping packages will be stored outdoors in an existing oblong fenced area that lies adjacent to the driveway leading to the PFDL building (Bldg. 8), between it and the former ASTRO building (Bldg. 6). See the attached Cheswick Site Layout. The packages will be inspected on a weekly basis to assure the continued integrity of the seals; the continued presence of the internal positive pressure (containers that drift below a specified level will be repressurized, as necessary); and the continued general acceptability of the packages. Our experience with the specified shipping packages indicates that using them for outdoor storage for an extended period of time, considering the surveillance measures to be provided, is not unreasonable and would present no undue hazard to the health and safety of the public.

As can be seen on the attached Cheswick Site Layout, the chosen storage area is surrounded by an 8' security fence that is within the site perimeter security fence. The packages and even the individual welded fuel assemblies are too massive to be moved without the use of a mechanical lifting device. The only access road for such equipment back into the general vicinity of the storage area passes directly

4. (continued)

in front of the guard station, which will be continuously manned. During periods other than normal working hours, the area will be subject to visual checks by a member of the security force in the course of patrolling back to the PFDL building. Thus the safeguards provisions relating to this material are more than ample.

5. Westinghouse requests that the designated storage area be exempted from the criticality monitoring requirements of Section 70.24 of 10CFR Part 70. The only SNM present will be contained in shipping packages approved for loading and delivery to a carrier by Amendments 71-37 and 71-38 to this license (SNM-338, Docket 70-337). These amendments assign a transport index of 1.5 to each package when part of a Fissile Class II shipment. Since the designated 30 fuel assemblies will involve only 15 packages, the total transport index in the area will be less than half of an allowable vehicle load. There is no credible means by which the storage array could be accidentally converted into an arrangement more reactive than that considered in the transport accident analysis. Therefore, the nuclear criticality safety of the stored SNM is assured.

This application is intended to supersede in its entirety our request of May 25, 1972. Please take no further action on that application.

Please send the amended license to me at the above address.

If you have any questions, please write to me at the above address or telephone me on (412) 373-4652.

Very truly yours,



Karl R. Schendel
License Administrator

KRS:jh

Attachment

7 copies transmitted

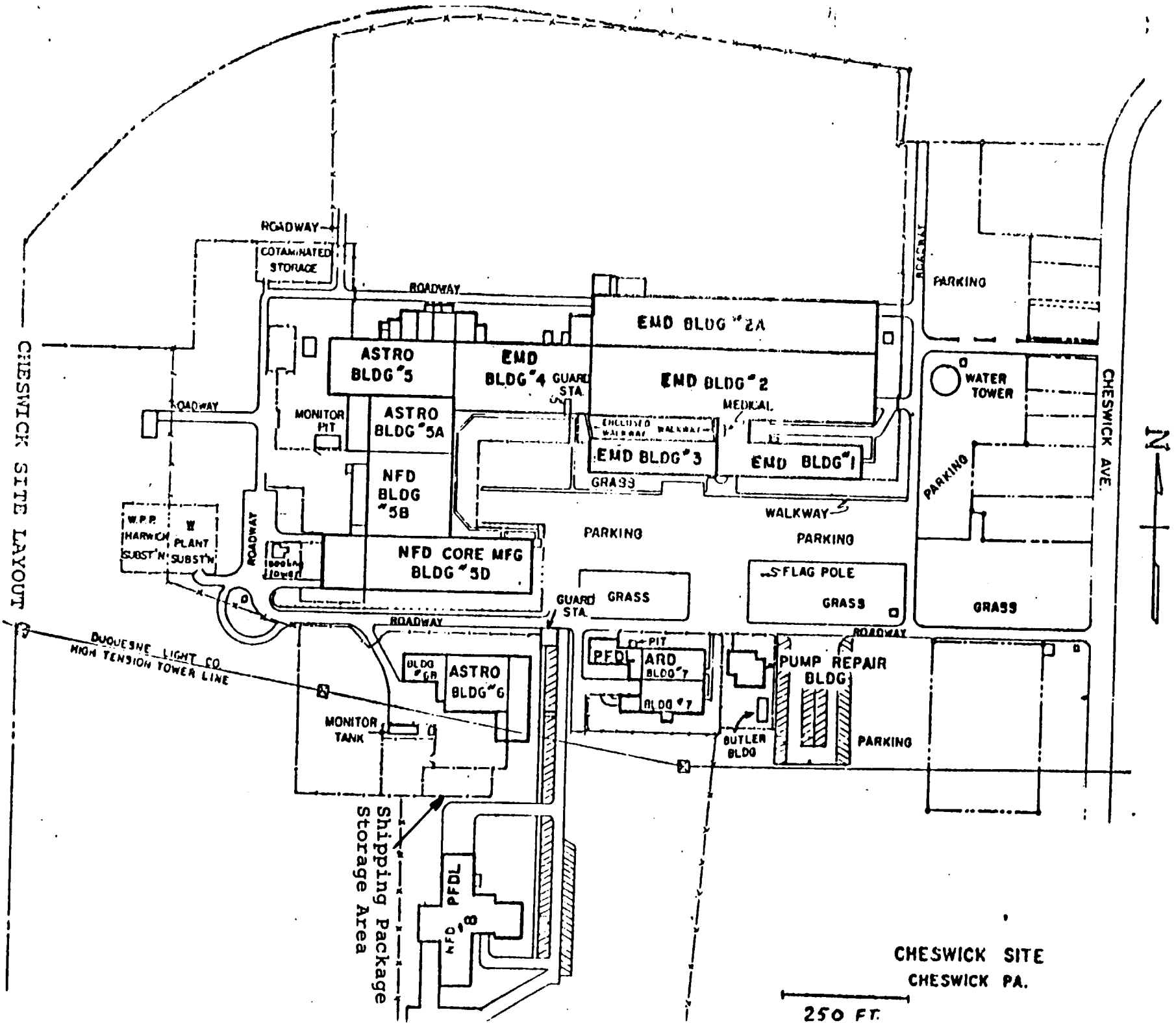

CHESWICK SITE LAYOUT



CHESWICK SITE
CHESWICK PA.

250 FT.

U.S. ATOMIC ENERGY COMMISSION
DIRECTORATE OF REGULATORY OPERATIONS
REGION I

RO Inspection Report No: 70-337/74-01
70-1143/74-03

Docket No: 70-337
70-1143

Licensee: Westinghouse Electric Corporation
NFD Plutonium Fuel Development Laboratory,
ARD Plutonium Laboratories, and Uranium Fabrica-
tion Facility

License No: SNM-338 ✓
SNM-1120

Priority: I

Category: 1(A)

Location: Cheswick, Pennsylvania

Type of Licensee: Fuel Fabrication

Type of Inspection: Unannounced - Routine

Dates of Inspection: June 26-28, 1974

Dates of Previous Inspection: October 31, November 1, 5 and 6, 1973
December 11-13, 1973

Reporting Inspector: *Philip C. Jerman*
Phillip C. Jerman, Radiation Specialist

6/18/74
Date

Accompanying Inspectors: NONE

Date

Date

Date

Date

Other Accompanying Personnel: NONE

286
9/10/75
Date

Reviewed By: *P. J. Knapp*
P. J. Knapp, Senior, Facilities Radiological
Protection Branch

ITEM # 405

7/10/74
Date

(8)

SUMMARY OF FINDINGS

Enforcement Action

A. Violations

Failure to bioassay individuals who work with uranium at intervals of 90 days or less. (Details, Section 6)

B. Safety Items

None

Licensee Action on Previously Identified Enforcement Items

Not Applicable

Unusual Occurrences

None

Other Significant Findings

A. Current Findings

None

B. Status of Previously Reported Unresolved Items

Not Applicable

Management Interview

At the conclusion of the inspection, a meeting was held with management. Those present were:

Westinghouse

H. Kunkle, Personnel Manager
W. E. Piros, Manager, Health, Safety and Services
P. J. Koppel, Manager, Plutonium Fuel Development Laboratory
W. R. Jacoby, Manager, Fuel Element Technology, Advanced Reactor
Development
C. W. Bickerstaff, Supervisor, Industrial Hygiene

AEC

P. C. Jerman

The inspector informed those present of the scope of the inspection. He stated that it appeared that the buildings and areas in which activities under License No. SNM-338 were conducted now met the Directorate of Licensing guidelines for decommissioning. He described the one violation observed.

DETAILS

1. Persons Contacted

W. E. Piros, Manager, Health, Safety and Services
C. W. Bickerstaff, Supervisor, Industrial Hygiene
R. Lange, Engineer, Plutonium Fuels Development Laboratory
J. Strand, Project Engineer, Equipment Development Laboratory
J. Scibilia, Technician, Industrial Hygiene
H. Andree, Technician, Industrial Hygiene
W. McDonald, Technician, Industrial Hygiene

2. Production Activities

A licensee representative stated that two plutonium nitrate shipments had been received at the Plutonium Fuel Development Laboratory (PFDL), since the first of the year. Each shipment was converted to plutonium oxide. Plutonium oxide was blended with uranium oxide (natural or depleted), pelletized and loaded into fuel rods. No operations involving plutonium were performed in the Advanced Reactor Development (ARD) facility in Building 7. Operations in Building 7 involve natural or depleted uranium oxide in work performed by Equipment Development Laboratory (EDL) personnel.

3. External Exposure

- a. The inspector reviewed external exposure records for calendar year 1973 and for 1974 through April. Regarding Form AEC-5 the inspector noted that the whole body exposure recorded for one employee totaled 3360 mrems for the third quarter of 1973. This total was based on reports received from power reactor customers to whom the employee was assigned. One customer reported a whole body exposure totaling 990 mrems for June and July, 1973. The other customer reported 2370 mrems for the period from July 25 to September 30, 1973. Through further contacts the inspector determined that the employee received 750 mrems during June, 1973 and 240 mrems during July, 1973. Thus the third quarter exposure reported by customers was 2610 mrems. The badges issued to this employee by the licensee totaled 1120 mrems for this period. A licensee representative could not explain the difference in the results of its badges and the customers badges issued to the individual.

- b. The records showed that no other employee received a whole body dose exceeding three rems per quarter. Neutron exposure is monitored by NTA film. The records showed only one positive monthly whole body exposure to neutrons and this was 140 mrem. Hand dose is monitored by TLD. The maximum quarterly hand exposure received by any employee was 1.9 rems during calendar year 1973, and 2.95 rems during the first quarter of 1974.

4. Inplant Air Monitoring

a. Plutonium Fuel Development Laboratory

- (1) The records of air sample results for the period from December 10, 1973, to the present were reviewed by the inspector. The records showed that about 40 general air samplers and 5 continuous air monitors, located in areas designed to produce useful information, were used for air monitoring. A licensee representative stated that any air sample result which showed greater than 1×10^{-12} μCi Pu alpha was investigated and the results of the investigation were documented by the Industrial Hygiene group. The inspector noted that 16 air samples exceeding this concentration were investigated during the period covered by the records under review. The licensee's investigation level is 50 percent of the MPC for soluble ^{239}Pu (2×10^{-12} $\mu\text{Ci}/\text{ml}$). The records revealed no case where it was possible for an individual to be exposed to more than 40 MPC hours.
- (2) The inspector noted in reviewing the records that six of the sixteen investigations conducted were concerned with the air lock of Glove Box 403 which contains a blend of plutonium-uranium oxide. The high concentrations were observed during the two month period from April to June, 1974. A licensee representative stated that the cause of the airborne activity was malfunction of the ventilation system. The air lock atmosphere was negative with respect to the glove box and to the room atmosphere, and use of the air lock brought contamination out into the room. The maximum concentration in air measured by the air sampler in the vicinity was 9.67×10^{-12} μCi ^{239}Pu alpha/ml over an eight hour period. Considering that the Pu handled is insoluble, the maximum possible exposure was 2 MPC hours.

b. Advanced Reactor Development Operation, Building 7

The inspector examined the records of inplant air sampling for the period from December 10, 1973 to the present. It was noted that there were 14 general air samplers and one continuous air monitor. Since the facilities have not been used for processing SNM since August, 1973, the filter papers were changed weekly and counted. No air sample result exceeded 1×10^{-12} $\mu\text{Ci } ^{239}\text{Pu}$ alpha (MPC = 2×10^{-12} μCi for soluble $^{239}\text{Pu}/\text{ml}$, 4×10^{-11} μCi for insoluble $^{239}\text{Pu}/\text{ml}$).

c. Equipment Development Lab, Building 7

- (1) The records of inplant air sampling were reviewed for the period from December 10, 1973 to the present. It was noted that there were 10 general air samplers. Filter papers were changed weekly and counted. The material handled in the facilities is natural or depleted uranium oxide for which the MPC is 6×10^{-11} $\mu\text{Ci}/\text{ml}$. The maximum air sample result was 4.4×10^{-10} $\mu\text{Ci U alpha}/\text{ml}$. The 40 hour MPC did not exceed this value.
- (2) The inspector observed that the general air sampler monitoring the press had been removed. A licensee representative stated it had been removed during modification of the press which was in progress. The inspector observed loose powder on the equipment. The licensee representative stated the air sampler would be reinstalled immediately.

d. Breathing Zone Air Sampling

The inspector reviewed the records of the results of personal (lapel type) air samplers used. The inspector noted that personal air samplers were used on nine occasions in the Plutonium Fuel Development Lab. The maximum exposure recorded by a breathing zone air sampler was 3.2 MPC hours.

5. Stack Air Monitoring

The stack air sample records for the period from December 10, 1973 to the present were examined. The inspector noted that filter papers for the eleven stack samplers at PFDL were changed and counted daily and those for the three exhaust stacks in Building 7 were changed and counted weekly. The maximum concentration for any stack releasing plutonium was 2.25×10^{-14} $\mu\text{Ci Pu alpha}/\text{ml}$ (MPC = 6×10^{-14} soluble $^{239}\text{Pu}/\text{ml}$) and for any stack releasing uranium was 4.55×10^{-13} $\mu\text{Ci alpha per ml}$ (MPC = 2×10^{-12} $\mu\text{Ci U alpha}/\text{ml}$).

6. Bioassay

- a. The inspector reviewed the records of results of bioassay for urine samples collected by employees since November, 1973. License Condition 14 requires that employees who work with plutonium and uranium have urine samples analyzed quarterly. It appeared that employees who work with plutonium submitted urine samples at least quarterly. The maximum ^{239}Pu alpha concentration in any sample submitted was $0.009 \pm .04$ dpm which is consistent with a maximum possible system burden of about one nCi ^{239}Pu . The maximum permissible body burden is 40 nCi ^{239}Pu .
- b. A licensee representative stated that about 10 employees work with uranium. The records showed that only two urine samples were submitted by employees since November, 1973. Both samples showed 0.0 ± 0.6 dpm U alpha.

7. Lung Counting

A licensee representative stated that no lung counts had been performed for employees since July 24-26, 1973.

8. Liquid Waste

- a. The inspector reviewed the records of concentrations of ^{239}Pu and U discharged in liquid waste to the sewer. The maximum concentration of ^{239}Pu in waste water discharged was 2.46×10^{-6} $\mu\text{Ci } ^{239}\text{Pu}$ alpha/ml with the exception of a tank of waste which had to be diluted before discharge. The concentration in the tank, which received washings for decontaminating an employee's hand, was 1.05×10^{-4} $\mu\text{Ci } ^{239}\text{Pu}$ alpha/ml. The average permissible concentration in waste discharge to the sewer is 5×10^{-6} $\mu\text{Ci Pu}$ and alpha/ml. The tank was diluted 21:1 in batches. The maximum concentration in any batch discharged to the sewer was 4.55×10^{-6} $\mu\text{Ci } ^{239}\text{Pu/ml}$. No credit was taken for dilution by the total plant sewer discharge.
- b. The average concentration of U in waste discharged to sewer was below that permissible (2×10^{-5} $\mu\text{Ci U}$ alpha/ml).

9. Environmental Monitoring

A licensee representative stated that installation of equipment for environmental sampling was started in April, 1974. Four of six planned air samplers were installed on plant property and are in service. Ten liquid fallout collectors were also placed on plant property and are in service. Water samples are taken monthly from the Allegheny River. All samples are analyzed for gross alpha and gross beta.

10. License No. SNM-338

Ref. - RO Inspection Report No. 70-337/73-02

The inspector surveyed the facility in which activities under License No. SNM-338 were conducted. The instruments used were an Eberline Model PRM-5-3 Pulse Rate Meter with Model SPA-3 Scintillation Probe Assembly and an Eberline Model E-120 Survey Meter with end window GM probe which had been calibrated with uranium. All spots identified in the referenced Inspection Report were found to be reading less than 0.05 mR/hr at 1 cm. A licensee representative stated that all floor drain lines were filled with concrete.

3402

ITEM #

HMC

LUG-2 REQ'D-METHOD OF ATTACHMENT OPTIONAL

10-3/16 MAX.

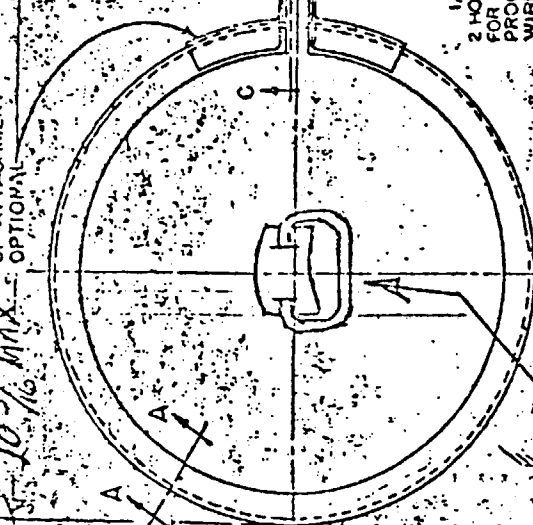

LOCKING RING

VIEW "C-C" (TYP)

2 HOLES EACH FOR TAMPERS PROOF SEAL

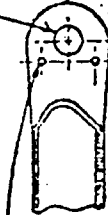

NOTE: FURNISH WITH CADMIUM FLATED HEX HD. 1/4-20NC-2A X 1-1/2 LG. BOLT THD LGTH. 1-1/2 IN.; SCREWDRIVER SLOT 1/8 X 3/32 DR WITH PNT. OR 1/4-20NC-2A X 1-1/2 LG. RD. 10. BOLT. THD LGTH. 1-1/2 IN.; SCREWDRIVER SLOT 1/8 X 3/32 DR WITH PNT. SEE FEDERAL SPECIFICATION QQ-P-416A.

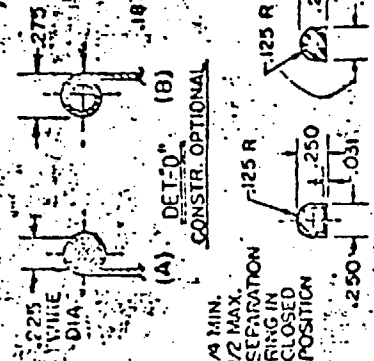

1/4 MIN. SEPARATION RING IN CLOSED POSITION

GASKET ALT. GASKET

SEC "A-A"

SEC "B-B"

FED. SUP. CLASS 8110

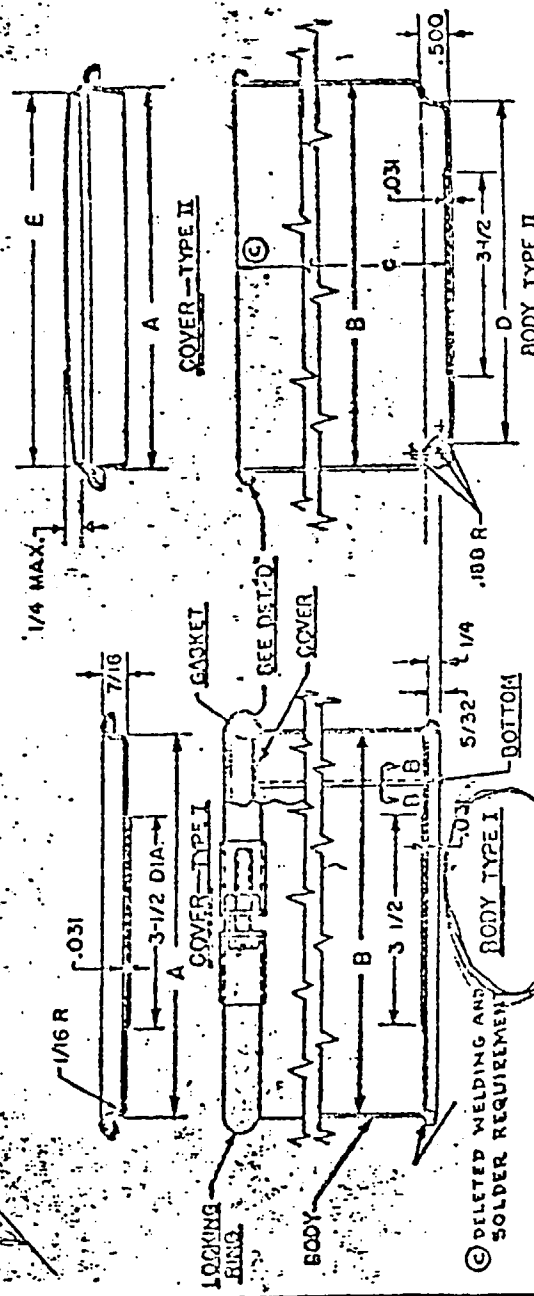

LOCKING RING

BODY

COVER-TYPE I

COVER-TYPE II

DELETED WELDING AND SOLDER REQUIREMENT

SEE DET'D COVER

ROD

BOTTOM

BODY TYPE II

| DRUM ASSY (TYPE I COVER) | DRUM ASSY (TYPE II COVER) | BOOT TYPE I | BOOT TYPE II | COVER TYPE I | COVER TYPE II | LOCKING RING | GASKET | D |
|--------------------------|---------------------------|-------------|--------------|--------------|---------------|--------------|------------|--------|
| MS24347-1 | MS24347-11 | MS24347-21 | MS24347-21 | MS24347-41 | MS24347-51 | MS24347-61 | MS24347-81 | 4-1/4 |
| MS24347-2 | MS24347-12 | MS24347-22 | MS24347-22 | MS24347-42 | MS24347-52 | MS24347-62 | MS24347-82 | 5-3/4 |
| MS24347-3 | MS24347-13 | MS24347-23 | MS24347-23 | MS24347-43 | MS24347-53 | MS24347-63 | MS24347-83 | 7-3/4 |
| MS24347-4 | MS24347-14 | MS24347-24 | MS24347-24 | MS24347-44 | MS24347-54 | MS24347-64 | MS24347-84 | 15 3/4 |
| MS24347-5 | MS24347-15 | MS24347-25 | MS24347-25 | MS24347-45 | MS24347-55 | MS24347-65 | MS24347-85 | |
| MS24347-6 | MS24347-16 | MS24347-26 | MS24347-26 | MS24347-46 | MS24347-56 | MS24347-66 | MS24347-86 | |
| MS24347-7 | MS24347-17 | MS24347-27 | MS24347-27 | MS24347-47 | MS24347-57 | MS24347-67 | MS24347-87 | |
| MS24347-8 | MS24347-18 | MS24347-28 | MS24347-28 | MS24347-48 | MS24347-58 | MS24347-68 | MS24347-88 | |

NOTE: SIZES WILL CONFORM TO THOSE INDICATED IN PARAGRAPH 1.2.1 OF MIL-D-6055. TYPE OF CONSTRUCTION: BODY MAY BE FORMED AS SHOWN IN TYPE I, OR DIAPHY WITHOUT SEAMS AS SHOWN IN TYPE II. MATERIAL: STEEL, SPECIFICATION QQ-S-690. (BODY-BOTTOM AND COVER, FOR 5" DIA DRUMS GAGE NO 24; 6-1/2 AND 8-1/2" DIA DRUMS GAGE NO 24. LOCKING RING GAGE NO 20. LUGS GAGE NO 14.) ALUMINUM ALLOW AS NOTED IN PARAGRAPH 1.1.1 OF MIL-D-6055. GASKETS SYNTHETIC RUBBER WEATHER RESISTANT, SHORE HARDNESS 60. SEE PARAGRAPH 3.1.3 OF MIL-D-6055. *PARKING: SEE PROCUREMENT SPECIFICATION

1/4 PART IN. ADD D IN PLACE OF THE DASH IN THE PART NUMBER FOR ALUMINUM ALLOW, I.E., MS24347-81. DRUM AND COVER WILL BE RECESSED AS NOTED IN PARAGRAPH 3.8.1 OF MIL-D-6055. DIMENSIONS IN INCHES UNLESS OTHERWISE SPECIFIED. TOLERANCES: DECIMALS .003 FRACTIONS 1/32. NOTE: *FOR DESIGN FEATURE PURPOSES, THIS STANDARD TAKES PRECEDENCE OVER PROCUREMENT DOCUMENTS DATED PRIOR TO THIS DATE.

1/A AIR FORCE-MOA Other Cont

ARMY - GL NAVY - WEPS

TITLE

DRUMS, METAL-SHIPING & STORAGE

MILITARY STANDARD

MS 24347

PRELIMINARY SPECIFICATION MIL-D-6055

SUPERSEDES

MS 24347 REV. D

SHEET 1 OF 1

Controlled by: Army-CL, Navy-Weps, Air Force-MOA, Preparing Activity: Air Force-MOA, Reviewer: CL, MO, KU, Weps, SGA, MOA, OCA, OCA, SGA, WRA (Reviewer/User Information is current as of the date of this document. For future coordination of change to this document, draft circulation should be based on the information in the current DDISS), Project No. 8110-0078

APPROVED 1 FEB 56 (A) 1 MAY 56 (B) 19 APRIL 62 (C) 1 JUNE 64 (D) REVISED

DWG.
ED 323133B
SK

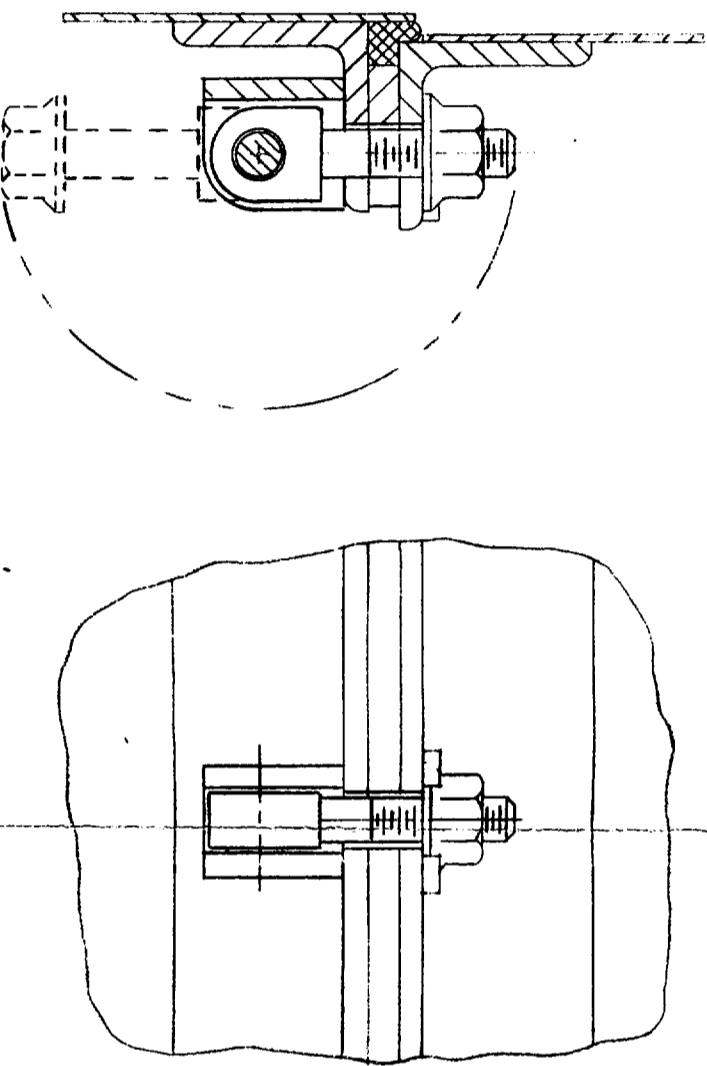

FIGURE 3

SO SCF 29
D 1

IT CHANGE

WHITE BACKGROUND OF PRINTS
INDICATES FULLY APPROVED
DRAWING.
GREEN BACKGROUND OF PRINTS
INDICATES PRELIMINARY DRAWING,
UNAPPROVED DRAWING, OR DRAWING
NOT AUTHORIZED FOR CONSTRUCTION
USE.

NEXT ASSY.
REF. DWG.

| | | |
|-------------|---------------------|---------|
| DFTM. | <i>P. Hoffman</i> | 6-24 |
| CHKR. | | 6-24 |
| DES. ENG. | <i>J. W. Keller</i> | 8-6 |
| MFG. ENG. | <i>W. J. Quetta</i> | 8-9-65 |
| MTLS. ENG. | | |
| APP. | | |
| APP. | | |
| DFTG. SUPV. | <i>[Signature]</i> | 6/16/65 |

WESTINGHOUSE ELECTRIC CORPORATION
ATOMIC POWER DIV., PITTSBURGH, PA., U.S.A.
TITLE:
SCHEMATIC OF CONTAINER
ASS'Y CLOSURE CLAMP
FITTING
SCALE
DIMENSIONS IN INCHES
DO NOT SCALE
ED 323133B
SUB 1

**OVERSIZED DRAWING
PAGES EXIST AT THIS
POINT IN THE
DOCUMENT**

**WHICH ARE LISTED UNDER
THE CONTENTS OF THIS
PACKAGE**

NOTE: Due to these page's large file size, it may be more convenient to copy the file to a local drive and use the Imaging (Wang) viewer, which can be accessed from the Programs/Accessories menu.